

VOLUME 24

PARTS 1 & 2

DECEMBER 1938

THE JOURNAL OF EGYPTIAN ARCHAEOLOGY

PUBLISHED BY
THE EGYPT EXPLORATION SOCIETY

Reprinted photographically at the University Press, Oxford 1973

THE JOURNAL
OF
EGYPTIAN ARCHAEOLOGY

ALL RIGHTS RESERVED

THE JOURNAL
OF
EGYPTIAN ARCHAEOLOGY

VOLUME 24

PUBLISHED BY
THE EGYPT EXPLORATION SOCIETY
2 HINDE STREET, MANCHESTER SQUARE, W. 1
LONDON

1938

*Printed in Great Britain
at the University Press, Oxford
by Vivian Ridler
Printer to the University*

CONTENTS

	PAGE
THE BIOGRAPHICAL INSCRIPTIONS OF NEKHEBU IN BOSTON AND CAIRO	Dows Dunham ... 1
A WRITING-PALETTE OF THE CHIEF STEWARD AMENHOTPE AND SOME NOTES ON ITS OWNER	William C. Hayes 9
SOME REPRESENTATIONS OF TOMBS FROM THE THEBAN NECROPOLIS	Nina M. Davies ... 25
THE BREMNER-RHIND PAPYRUS—IV	R. O. Faulkner ... 41
FURTHER NOTES ON SOME EGYPTIAN FIGURES OF CATS	N. Langton ... 54
THOUGHTS ON THREE RECENT ARTICLES	G. A. Wainwright 59
THE ELECTION OF THE METROPOLITAN MAGISTRATES IN EGYPT	A. H. M. Jones ... 65
NOTES ON UNIVERSITY OF MICHIGAN DEMOTIC PAPYRI FROM PHILADELPHIA	Charles F. Nims 73
THE MANSION OF LIFE AND THE MASTER OF THE KING'S LARGESS	Alan H. Gardiner 83
BIBLIOGRAPHY: GRAECO-ROMAN EGYPT: PAPYROLOGY (1937) 92
BIBLIOGRAPHY: CHRISTIAN EGYPT (1937)	De Lacy O'Leary 118
THE SO-CALLED OMPHALOS OF NAPATA	Georg Steindorff 147
PRELIMINARY REPORT ON THE EXCAVATIONS AT SESEBI (SUDLA) AND 'AMĀRAH WEST, ANGLO-EGYPTIAN SUDAN, 1937-8	H. W. Fairman ... 151
THE HOUSE OF LIFE	Alan H. Gardiner 157
THE PRESENT POSITION OF THE METROLOGY OF EGYPTIAN WEIGHTS	Flinders Petrie ... 180
THREE OLD-KINGDOM TRAVELLERS TO BYBLOS AND PWENET	Percy E. Newberry 182
PYGMIES AND DWARFS IN ANCIENT EGYPT	Warren R. Dawson 185
THE STELA OF THE SCULPTOR SIRĒC AT OXFORD	A. N. Dakin ... 190
POISONS IN ANCIENT EGYPT	A. Lucas ... 198
THE CURRENCY OF EGYPT UNDER THE PTOLEMIES	J. G. Milne ... 200
SIR ROBERT MOND, LL.D., F.R.S., 1867-1938	Percy E. Newberry 208
ALAN WYNN SHORTER, 1905-38	A. M. Blackman ... 211
BIBLIOGRAPHY: PHARAONIC EGYPT (1937) 213
BRIEF COMMUNICATIONS 124, 242
NOTES AND NEWS 130, 247
CORRESPONDENCE 136
REVIEWS AND NOTICES OF RECENT PUBLICATIONS 137, 250

LIST OF ABBREVIATIONS USED IN REFERENCES TO PERIODICALS, ETC.	258
LIST OF PLATES	263
LIST OF ILLUSTRATIONS IN THE TEXT	265
LIST OF REVIEWS AND NOTICES OF PUBLICATIONS	266
INDEXES			
General	267
Egyptian	271
Coptic and Greek	273

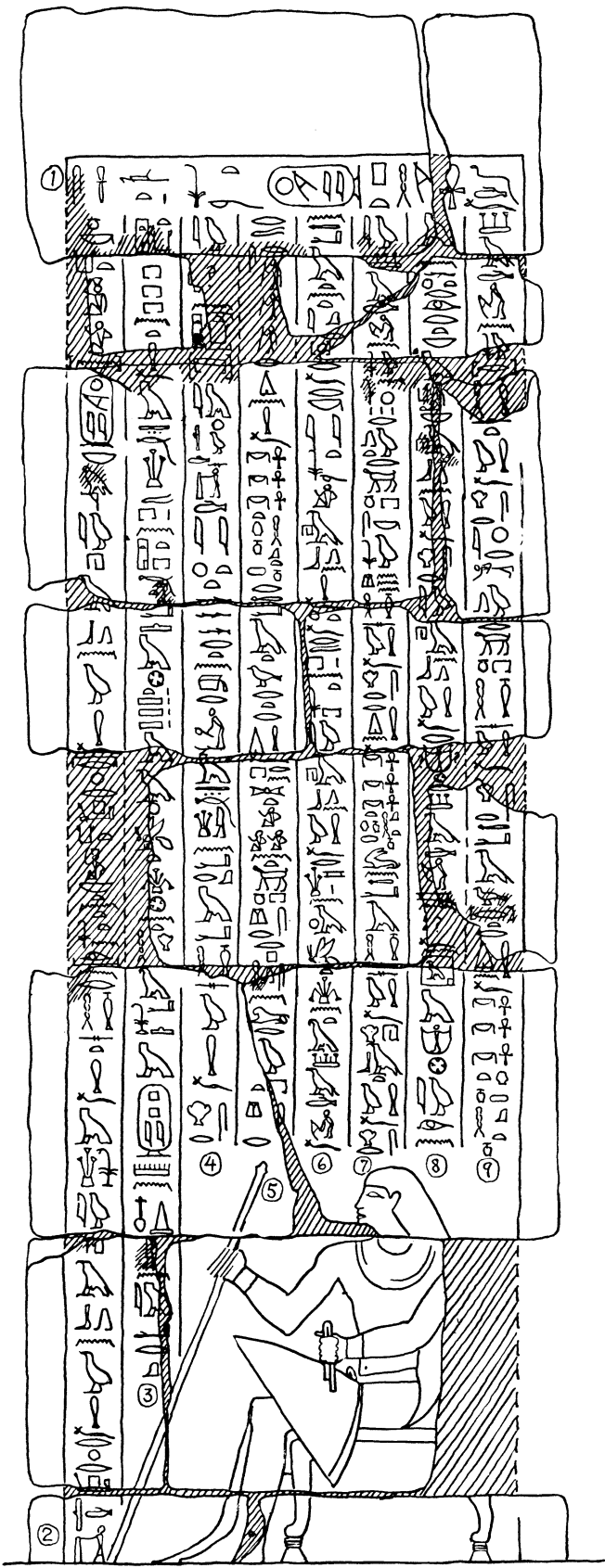

BIOGRAPHICAL INSCRIPTION OF NEKHEBU AT BOSTON

dug it [so that] His Majesty praised me for it. When I went to the Residence His Majesty praised me for it very greatly, and His Majesty gave me gold-amulets (?), bread, and beer.

CAIRO TEXT

After *Urk.*, I, pp. 215 ff.

A small, somewhat weathered block belonging to the Cairo inscription was recently found in the store-rooms of the Boston Museum, whither it had evidently been shipped by mistake together with the stones of the Boston inscription. It has since been returned to the authorities in Cairo for insertion in its proper place. The block belongs in the lower part of columns 2, 3, and 4, and reads $\leftarrow\downarrow$:

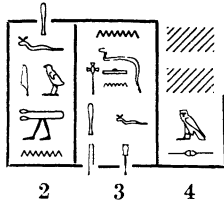

In the translation below the words appearing on this block are underlined.

Collation of Sethe's copy of the inscription, given in *Urk.*, I, 215 ff., with Gunn's copy made in 1931, when a wrongly-placed slab had been restored to its proper position, but before the fragment mentioned above had been received from Boston. The references are to the pages and lines of Sethe's edition, except numbers in thick type, which are those of the lines of the inscription.











P. 215. L. 9: **1** runs horizontally over **2-11**, which are vertical. L. 10: 4½ to 5 sq. lost at beginning of **2**. \curvearrowright in cartouche clear though damaged. L. 11: \square of *hrp* not lost. L. 13: stick of det. *hrp* is straight and vertical. L. 15: \curvearrowright clear. After *kd* 1 sq. lost. \curvearrowright clear. Ll. 15-16: between \curvearrowright and end of **3** only ⅔ sq. lost. L. 16: 4½ to 5 sq. lost at beginning of **3**. Trace before \downarrow seems to be clearly tail of \curvearrowright .

P. 216. L. 1: G. has $\downarrow \curvearrowright \text{𐀀}$, *kd*. L. 2: G. has lower part of 𐀀 with ?, and no stroke after this. L. 4: \square not followed (as in L. 15) by 𐀀 , *sic*. L. 5: after *hm:f* possibly 1 sq. missing, possibly nothing. L. 6: $\downarrow \downarrow \downarrow$ followed by 1½ sq. now lost. L. 9: \curvearrowright , \curvearrowright now lost.

G. saw $\downarrow \text{𐀀} \text{𐀀}$; after this 5 sq. now lost before $\text{𐀀} \text{𐀀}$. L. 12: \odot of *lhr* now lost. L. 13: *nd-ti* without \curvearrowright *sic*. \diamond before *hkr* now lost. *Niwt* without \curvearrowright *sic*.

P. 217. L. 1: 𐀀 of *nd* now lost. L. 4: $\text{𐀀} \text{𐀀} \text{𐀀} \text{𐀀}$, agreeing (independently) with Reisner's copy. Ends of fingers turned *backwards*. L. 5: 𐀀 without tuft. $\text{𐀀} \text{𐀀} \text{𐀀}$ *sic*. L. 8: det. *špt* \triangle (= \curvearrowright ?), not accompanied by \downarrow . \cup now lost. L. 9: \circ now lost. \triangle , not \triangle . Narrow damaged strip beside *hbs*, but no trace of \curvearrowright ; perhaps nothing lost. Trace of 𐀀 , \curvearrowright of *hkr*, \cup , all now lost. L. 11: $\downarrow \downarrow \text{𐀀}$, without \curvearrowright . \curvearrowright clear though damaged. L. 13: beside (ed. Sethe under) $\text{𐀀} \text{𐀀}$ now only 𐀀 . Under first \cup is \curvearrowright . Under second \cup is \curvearrowright with Sethe. After this \circ clear. L. 14: after 𐀀 no \downarrow . \circ of *tr* now lost.

P. 218. L. 1: only ½ sq. lost before *t h[nkt]*, no trace of sign 𐀀 of *hnkt* now lost. \curvearrowright of 𐀀 not seen; copy has 𐀀 ? No room for *ds·tn*: $\text{𐀀} \text{𐀀} \text{𐀀} \text{𐀀}$. L. 2: 𐀀 , as 217, 16, not \curvearrowright . Det. *sb* 𐀀 . L. 3: trace of \triangle now lost. Next three signs disposed $\downarrow \downarrow \downarrow$. L. 5: 𐀀 *sic*. L. 7: \square of *pn* now lost. L. 8: 𐀀 *sic*. 𐀀 , as 217, 16, not \curvearrowright . $\downarrow \downarrow$ *sic*. 𐀀 . L. 10: det.

sb . Back of  visible, not legs. L. 11: *sic* . L. 12: . Det. *sb* . . L. 14:  *sic* . L. 15: between  and  1 sq. now lost.

P. 219. L. 2: object held in det. *sšn* narrow and tapering to top. L. 4: object held in det. *sšn* rectangular, as Sethe gives, but narrower. L. 6: *t* of first *nfrt* now lost.

Translation

(1) [The Sole Companion, King's Architect, Merptaḥ(ankhmeryrēc)];¹ he says: (2) [I am a workman of]¹ Mer[rēc], my lord.



His Majesty sent me to direct the work of his (pyramid)-monument² in Heliopolis, and I acted to the satisfaction of His Majesty. I passed 6 years there in directing the work. His Majesty praised me as often as I came to the Residence because of it; everything came about [through my agency]³ because of the vigilance that I exercised;⁴ (3) [his] there, in accordance with what I know myself.⁵

His Majesty had found me a common builder;⁶ and His Majesty conferred on me (the offices of) Inspector of Builders, (then) Overseer of Builders, and Superintendent of a Guild. And His Majesty conferred on me (the offices of) King's Architect and Builder, (then) Royal Architect and Builder under the King's Supervision (?). And His Majesty conferred on me (the offices of) Sole Companion, King's Architect and Builder in the Two Houses. His Majesty did all this because His Majesty favoured me so much.⁷

(4) I am beloved of my father, praised of my mother.⁸ I did [not] give them occasion⁹ to punish me until (i.e. up to the time when) they passed¹⁰ to their tomb of the necropolis; and I am one praised of his brothers. Now I was in the service of¹¹ my brother, the Overseer of Works *ms* I used to do the writing,¹² I used to carry his palette (?).¹³ When he was appointed Inspector of Builders, I used to carry his measuring-rod (?).¹⁴ (5) When he was appointed Overseer of Builders, I used to be his companion (?).¹⁵ When he was appointed King's Architect and Builder,

¹ Missing. Restored (with Sethe) after the Boston text.

² The pyramid-sign is determinative of *mnw*, not to be read.

³ Restoring with Sethe  , for which cf. *Urk.*, I, 108, 10.

⁴ Cf. *Urk.*, I, 127, 10; 129, 13.































⁵ *R rht-i ds-i*. For the construction see *Wb.*, II, 445, 5.

⁶ Cf. *Wb.*, I, 228, 21.

⁷ Perhaps nothing lost here; see Gunn's collation.

⁸ The construction with the first person (*tf-i*, *mut-i*) is very curious.

⁹ Lit., 'cause them'.

¹⁰ This word                               

I used to rule the city for him, and did everything in it excellently. When he was appointed Sole Companion, King's Architect and Builder in the Two Houses, I used to take charge of all his possessions for him, and the property was greater (or increased more?) in his house than (in) the house of any noble. When (6) he was appointed Overseer of Works, I used to represent¹ him in everything about which he spoke,² to his satisfaction concerning it. Moreover, I took charge of things for him in his estate for the period of 20 years. Never did I beat any man there so that he fell³ through my action.⁴ Never did I enslave any people there: as to all people there (7) with whom I used to negotiate⁵ there,⁶ it was I who used to pacify them.⁷ Never did I go to rest for the night there angry with any people. It was I who used to give⁷ clothing, bread, and beer to every naked man and hungry man there.

I am beloved of all men: never did I say anything evil to the king (or) to a high authority against any man. I am one praised by his father, his mother, and his masters in the necropolis (8) for making funerary-offerings for them and making their festival⁸ on the *W3g*-Feast, the Feast of Socharis, the First-of-the-Year-Feast, the Feast of Thoth, the Opening-of-the-Year-Feast, the first day of the month,⁹ the last day of the month, and on every good feast which is celebrated at every season of the year.

O *Ka*-servants of the honoured (dead): do ye¹⁰ desire¹¹ that the king shall favour you, and that ye shall be in honour¹² with your lords and fathers in the necropolis? (Then) ye shall make funerary-offerings (9) of bread and beer, as I have done for your fathers.¹³ Since ye will desire that I intercede for (?)¹⁴ you in the necropolis, (then) tell ye to your children, on the day when I shall have passed

¹ Lit. 'report'.

² *Mdw m* must surely mean 'to speak about' here, although *Wb.* knows only the meaning 'to speak against'; cf. perhaps *bw nb ddd n-k im*, 'every place about which you have been told (?)', *Urk.*, I, 296, 5.



³ Lit. 'so that a fall took place (?)'. The text has *hpr hr*; see the collation, p. 3.

⁴ Lit. 'under my fingers'; cf. *Wb.*, v, 565, 3.

⁵ *D3s*, old form of *d3is*, see *Wb.*, *sub voc.* The construction *unw-n-i d3s-i hnt-sn* is similar to that of *Pyr.*, § 759 c (especially the M-text), 760 b.

⁶ The adverb *im* seems to have been repeated unnecessarily.

⁷ For the construction of *ink wn-i shtp-i sn*, *ink wn-i di-i*, cf. *ink wn-i ir-i n-sn shr* 'it was I who used to direct them', *Urk.*, I, 102, 9. For examples of *wn-f sdm-f* (for which in Mid. Egn. see Gard., *Gr.*, § 474, 2) cf. *Urk.*, I, 44, 8; 194, 10, besides 59, 16 cited by Gardiner. ⁸ *M prt n-sn hrw, m irt hb-sn*.

⁹ For this word (often written with the sun between the horns) cf. Anthes, *Felseninschriften v. Hatnub*, Graffito 9 (Pl. 13), line 2, with pp. 23-4; Petrie, *Qurneh*, Pl. x, B 33, line 4; Berlin Pap. 10500 (unpublished); *El Bersheh*, II, 44, right, line 6 of vertical inscription; written  as here, on an unpublished fragment of Fifth-Dynasty papyrus in the Cairo Museum, and several times in the still unpublished Hekanakhte Papyri. It does not seem to occur in dates after the early Middle Kingdom, but is perhaps the original of the late word , which is apparently (cf. *Wb.*, I, 304, 12) a general word for 'feast'.

¹⁰ Rhetorical question, equivalent to protasis of conditional sentence; cf. the examples quoted Firth-Gunn, *Teti Pyramid Cemeteries*, 100, n. viii.

¹¹ Gardiner, *Some Aspects of the Egyptian Language*, from *Proc. Brit. Acad.* 23, p. 12 with p. 26, n. 19, points to  here and in 218, 16 as valuable evidence of the derivation of the *sdm-n-f* form from a passive participle+dative. This interpretation presumably involves past meaning in these two places, although with the verb *mri* a past tense has often to be translated as a present one (cf. Sethe, *Verbum*, II, § 761, 3); it is however also possible that *mry* was felt here as passive participle functioning as adjectival predicate, followed by the dative: 'Is that the king praise you etc. desirable to you?'

¹² Lit. 'that your state-of-honour shall be with'; so also in line 9 below.

¹³ 'As your fathers have done for me' (*mi irt-n n-i tfw-tn* instead of *mi irt-n-i n tfw-tn*) is grammatically equally possible; in this case Nekhebu will be addressing people of more than one generation after his death. On this passage see Clère in *Mél. Maspero*, I, 783.

¹⁴ Despite the quite different writing of the verb *sb*, it is difficult not to identify it with the verb of e.g. , *Urk.*, I, 122, 12 (cf. 261, 8; 223, 1 ?); for the idiom cf. Gardiner-Sethe, *Letters to the Dead*, 20, with references; *Wb.*, III, 430, 6.

B. MFA. No. 13.4348. Left jamb of a doorway with standing figure of Nekhebu, and one column of inscription ↘:

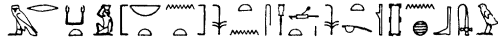

C. MFA. No. 13.4349. Right jamb of the same doorway, inscribed ↙:

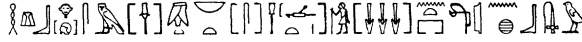

D. MFA. No. 13.4351. Block with relief head of Nekhebu, and four columns of inscription above (incomplete at top) ↙:

- (1) [Hieroglyphs]
- (2) [Hieroglyphs]
- (3) [Hieroglyphs]
- (4) [Hieroglyphs]

In front of Nekhebu's face, the incomplete title [Hieroglyphs].

On the wall adjoining the Boston text is a scene showing Nekhebu spearing fish from a canoe (MFA. No. 13.4332). In the canoe in front of him stands a smaller figure, also spearing fish, with an incomplete inscription reading 'His brother, the Lector,'. Behind Nekhebu in the same scene stands a small figure of his son, named [Hieroglyphs].

Again, on an isolated block showing part of a procession of sacrificial animals (13.4346), is the figure of a man inscribed 'His brother, the Lector, Merptahankhepepy'. It must remain uncertain whether either of these brothers (they may, of course, be one and the same) is to be identified with the one mentioned in the Cairo text, since his name is missing.

NOTE ON THE OFFICES AND CAREER OF NEKHEBU

The Cairo text yields interesting evidence on two matters connected with Nekhebu's professional career. In the first place he lists the offices to which he was appointed, presumably in the order of their acquisition. Secondly, in his account of his apprenticeship to his brother, he gives both the steps by which the latter rose in his profession, and the preliminary training which he himself underwent. These records not only give us an indication of the relative grades of the various professional offices, but also tend to show that they were not, at this time, acquired purely by inheritance, but were, in part at least, the rewards of training and experience.

The professional posts held by the two men appear to have been as follows, in order of progressive importance:

NEKHEBU	BROTHER
1. Common Builder	
2. Inspector of Builders	Inspector of Builders
3. Overseer of Builders	Overseer of Builders
4. Superintendent of a Guild	
5. King's Architect and Builder	King's Architect and Builder
6. Royal Architect and Builder under the King's Supervision	
7. King's Architect and Builder in the Two Houses	King's Architect and Builder in the Two Houses
8. Overseer of all Works of the King	Overseer of Works (perhaps a short form of title 8)

Whether the brother also held offices 4 and 6 does not appear. Nekhebu would naturally be very particular in recording all the steps in his advancement, but might well have given his brother's career somewhat more summary treatment.

Other offices and honours enjoyed by Nekhebu, as shown by the inscriptions from his tomb given above, were the following:

Overseer of Royal Commissions of the Pyramid Menneferpepy (perhaps acquired in connexion with the mission referred to in Boston text, line 3).

[Master of Secrets] of the Two *wbt*-Chambers.

Elder of the *snwt*-House.

Director of Every Kilt.

Door-keeper of (the god) *Dwrw*.

Favourite Sole Companion of His Lord.











Sole Companion. (As also the brother.)

First under the King.

Chief Lector.

Šm-Priest.

NOTE

Just before sending Mr. Dunham's contribution to press we received from M. Jean Sainte Fare Garnot an offprint of his interesting article *Une Graphie fautive du verbe sbi* —  in *Bull. Inst. fr.* 37, 63 ff. He deals with the words *sb*, written with a fish-sign, which occur in ll. 9, 10 (twice) of Nekhebu's Cairo inscription (see pp. 5, n. 14; 6, nn. 5, 7, above). M. Garnot regards all three examples as abnormal writings of the common verb . Mr. Dunham has taken this view (p. 5 above, n. 14) as regards the example in l. 9. (Another and even more abnormal writing of this word in the idiom *sb̄i hr̄* 'to intercede for (?)', 'to protect (?)' is perhaps—against *Rock Tombs of Meir*, IV, 25, n. 3—the  of *Urk.*, I, 223, 1 referred to p. 5, n. 14). The passages containing the two other examples of *sb*, where Mr. Dunham, following *Wb.*, suggests 'to be hostile', are rendered by M. Garnot (p. 70): 'N'entrez pas dans cette tombs, *avançant* . . . pour votre part (*n·tn*), alors que vous êtes impurs. Pour tout homme qui entrerait dans cette tombs *avançant* après ceci, je serai jugé avec lui par le Dieu grand' (italics ours). Here the identification with  seems to us less plausible than to M. Garnot, on grounds not only of the sense, which is poor, but of grammar (verb of motion in Old Perfective dependent on another verb of motion). The explanation (pp. 72 ff.) of the use of the fish-sign as due to the chance juxtaposition in l. 9 of the signs —  , reminding the 'scribe' of the verb —  , seems to us improbable. M. Garnot has perhaps overlooked the word  'kind of fish' *Wb.*, III, 432 (13), from which the sign might, at least in l. 9, have been borrowed. It seems further just possible that in the verb —  the fish may have the value *sb*; cf. the use of  with *id* (e.g., Ranke, *Personennamen*, 53-4) and *idn* (Gard., *Gr.*, p. 455). M. Garnot regards (p. 67) the  of ll. 4, 9 (twice) as a writing not of *šw̄* or *šd̄* (p. 4 above, n. 10), but perhaps of *šh̄* 'draw near', which seems specially difficult to reconcile with the context in line 4, where it is followed by *hr̄*. The article contains facsimiles and a number of useful observations which should be read in connexion with Mr. Dunham's contribution.—EDITOR.



1

Biographical Inscription of
Nekhebu at Boston.

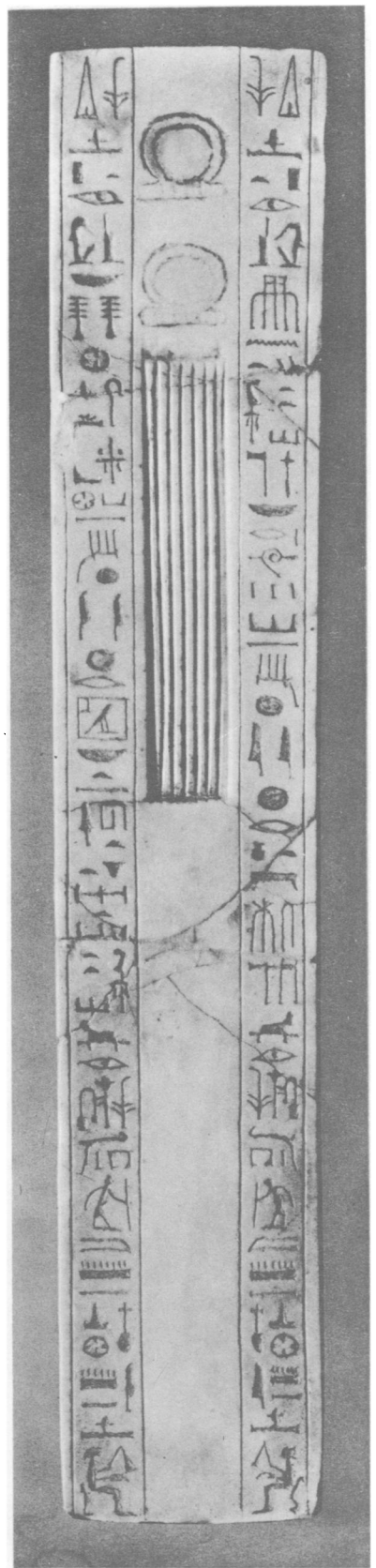

2

Writing-palette of the Chief
Steward Amenhotpe.

A WRITING-PALETTE OF THE CHIEF STEWARD AMENHOTPE AND SOME NOTES ON ITS OWNER

By WILLIAM C. HAYES

With Plate i (2)

THE Metropolitan Museum of Art in New York has recently acquired a scribe's palette which was once the property of an important Memphite official of the late Eighteenth Dynasty (Pl. i, 2).¹ As is often the case with this class of object, the palette is a funerary model, a 'dummy' reproduction in stone of a real pen-case.² Of milky white, almost grainless alabaster (calcite), the slab measures 44.7 cm. in length, 7.6 cm. (bottom) to 8.2 cm. (top) in width, with a mean thickness of 1.25 cm. The first dimension, as may have been noted, is almost exactly the short cubit of 6 palms,³ the width being slightly over 1 palm. The back and edges of the slab are quite plain, but on the front surface are carved the salient features of the average writing-palette: the open upper end of the pen-slot, with the tops of the reed pens appearing in it, and above this the two circular ink-wells, here merely suggested by two \bigcirc signs incised in outline on the surface of the stone. Down each side of the front of the palette runs a column of incised hieroglyphic inscription (width 2 cm.):

Left. *An offering which the king gives (to) Osiris, Lord of Busiris, Ruler of Abydos, on behalf of the one in honour with Hathor, Lady of the Sycamore, Mistress of the Western Desert, (namely) the Osiris, the King's Scribe, the Chief Steward in Memphis, Amenhotpe.*

Right. *An offering which the king gives (to) Osiris, Foremost of the West, the Great God, Lord of Rosetau, on behalf of the one in honour with Nūt, Mother of the Gods, (namely) the Osiris, the King's Scribe, the Chief Steward in Memphis, Amenhotpe.*

Although slightly irregular in shape, the palette is nicely made and is finished with a fine surface-polish. The cutting of the inscriptions is adept and sophisticated. The outlines of the \bigcirc -signs are, on the other hand, unaccountably rough and careless.

The palette had been broken into three fairly large and eleven small pieces, but, apart from a few minute chips out of its edges, it is complete and in good condition. At some time before its acquisition by the Metropolitan Museum it had been mended somewhat carelessly with a thick shellac (which with time had turned black) and had been mounted in a frame composed of a strip of brass bent around the edges of the palette and fastened to them by a series of small screws.⁴ This has been removed and the palette has been re-mended and mounted on a heavy brass plate, slightly shorter and narrower than the slab itself.

¹ MMA. accession No. 37.2.1. Purchased at a sale of 'Egyptian Antiquities . . . the property of a collector' at Christie, Manson & Woods, London, March 2, 1937 (see the sale *Catalogue*, p. 12, No. 47 and the accompanying illustration). Accession reported by Hayes, *An Egyptian Scribe's Palette*, *Bull. MMA* 32, 157-8. From the collection of M. Nahman of Cairo and Paris.

² See Glanville, *Scribes' Palettes in the British Museum*. Part I, *JEA* 18, 53, 58-60, Pls. iv 1, v 2, viii 1, 4; *Bull. A Group of Egyptian Antiquities*, *Bull. MMA* 27, 130-1, Fig. 1; Ranke, *Art of Ancient Egypt*, No. 302.

³ Petrie, *Measures and Weights*, 4. Cf. the palette of the Vizier Ptahmose in the Louvre (N 3026), which measures 52.5 cm., a royal cubit, in length (M. Saigey, *Traité de métrologie ancienne et moderne*, 15).

⁴ See Christie's *Catalogue*, illustration facing p. 12, No. 47.

The internal evidence (the name Amenhotpe, the style of the hieroglyphs and of the workmanship in general) points to a date for the palette fairly advanced in the eighteenth Dynasty. The invocation in the right-hand inscription of Osiris as Lord of Rosetau and the owner's title, *Chief Steward in Memphis*, suggest the latter town or its vicinity as the provenance of the piece. The nature of the monument indicates that it came originally from a tomb.

We are not, however, dependent only upon such general impressions and such epigraphic and stylistic *minutiae* in establishing its date and provenance, for the owner of this palette was a man of considerable prominence in his time and is represented by at least sixteen other monuments, scattered throughout the museums of Europe,¹ among which are two alabaster palettes similar to the one under discussion.

MONUMENTS OF THE CHIEF STEWARD AMENHOTPE (ALSO CALLED HUY)

(Hereinafter referred to by the letters A, B, C, etc.)

A. The SCRIBE'S PALETTE (funerary model) published in this article. New York, Metropolitan Museum of Art, Acc. No. 37.2.1.

B. SCRIBE'S PALETTE (funerary model), alabaster. Paris, Musée du Louvre, AF 483. (2nd) Salt Collection, Inv. No. 833.

[Nizzoli], *Memorie relative al gabinetto di antichità* (1824), in *Documenti inediti per servire alla storia dei Musei d'Italia*, IV, p. 372; Champollion, *Notice descriptive des monumens égyptiens du Musée Charles X* (1827), no. M. 51, p. 302; notes taken in the Louvre by H. E. Winlock (June, 1930), on file in the Metropolitan Museum; Boreux, *Guide-Catalogue sommaire, Département des antiquités égyptiennes, Musée National du Louvre*, part I (1932), p. 610, 'Vitrine IX'.

C. SCRIBE'S PALETTE (funerary model), alabaster. Florence, Museo Archeologico, 3080. (2nd) Nizzoli Collection, Inv. No. 133.

Museo Nizzoli, a. 1824, *Catalogo ed inventario*, in *Documenti inediti*, IV, 356; [Nizzoli], *Memorie* (1824), 372; [Migliarini], *Di un Cubito*, etc., *Biblioteca Italiana o sia giornale di letteratura, scienze ed arti*, 33 (1824), p. 47; Champollion, letter to Champollion-Figeac from Turin, August 14, 1824 (Hartleben, *Lettres de Champollion le Jeune*, I. *Lettres écrites d'Italie* (*Bibl. égyptol.*, xxx, p. 39); Champollion-Figeac, *Observations sur les coudées égyptiennes découvertes dans les ruines de Memphis*, in *Bulletin des sciences historiques, antiquités, philologie* (Section VII of *Bulletin universel des sciences et de l'industrie*), I (1824), no. 322, p. 289; Rosellini, I. *Monumenti dell'Egitto e della Nubia*, II. *Monumenti civili* (1834), Pl. LXVI;² O. Thenius, *Die althebräischen Längen- und Hohlmasse*. II. *Die altägyptischen Maßstäbe*, in *Theologische Studien u. Kritiken*, XIX, 1 (1846), 302; Sethe, *Über einige Kurznamen des neuen Reiches*, in *ZÄS* 44 (1907), 89; Boeser, *Beschr. Leiden. De Monumenten van het Nieuwe Rijk*, Afdeeling II (1912), p. 4; Bagnani, *Il Primo Intendente del Palazzo, Imenhotpe, detto Huy*, in *Aeg.* 14 (1934), 38-40, Fig. 2.

D. CUBIT-ROD (funerary model), alabaster. Florence, Museo Archeologico, 3078. (2nd) Nizzoli Collection, Inv. No. 132.

Museo Nizzoli (1824), 356; [Nizzoli], *Memorie* (1824), 372; Salt, letter to Sir William Gell from Alexandria, September 16, 1822 (Hall, *JEA* 2, 139); [Migliarini], *Di un Cubito*, etc. (1824), with a drawing; Champollion, letter to Champollion-Figeac from Turin, June 30, 1824 (Hartleben, *op. cit.*, 23-4); to the same from Turin, August 14, 1824 (Hartleben, *op. cit.*, 39); Champollion-Figeac, *Sur une Coudée*, in *Bulletin des Sciences*, I (1824) no. 321, pp. 280-1; *Observations sur les coudées*, (1824) (see under C), p. 289; *Supplément aux observations*, in *Bulletin des Sciences*; II (1824), no. 25, p. 21;

¹ Eight of these monuments have recently been re-published by G. Bagnani, *Aeg.* 14 (1934), 33-48.

² The palette is erroneously listed by Rosellini with a group of 'varj utensili e strumenti, che si trovarono nelle tombe tebane, . . . '.

Champollion, letter to Champollion-Figeac from Turin, October 30, 1824 (Hartleben, *op. cit.*, 78); E. F. Jomard, *Lettre à M. Abel Rémusat sur une nouvelle mesure de coudée trouvée à Memphis* (1827), with a drawing; Saigey (1834), *op. cit.*, 12–13, Pl. i; A. Böckh, *Die aegyptischen Längen- und Körpermasse. Metrologische Untersuchungen über Gewichte, Münzfüsse und Masse des Altertums in ihrem Zusammenhange*, Abschn. XIII (1838), 224–5; Amalia Nizzoli, *Memorie sull' Egitto e specialmente sui costumi delle donne orientali e gli harem, scritte durante il suo soggiorno in quel paese* (1819–28), pp. 83–4, 237–8 (1841); Thenius, *op. cit.*, pp. 297, 301–2, Fig. 5; Vazquez Queipo, *Essai sur les systèmes métriques et monétaires des anciens peuples*, etc., I (1859), Chap. I, pp. 44–5; Lepsius, *Die alt-aegyptische Elle und ihre Eintheilung*, in *Abh. Berlin*, 1865, 14–15, Pl. ii, b; Berend, *Principaux monuments du Musée égyptien de Florence*, pp. vi, 72;¹ Bagnani, *op. cit.*, pp. 40–6, Fig. 5.

E. STELA, limestone. Florence, Museo Archeologico, 2567. (2nd) Nizzoli Collection, Inv. No. 2.

Museo Nizzoli (1824), pp. 346–7; [Nizzoli], *Memorie* (1824), 371; Champollion, letter to Champollion-Figeac from Turin, June 30, 1824 (Hartleben, *op. cit.*, p. 24); Champollion-Figeac, *Supplément aux observations* (1824), p. 21; Champollion, letter to Champollion-Figeac from Florence, July 2, 1825 (Hartleben, *op. cit.*, 236); Saigey *op. cit.* (1834), 13; Lieblein, *Dict. des noms hiérog.* (1871), No. 652, p. 218; Wiedemann, *Une stèle du Musée égyptien de Florence*, in *Congrès provincial des orientalistes français, Compte-rendu de la première session*, II (1875), 145–6; Piehl, *Petites notes de critique et de philologie*, in *Rec. Trav.* 2 (1880), 124–5; Berend, *op. cit.*, 71–2; Schiaparelli, *Antichità egizie, Museo archeologico di Firenze, (Catalogo generale dei musei etc. Series VI, vol. I)* (1887), No. 1617, pp. 349–51; Sethe, *op. cit.*, 89; Boeser, *op. cit.*, 4; Bagnani, *op. cit.*, pp. 33–8, Fig. 1.

F. PYRAMIDION, gray granite. Florence, Museo Archeologico, 2610. (2nd) Nizzoli Collection, Inv. No. 63.

Museo Nizzoli (1824), 354; [Nizzoli], *Memorie* (1824), 372; Schiaparelli, *op. cit.*, No. 1675, p. 420.

G.-H. TWO JARS (inscribed), alabaster. Florence, Museo Archeologico, 2338, 2339. (2nd) Nizzoli Collection, Inv. Nos. between 83 and 110.

Museo Nizzoli (1824), 355; [Nizzoli], *Memorie*, 372, 373; Champollion, catalogue of the Nizzoli Collection (1825), Nos. 102, 103 (Pellegrini in *Bessarione*, 2nd Series, 5, 198); Sethe, *op. cit.*, 89; Boeser, *op. cit.*, 4; Bagnani, *op. cit.*, p. 40, Figs. 3, 4.

I.-K. THREE JARS (uninscribed), alabaster. Florence, Museo Archeologico. (2nd) Nizzoli Collection, Inv. Nos. between 83 and 110.

Museo Nizzoli (1824), p. 355; [Nizzoli], *Memorie* (1824), pp. 372, 373.

L. PYRAMIDION, red granite. Leiden, Rijksmuseum van Oudheden. D'Anastasy Collection, Inv. No. A.M. 6.

Leemans, *Description raisonnée des monuments égyptiens du Musée d'Antiquités des Pays-Bas à Leide* (1840), No. K. 1, pp. 137–8; *Monumens égyptiens du Musée d'Antiquités des Pays-Bas à Leide*, III (1846), No. K. 1, p. 1, Pls. i–ii; Holwerda, *Catalogus van het Rijksmuseum van Oudheden te Leiden Egyptische Afdeling*, Part I (1904), No. 36, p. 53; Sethe, *op. cit.*, 89; Boeser, *op. cit.*, (1912), No. 1, p. 1; Bagnani, *op. cit.*, p. 46, Fig. 6.

M. CANOPIC CHEST, quartzite. Leiden, Rijksmuseum van Oudheden. D'Anastasy Collection, Inv. No. A.M. 2.

Leemans, *Description* (1840), No. S. 1, p. 221; Holwerda, *op. cit.*, No. 37, p. 53; Sethe, *op. cit.*, 89 ('Sarge'); Boeser, *op. cit.*, No. 5, pp. 2–4, Pl. ii; Bagnani, *op. cit.*, p. 46, Fig. 7.

¹ Berend makes two misstatements concerning the cubit rod: (a) that it was acquired by the Florence Museum in 1829–30 (it is included in the 1824 catalogue, see *Museo Nizzoli*, 356), and (b) that it was published by Nizzoli in 1831, reference not given (there is no trace of any such publication). He also misquotes the inscription on the rod, p. 72 (*cf.* Lepsius, *op. cit.*, Pl. ii, b; etc.).

N. LEG OF A STOOL, wood. Leiden, Rijksmuseum van Oudheden. D'Anastasy Collection. Leemans, *Description* (1840), No. H. 551, p. 97; *Monumens*, II (1842), No. H. 551, pp. 49–50, Pl. lxxiv; Holwerda (1904), *op. cit.*, 53.

O. STELA, quartzite. Cairo, Egyptian Museum.

Quibell, *Monastery of Apa Jeremias* (1912), pp. 6, 146, Pl. lxxxiv; Bagnani, *op. cit.*, pp. 46–8, Fig. 9; Porter-Moss, *Top. Bibl.* III (1931), 178.

P. STATUE, quartzite. Oxford, Ashmolean Museum.

Gardiner, *ap. Petrie, Tarkhan I and Memphis V* (1913), 33–6, Pls. lxxvii (lower right) lxxx; Porter-Moss (1931), *op. cit.*, 218.

Q. STATUE, gray granite. London, British Museum, 448.

Petrie and Griffith, *Abydos*, II (1903), pp. 35–6, 45, Pls. xxxii, 11 (lower right), xxxvi; [Budge], *Guide to the Egyptian Galleries (Sculpture)*, *British Museum* (1909), No. 448, p. 127, Pl. xvii; *Hierog. Texts BM.* v (1914), No. 448 [632], p. 11, Pl. xxxviii.

(The statement of Lepsius, *Abh. Berlin*, 1865, 15, that the same Amenhotpe is the owner of a stela in Turin and a 'green basalt' palette in the Louvre, is erroneous.¹ Nor can I see that Holwerda, *op. cit.*, 53, has sufficient basis for assigning to him two alabaster *shawabtis* and a carnelian amulet in the Rijksmuseum at Leiden.²)

With the exception of the two statues (P and Q), all the monuments listed above are obviously items of tomb equipment or decoration. The quartzite stela (O) was found by Quibell in the ruins of the monastery of Apa Jeremias at Saqqārah, whither it had been brought (probably from the vicinity) by the ancient monks and used for many years as a door-sill.³ All the remaining monuments (A–N) appear to have been found in Amenhotpe's tomb at Saqqārah some time during the years 1821–2.

Four well-known collectors were involved in the acquisition and transportation to Europe of these monuments:

(a) Giuseppe di Nizzoli, Chancellor of the Austrian Consulate in Egypt from about 1818 to 1828.⁴ Following the sale of his first collection of antiquities to the Imperial Court of Austria at Vienna in 1820⁵ Nizzoli returned to his post in Egypt and, either personally or

¹ I am assured by Dr. Farina of the Museo di Antichità, Turin, and by M. Boreux of the Louvre that no such monuments of Amenhotpe are to be found in their respective museums.

Lepsius obviously took his error regarding the stela directly from Böckh, (see p. 11, under D), p. 224, who makes the same misstatement and gives as his reference Gazzera, *Applicazione delle dottrine del Signor Champollion Minore ad alcuni monumenti geroglifici del Regio Museo Egizio*, in *Memorie della Reale Accademia delle Scienze di Torino*, 29 (1825), *Memorie della classe di scienze morali, storiche e filologiche*, Fig. 6 A [Pl. 12]. When the latter reference was checked it was found that Böckh's 'stela' is in reality a Twenty-first Dynasty coffin belonging to a man named Amenhotpe, who, like scores of others of his period, was a 'King's Scribe in the Place of Truth'.

The statement of Lepsius concerning the 'green basalt' palette is clearly the result of a confusion of the alabaster palette of Amenhotpe (B) with the schist palette of Ptaḥmose, which is also in the Louvre (AF 481), and may have been due to a careless reading of Vazquez Queipo, *Essai* (see p. 11, under D), p. 45, items 6–7.

² The owner of the *shawabtis* (Leemans, *Description*, Nos. P. 73, 74, p. 209) was a King's Scribe named Amenhotpe—by no means necessarily the Amenhotpe in whom we are interested.

The amulet (Leemans, *Description*, no. B. 585 (*sic*), p. 32; *Monumens*, I, no. B. 578, p. 21, pl. xxvi) is from the de l'Escluze Collection, purchased at Antwerp in 1826. It is inscribed with the title and name of a Chief Steward, Amenhotpe.

³ Quibell, *op. cit.*, pp. 6, 146.

⁴ See the memoirs of his wife, Amalia Nizzoli (quoted p. 11, under D).

⁵ Amalia Nizzoli, *op. cit.*, 83–4.

through an agent, resumed his excavations in the Memphite necropolis.¹ The area in which he conducted his operations was situated 'at Saccarah,² near Memphis, on the chain of hills which separates the left bank of the Nile from the sands of the deserts . . . not more than a quarter of an hour' from 'the town of Memphis'.³ In 1821 or early in 1822,⁴ while working in this area, he cleared, or helped to clear,⁵ the tomb of the Chief Steward Amenhotpe,⁶ and obtained from it the limestone stela (E), the five alabaster jars (G–K), the small granite pyramidion (F), the fragments of apparently all three of the palettes (A–C), and five of the seven extant pieces of the cubit-rod (D).⁷ He also found in the tomb 'a very large sarcophagus of ash-coloured granite, the lid of which was broken to pieces'.⁸ Being unable to remove the sarcophagus, he was forced to abandon it in the tomb,⁹ where it probably still reposes. Monuments C–K were included in the collection of 1408 pieces which Nizzoli on September 28, 1824 sold to the Grand Duke Leopold II of Tuscany.¹⁰ The collection was installed in the Uffizi¹¹ at Florence and, after several moves, had arrived by 1882 in the present Museo Archeologico.¹² At the time of its purchase from Nizzoli the collection was catalogued,¹³ apparently by G.-B. Zannoni,¹⁴ and in 1825 by Champollion.¹⁵ Nizzoli seems to have disposed of the palettes A and B¹⁶ (which are practically duplicates of C) either in Egypt or in Europe some time during the years 1822–3, certainly before September, 1824, as they are not, of course, included in the Zannoni catalogue.

¹ Amalia Nizzoli, pp. 83–4. In 1824–5, and perhaps from 1821 to 1828, his wife acted as his representative at Saqqārah (*ibid.*, *op. cit.*, 244–7).

² *i.e.*, near the village of Saqqārah. The name in those days apparently was not applied, as it commonly is to-day, to the whole of the region between Abušir and Dahshūr.

³ [Nizzoli], *Memorie*, 371.

⁴ On September 17, 1822, Nizzoli left Egypt for the second time, taking with him (in his second collection) the cubit-rod, and the other objects which fell to his share, from Amenhotpe's tomb (Amalia Nizzoli, *op. cit.*, 83–6).

⁵ With Anastasy (?). See below. Neither Nizzoli nor his wife lay claim to his having discovered the tomb.

⁶ [Nizzoli], *Memorie*, pp. 371, 372–3; Amalia Nizzoli, *op. cit.*, 83–4, 244–5; Hartleben, *Lettres de Champollion* (see p. 10, under C), pp. 24, 39; [Migliarini], *Di un Cubito*, p. 47; etc.

⁷ [Nizzoli], *Memorie*, pp. 371, 372–3; Amalia Nizzoli, *op. cit.*, 244–5; [Migliarini], *Di un Cubito*, p. 47; Hartleben, *op. cit.*, 24, 39; etc.

⁸ [Nizzoli], *Memorie*, 372.

⁹ 'Come e da qual parte fu introdotto colà quel gran sarcofago? Non essendo in modo alcuno possibile di farlo uscire dall' apertura che era assai stretta bisognò abbandonarlo' (Amalia Nizzoli, *op. cit.*, 244–5). In addition to the burial-pits through which Nizzoli entered the tomb there may have been, for the sarcophagus, a larger pit or slide, of which the early nineteenth-century excavators were unhappily unaware. An alternative suggestion is that the small size of the pits as found may have been due to a stone lining, which had been built after the introduction of the sarcophagus.

¹⁰ *Documenti inediti*, p. xi; Amalia Nizzoli, *op. cit.*, 125; Hartleben, *op. cit.*, pp. 234, 238. The history of the collection from the time of its departure from Alexandria on September 17, 1822, to the time of its sale to Leopold II can be traced step by step. See Amalia Nizzoli, *op. cit.*, 83, 85, 86, 104, 106, 109; [Migliarini], *Di un Cubito*, 46; Hartleben, *op. cit.*, 23–4.

¹¹ Berend, *Principaux monuments du Musée égyptien de Florence*, p. v.

¹² Berend, *op. cit.*, pp. v–vi.

¹³ *Museo Nizzoli*; see *Documenti inediti*, pp. viii ff., 346 ff.

¹⁴ Co-director, with Alessandri, of the 'Gallerie' at Florence (Hartleben, *op. cit.*, 234, 236). The catalogue was evidently not made by Nizzoli himself, for in it the descriptions of the objects vary considerably from those given by Nizzoli in the *Memorie*.

¹⁵ Pellegrini, in *Bessarione*, 2nd Series, 5, 187 ff.; Hartleben, *op. cit.*, 234, 236, 238.

¹⁶ They must certainly have been in his possession for a time, for, in addition to the Florence palette (C), he mentions having found in the tomb 'altri pezzi di altre palette a colori' (*Memorie*, 372). On the manner of their disposal and their probable receivers see below.

(b) J. d'Anastasy, Consul for Sweden at Alexandria from before 1820 to at least 1827.¹ He appears to have served also as the Danish Consul.² More relevant to the discussion which follows is the fact that he seems to have had close and friendly relations with the Austrian Consulate and its personnel.³ His activities in the third decade of the nineteenth century cannot be traced in such detail as those of Nizzoli. In 1820 Anastasy was in Lower Egypt and had already assembled a considerable collection of antiquities.⁴ He was almost certainly working the necropolis at Saqqārah at this time and we have the word of Signora Nizzoli and others for the activities of his agents there in 1823–5.⁵ By 1826 he had established his agent, Piccinini, at Thebes⁶ and had probably transferred his major operations thither. In May of the same year he was preparing to ship his collection to Europe,⁷ but delayed the shipment, presumably until the more important items from his Theban work could be added to it. The collection finally arrived at Leghorn in the late summer of 1827,⁸ and in 1828 it was purchased by the Netherlands government and added to the already existing Egyptian collection at Leiden.⁹ Three of the objects which Anastasy sold to Leiden at this time came from the tomb of the Chief Steward Amenhotpe (Monuments L–N)—the same tomb from which Nizzoli recovered the Florence pieces discussed above. The stool leg (N) might have been purchased from Nizzoli's workmen without the latter's knowledge. This is, however, far from being the case with the granite pyramidion (L) and the quartzite canopic chest (M), both of which are of considerable size and weight. The presence of these two monuments in Anastasy's collection points strongly to the conclusion that he also conducted excavations in the tomb, and perhaps was its discoverer.¹⁰ Certain details which have come down to us regarding the clearing of the tomb suggest that Anastasy, after the discovery, cleared it in partnership with Nizzoli,¹¹ and that the two excavators divided the proceeds of their combined

¹ Baroness von Minutoli, *Recollections of Egypt*, 20; Amalia Nizzoli, *op. cit.*, 236; Thenius in *Theol. St. Kr.*, XIX 1, p. 303; Jomard, *Lettre* (see p. 11, under D), 19; Lenormant, *Catalogue d'une collection d'antiquités égyptiennes rassemblées par M. d'Anastasy* (Paris, 1857).

² He is so referred to by Leemans, *Description* (see p. 11, under L), vii.

³ As witnessed by the facts that:

(a) Champollion (Hartleben, *op. cit.*, 94) calls him 'le Consul Général d'Autriche'—an error, but an error unquestionably fostered by the close association in Champollion's mind of Anastasy and the Austrian Consulate.

(b) At a time when safe passages to Europe were almost impossible to obtain, Anastasy was able to arrange that the Baron and Baroness von Minutoli should be transported to Trieste on an Austrian ship (Minutoli, *op. cit.*, 230).

(c) In 1824–5, although Anastasy appears to have been engaged in endless squabbles with other excavators, Nizzoli and his wife found no reason to complain of him.

⁴ Minutoli, *op. cit.*, p. 20.

⁵ Amalia Nizzoli, *op. cit.*, 236; Jomard, *Lettre*, 19; Thenius, *op. cit.*, 303; Lepsius, *Abh. Berlin*, 1865, 15.

⁶ Lenormant, *op. cit.* I am indebted to Mr. Winlock for this reference; the publication is not obtainable in New York.

⁷ Hartleben, *op. cit.*, 346–7.

⁸ *Ibid.* 347, n. 1; see also p. 422.

⁹ *Ibid.* p. 347, n. 1; Leemans, *Description* (see p. 11, under L), vii; *Monumens* (see p. 11, under L), i, Preface.

¹⁰ The pyramidion (L) was probably found lying on the ruins of the superstructure of the tomb, and would in that case have been the first object found, may indeed have led to the discovery of the tomb itself.

¹¹ Even granting that the work of Anastasy's agents may have been far from thorough, the following facts cannot be explained away:

To reach the canopic chest (M) in the burial chamber of the tomb, Anastasy's workmen had to pass through a chamber, in one wall of which the Florence stela (E), 118 × 67 cm., would have been still upright, *in situ* ([Nizzoli], *Memorie*, 371). In removing *only* the canopic chest (and the stool leg, N) these same workmen would have had to ignore the 'very large' granite sarcophagus, which was presumably in the same cham-

work, Monuments A–K going to Nizzoli and (C–K) to Florence, Monuments L–N to Anastasy and Leiden.¹

(c) Henry Salt, British Consul-General in Egypt from 1816 to his death, near Alexandria, on October 30, 1827.² As late as 1825 Salt maintained an agent in the Memphite necropolis, through whom, according to Amalia Nizzoli,³ he conducted ‘vast excavations’ there. In the early Fall of 1822 he himself was in the vicinity of Saqqārah, and in a letter written to Sir William Gell from Alexandria on September 16th of that year he mentions the recent discovery at Saqqārah of three cubit-rods,⁴ one of which was certainly Nizzoli’s. At some time during the years 1822–4—probably in 1822—Salt sold or traded to Nizzoli a papyrus which in 1824 went with Nizzoli’s second collection to Florence.⁵ It was probably at the same time and perhaps as part of the same transaction that Salt obtained from Nizzoli the second of the three palettes from the tomb of Amenhotpe (B). In any event, the palette was added to Salt’s second collection of antiquities, and as part of that collection was sold to the Louvre on February 23, 1826.⁶ It is listed in the catalogue which Champollion in 1827 drew up of the Louvre’s newly installed Egyptian galleries.⁷

(d) The Chevalier Drovetti, Consul-General for France,⁸ who in the years 1820–5 was amassing the second of his great collections of antiquities.⁹ There can be no doubt that Drovetti (or his agent) was busy at Saqqārah at the time of the discovery of Amenhotpe’s tomb,¹⁰ and that he and Nizzoli were in the habit of exchanging antiquities with one another.¹¹ After the latter’s departure on September 17, 1822,¹² Drovetti purchased from natives two of the three missing pieces of the cubit-rod (D)¹³ and forwarded them to Nizzoli, who had by this time reached Florence,¹⁴ but had not yet sold his collection to the museum there. Of the

ber as the chest and which contained the Florence palette (C), the cubit rod (D), the pyramidion (F), and fragments of several of the alabaster jars (G–K) ([Nizzoli], *Memorie*, 372, 373).

It is undeniably strange that neither Nizzoli nor his wife mention a partnership with Anastasy or any of the objects which Anastasy obtained from the tomb. This is, however, not altogether inexplicable. Nizzoli’s *Memorie* accompany a catalogue of objects which he was on the point of selling to the museum at Florence, and the comments which he makes in these notes are naturally confined to the objects catalogued. Signora Nizzoli may not have wished to detract from her own and her husband’s distinction in having excavated the tomb by admitting that they did so only as associates of the famous Anastasy. Attention must once more be called to the fact that, in spite of their very natural desire to rank first as the exploiters of the tomb, neither of the Nizzolis anywhere lays claim to having discovered it.

¹ This would have been by no means the only time that Nizzoli and Anastasy appear to have divided the contents of a single Memphite tomb. Other Saqqārah tombs, objects from each of which are to be found both in the Nizzoli collections at Florence (or Vienna) and the Anastasy collection at Leiden, are those of the High Priest Ptaḥmose, the King’s Scribe Ptaḥmose, and the General (later king) Haremḥab. See Porter-Moss, *Top. Bibl.*, III, pp. 191, 192, 195–6; Capart, *The Memphite Tomb of King Haremḥab*, *JEA* 7, 31–2; and the catalogues of the Florence and Leiden Museums.

² J. J. Halls, *Life and Correspondence of Henry Salt*, see especially I, 451, II, 279; Hall, *Letters to Sir William Gell from Henry Salt, etc.*, *JEA* 2, 133 ff. ³ *Op. cit.*, 236.

⁴ Hall, *op. cit.*, 139.

⁵ *Museo Nizzoli*, p. 366, No. 1290; [Nizzoli], *Memorie*, p. 376.

⁶ This valuable information, drawn from the MS. inventory of the Salt collection, I owe to the courtesy of M. Charles Boreux, Curator of the Louvre’s Egyptian Department.

⁷ Champollion, *Notice descriptive des monumens égyptiens du Musée Charles X* (1827), No. M. 51, p. 102.

⁸ Consul to 1815, Consul-General from 1821 on. See Minutoli, *op. cit.*, 14–16; Salt, letter to Wm. Hamilton from Alexandria, November 6, 1821 (Halls, *op. cit.*, 191); Hartleben, *op. cit.*, 302–3.

⁹ Minutoli, *op. cit.*, 3, 14–16, 113, 153, 175.

¹⁰ Amalia Nizzoli, *op. cit.*, 236.

¹¹ [Nizzoli], *Memorie*, 375.

¹² Amalia Nizzoli, *op. cit.*, 85–6.

¹³ See above, p. 13, n. 7.

¹⁴ Amalia Nizzoli, *op. cit.*, 237–8; [Migliarini], *Di un Cubito* (see p. 10, under C), 45–6; Jomard, *Lettre* (see p. 11, under D), 14.

three practically identical palettes (A, B, and C) originally included in Nizzoli's collection¹ (C), as we have seen, went to the Florence museum, and (B) to Salt and, through him, to the Louvre. There is no record of the New York palette (A), from the time it was in Nizzoli's possession until it was obtained some years ago by M. Nahman from 'an old collection' in Paris.² It is, however, not unlikely that in 1822 or 1823 Nizzoli gave or traded the fragments of the palette to Drovetti in return for the pieces of the cubit;³ and that several years later the palette was taken to Paris by Drovetti when he was negotiating the sale of his second collection to the Louvre. The collection was purchased by the Louvre in September, 1827,⁴ but the palette, being practically a duplicate of one already in the Louvre (B), was not included in the purchase. It was probably disposed of by Drovetti to a private collection in Paris, where it remained until its acquisition by Nahman. With its subsequent history we are familiar (see above, p. 9, n. 1).

THE TOMB OF THE CHIEF STEWARD AMENHOTPE AT SAḲḲĀRAH

The information which Nizzoli and his wife have passed on to us concerning the tomb at SaḲḲārah from which they and Anastasy extracted Monuments A–N and from which unquestionably came also Quibell's stela (O), is scanty and not always clear and consistent.⁵ The tomb, however, appears to have conformed to a type which was common in the late Eighteenth Dynasty and which is represented by examples both at SaḲḲārah and elsewhere. This fact, and the special character of some of the monuments from the tomb, allow us to reconstruct a fairly clear picture of it.

The tomb proper consisted of two subterranean chambers, access to which was gained by two long pits, the first leading from ground-level to the first chamber, or what we may call the *antechamber*, the second descending from the antechamber to the *burial-chamber*. Both pits were intended as burial-shafts only, and were too small to have permitted the insertion or removal of the sarcophagus, which may have been lowered into the burial-chamber through another and larger shaft, specially designed for the purpose.⁶

Set in one of the walls of the antechamber was the limestone stela, (E), dedicated to Amenhotpe by his son Ipy and representing father and son seated face to face on either side of an offering table, the figure accompanied by the usual offering formulae.⁷ The chamber appears to have been otherwise undecorated, but the presence of the stela in it identifies it as a sort of subterranean chapel⁸ and correlates it with the inscribed chamber in, for example, the tomb of Senmūt at Dēr el-Baḥri.⁹

¹ See above, p. 13, n. 16.

² Letter, May, 1937, from M. Nahman to H. E. Winlock, on file in the Metropolitan Museum.

³ We can hardly doubt that Nizzoli was enormously grateful for the additions to his cubit—an object in which he took special pride (Amalia Nizzoli, *op. cit.*, 83–4) and which was at the time attracting widespread attention (see the early references under D, above). Drovetti, on the other hand, has not the reputation of a man who performed acts of generosity without expectation of adequate returns.

In addition to the pieces of cubit-rod, Nizzoli (as he himself tells us, *Memorie*, 375) also obtained from Drovetti in 1822–3 several scarabs. It was perhaps these, not the cubit fragments, that Drovetti exchanged for the palette.

⁴ Hartleben, *op. cit.*, 421, 424.

⁵ [Nizzoli], *Memorie*, 371, 372–3; Amalia Nizzoli, *op. cit.*, 244–5. Except where specified, all the data on the tomb presented below are drawn from these two sources.

⁶ Cf. Bruyère, *Rapport sur les fouilles de Deir el Médineh* (1924–5), (*Fouilles de l'Institut*, III, 3), Figs. 6–3. See above, p. 13, n. 9.

⁷ The long and interesting text below the figures has been translated by Wiedemann, *op. cit.* (see p. 11, under E), by Schiaparelli, *Antichità egizie* (see p. 11, under E), pp. 350–1, and by Bagnani, *Aeg.* 14, 35–8.

⁸ Inaccessible once the burial had been made and the tomb sealed up.

⁹ Winlock, in *Bull. MMA* 23 (1928) February, Sect. II, 34–7, Figs. 36–44.

The burial chamber, or, perhaps better, 'crypt', seems to have been completely undecorated, as is usual in private tombs of this date. In this chamber were Amenhotpe's gray granite sarcophagus and, without doubt, his quartzite canopic chest (M). In the sarcophagus were found the small granite pyramidion (F),¹ the cubit-rod (D), at least one (C) of the alabaster palettes, and several of the alabaster jars (G-K).

As was usual, the tomb appears to have been surmounted, above ground, by a brick (?) chapel, from the floor of which the first pit descended to the subterranean rooms.² It must have been from this chapel, or its ruins, that the monks of the monastery of Apa Jeremias, about the middle of the first millennium A.D., extracted the quartzite stela (O). On this stela Amenhotpe and his wife Mey are depicted in the act of adoring the divinities Osiris, Ptah, Isis, and Hathor.

The large granite pyramidion (L) indicates that, as with the Eighteenth Dynasty tombs at Dēr el-Medīnah,³ the chapel was topped by a small, steeply-angled pyramid, probably of brick, of which the Leiden monument formed the cap-stone.⁴ The sides of the pyramidion (hence, those of the pyramid) slope sharply upward at an angle of about 2 in 1. On the front and back surfaces of the monument Amenhotpe is depicted kneeling in the doorway of his tomb and adoring the rising and setting sun, the accompanying texts being the two hymns which he sings to the sun.

The tomb was plundered probably long before the visit of the monks of Apa Jeremias, and when Nizzoli and Anastasy entered it all that remained of its original contents were those monuments which, because of their material, shape, or strictly funerary nature, were useless to any of the several categories of tomb-robber. The lid of the sarcophagus had been prized off and smashed to pieces in the process, the sarcophagus gutted of jewelry and other metal objects, the bones of the deceased scattered about the burial-chamber, and the coffins carried off for the sake of the wood of which they were made. The canopic chest had also been opened and the jars taken away, probably to be re-used in their original role, or as ordinary household receptacles. Of furniture there remained only the leg of a folding stool with a foot in the form of the head of an aquatic bird,⁵ inscribed with the name and titles of Amenhotpe (N). The small granite pyramidion (F), the alabaster cubit-rod (D), and the three palettes (A-C) naturally did not appeal to the plunderers, but most of these were broken to bits through carelessness or sheer vandalism. Five alabaster jars (G-K) had suffered the same fate. Probably in more recent times brick- and stone-thieves (among whom unfortunately we must include the pious brethren of Apa Jeremias) accounted for the superstructure of the tomb and the slabs of relief which may have lined the chapel and the ante-chamber, sparing only the large granite pyramidion (L), which by reason of its shape was utterly useless except for the purpose for which it had been made.

¹ A model or symbol of the considerably larger cap-stone of the tomb's superstructure, small enough to be placed in the immediate presence of the deceased, thereby facilitating his going forth to greet the sun. Like its larger counterpart it bears a hymn to the sun, recited by the deceased.

² Cf. Quibell and Hayter, *Teti Pyramid, North Side (Service des Antiquités)*, pp. 10-11, 32 ff., Pls. 2, 8 ff., see especially p. 10 and Pl. 8.

³ Bruyère, *Deir el Médineh (Fouilles de l'Institut, 1922-23, vol. I, pt. 1)*, pp. 51-4, 57-8, Pls. xv-xvi, xx; *Rapport sur les fouilles de Deir el Médineh (1923-4)*, pp. 8-15 (see especially pp. 13, 14-15), Pls. vii, viii, xiv, xv, xxx; *Rapport (1924-5)*, pp. 5-14, Figs. 3, 5-8; *Rapport (1927)*, pp. 118-19, Figs. 80, 81; *Rapport (1928)*, pp. 29, 95-6, Figs. 19, 53.

⁴ Pyramidal cap-stones from a number of other private tombs in the Eighteenth-Dynasty cemetery at Saqqārah are published by Boeser, *Beschr. Leiden*, Afdeling II, (see p. 10, under C), Nos. 2, 3, 4, Pls. i, xv-xvi (all three from Anastasy's collection), and Schiaparelli, *Antichità egizie* (see p. 11, under E), Nos. 1676-8, pp. 420-3.

⁵ Cf. Carter, *Tomb of Tutankhamen*, III, p. 112, Pl. xxxiii.

We learn from Nizzoli that the tomb was situated on the hilly ground at the edge of the desert, not far from Mît-Rahīnah and probably in the vicinity of the village of Saḳḳārah. This would place it in the area adjacent to the desert end of the principal embankment leading from the cultivation to Saḳḳārah—the ‘Rās el-Gisr’,¹—a hypothesis confirmed by the presence of the large quartzite stela from the chapel of the tomb in the monastery of Apa Jeremias. The tomb, at all events, was not an isolated phenomenon, but part of an extensive upper-class cemetery of the late Eighteenth and early Nineteenth Dynasties, which extended along the desert’s edge from beyond the pyramid of Tety on the north² to the pyramid of Unis on the south.³ The north and south ends of this cemetery have been excavated in relatively recent times and the positions of the Eighteenth-Dynasty tombs in these sections are therefore known.⁴ In the area between, much dug over, but nowhere cleared, lie in all probability the many fine tombs of the New Kingdom which have furnished the museums of Europe with blocks of relief, stelae, and other objects, but which Porter-Moss have had of necessity to class under the heading ‘position unknown’. Noteworthy among the owners of these tombs are such close contemporaries of our Chief Steward as the High Priest Ptaḥmose,⁵ the King’s Artificer Peatenemḥab,⁶ the Merchant Huy,⁷ and the General (afterwards king) Ḥaremḥab.⁸ The tomb of Ḥaremḥab appears to be situated close to that of the Chief Steward Amenḥotpe in the neighbourhood of the Rās el-Gisr, for blocks of relief from it were found, like Amenḥotpe’s stela, in the monastery of Apa Jeremias.⁹ It should also be noted that the majority of the pieces from the tombs of Ptaḥmose, Peatenemḥab, and Ḥaremḥab—now in the museums at Florence, Bologna, and Leiden—were found by Nizzoli and Anastasy.¹⁰

HIS STATUES

From many points of view the most interesting, certainly the most informative, of Amenḥotpe’s monuments are his two statues (P, Q).

The quartzite statue (P), in the Ashmolean Museum at Oxford, lacks its head, but is otherwise in fairly good condition. The type is a familiar one: a scribe seated cross-legged, holding on his lap a half-open papyrus roll on which he has been writing. The long inscription,¹¹ which starts on the open section of the roll on the lap of the figure and continues on the top, front, sides, and back of the base, begins with a statement to the effect that the statue was granted as a favour to Amenḥotpe by King Amenophis III and was placed in the latter’s temple,¹² ‘United-with-Ptah’, situated in the cultivated land west of the city of Memphis. This is followed by a long and very interesting biographical text, of which more anon. The inscription ends with the customary exhortation to passers-by to honour the tomb and the memory of the statue’s owner, whose virtues are described with the usual enthusiasm. The statue was found in 1912 by Professor Petrie within the temenos area of Ptaḥ at Memphis. It lay near the north temenos wall, the site of which is marked to-day by the path leading eastward from the north end of the village of Mît-Rahīnah.¹³ It was unquestionably one of

¹ See Quibell, *Excavations at Saqqara* (1906–7), 63.

² Porter-Moss, *Top. Bibl.*, III, 126, 145; Firth and Gunn, *Teti Pyramid Cemeteries*, I, 3, 66–83; Quibell and Hayter, *Teti Pyramid, North Side*, 3, 10–11.

³ Porter-Moss, *op. cit.*, 175–7.

⁴ See above, ns. 2, 3.

⁵ Porter-Moss, *op. cit.*, 191.

⁶ *Ibid.*

⁷ *Op. cit.*, 192.

⁸ *Op. cit.*, 195–7.

⁹ *Op. cit.*, 179, 196; Bagnani, *Aeg.* 14, 48.

¹⁰ See Porter-Moss, *op. cit.*, 191, 195–6; Capart, *JEA* 7, 32; and the catalogues of the Florence and Leiden museums.

¹¹ Translated, with commentary, by Gardiner, *ap. Petrie, Tarkhan I and Memphis V*, pp. 33–6.

¹² See Gardiner, *op. cit.*, pp. 35–6.

¹³ Petrie, *op. cit.*, pp. 32–3.

several statues of Amenophis III's favoured officials which stood in the outer court of his temple, just inside the main gateway, flanking the way along which priests and other privileged persons passed to reach the sanctuary.¹ Striking is the very close similarity of this statue to the Metropolitan Museum's statue of General Haremhab, which appears also to have come from a temple in the temenos area of Ptah, perhaps from the great temple of Ptah himself.²

Of a different, but even more common type, Amenhotpe's gray granite statue in the British Museum (Q) represents its owner in a squatting posture, the knees drawn up before the chest, the forearms crossed over the knees. On its head the figure wears the fairly long and flowing wig, composed of innumerable small locks, which came into fashion toward the end of the Eighteenth Dynasty. The face is modelled with more care and delicacy than is usual on statues of this class, and is unquestionably the best portrait which we possess of the man with whom we are dealing. The eleven-line inscription on the front of the legs of the figure is a combined offering-formula and hymn to Osiris Onnophris.³ The statue is from the Eighteenth-Dynasty temple in the old temenos-area at Abydos. It was found, *in situ*, just inside the pylon of Tuthmosis III, a trifle to the left of the axis of the gateway.⁴ Beside it stood a similar statue of another Memphite, the Vizier Pereshotpe, an official of the reign of Ramesses II.⁵ The statue of the Chief Steward Amenhotpe was probably set up by the temple gate on the occasion of the additions made to the front of the building in the reign of Amenophis III.⁶

HIS TWO NAMES

In common with dozens of other Amenhotpes our Chief Steward bore also the shorter and less formal name $\overline{\text{H}}\text{uy}$.⁷ Indeed, it was probably by the latter name that he was generally known to his contemporaries, though it is of course less frequent than Amenhotpe in the inscriptions on the monuments. 'Huy' occurs, used alternatively with 'Amenhotpe', on Monuments E, M, and O, and as the sole name preserved on F.⁸ It appears on the monuments 8 times in all, as compared with the 37 times that the name Amenhotpe is used.

HIS TITLES AND EPITHETS

(The letters in the parenthesis following each title designate the monuments on which the title occurs. The numeral accompanying each letter indicates the number of times the title occurs on that particular monument. The final numeral in each parenthesis represents the total number of times that the title occurs.)

Traditional Titles:⁹ *rpsty* 'Hereditary Prince' (D, 3; L, 1; N, 1; O, 2; P, 1: 8); *hsty-c* 'Count' (D, 3 ?; L, 1; N, 1; O, 2; P, 1: 8); *sdwty (?) bity* 'Treasurer of the King of Lower Egypt' (L, 1; O, 1: 2); *smr wty* 'Sole Companion' (L, 1: 1); *smr c; n mrwt* 'Greatly Beloved Companion' (D, 1: 1); *smr c; n Nb Trwy* 'Great Companion of the Lord of the Two Lands' (N, 1: 1); *hry-d; d; (?) nsu* 'Attendant of the King' (F, 1; O, 1: 2); *sb* 'the Worthy' (Q, 1: 1).

Priestly Titles: *hm-ntr Wrt-hkrw* 'Priest of Weret-hekau' (L, 1: 1); *imy-r hmw-ntr m*

¹ Cf. Legrain, pp. 13-32, Pls. i-iii; Winlock, *Haremhab*, in *Bull. MMA* 18, October, Part II, 4; *Statue of Horemhab*, in *JEA* 10, 4; Hayes, *Statue of the Herald Yamu-nedjeh*, *Ann. Serv.* 33, 8-9.

² Winlock, *Haremhab* (see n. 11); *Statue of Horemhab* (see n. 11). If anything, the Oxford statue, though deprived of its head and somewhat battered, is superior in style and quality to the statue of Haremhab.

³ Translated by Griffith, *ap. Petrie, Abydos II*, 45.

⁴ Petrie, *Abydos II*, p. 36, Pl. lviii.

⁵ *Op. cit.*, pp. 36, 45, Pl. lviii ('figure of Rahotep').

⁶ *Op. cit.*, pp. 18-19, Pl. lviii.

⁷ See Ranke, *Personennamen*, I, p. 30, 12; Sethe, *ZÄS* 44, 89; Bagnani, *Aeg.* 14, 48.

⁸ But the end of the inscription, with a recurrence of the titles and almost certainly the name of the owner of the monument, is in this case mutilated.

⁹ Honorary and without function.

Ht-Slymt 'Overseer of Priests in the House of Sakhmet'¹ (L, 1: 1); *imy-wrt* 'Imy-weret Priest' (Q, 1: 1); *sšmw hb(w) n Pth rsy-ḥnb·f n ntrw nbw Inbw-ḥd* 'Leader of the Festival(s) of Ptah South-of-his-Wall and of all the gods of Memphis' (L, 1: 1).

Titles as Architect and Administrator: *imy-r kwt m Hnmt-Pth* 'Overseer of Works in "Khenmet-Ptah"' (L, 1: 1); *hryp kwt* 'Controller of Works' (P, 1: 1); *imy-r šnwtj m t3 r-dr-f* 'Overseer of the Double Granary in the entire Land' (L, 1: 1); *imy-r prw n ḥd nbw* 'Overseer of the Houses of Silver and Gold' (Q, 1: 1).

Titles as Scribe: *sš* 'Scribe' (O, 1: 1); *sš nsw* 'King's Scribe' (A, 2; B, 2; C, 2; D?, E, 2; F, 1; G, 1; H, 1; L, 3; M, 12; N, 1; O, 4; Q, 2: 33); *sš nsw mꜣ mry·f* 'Veritable Beloved King's Scribe' (L, 1; M, 7; P, 1: 9); *sš nsw nfrw* 'King's Scribe of the Recruits' (L, 1: 1).

Titles as Steward: *imy-r pr* 'Steward' (E, 1; F, 1; M, 1; O, 1: 4); *imy-r pr n Mn-nfr* 'Steward of Memphis' (Q, 1: 1); *imy-r pr wr* 'Chief Steward' (E, 1; H, 1; L, 1; M, 9; N, 1; O, 2; P, 1: 16); *imy-r pr wr (n) nsw* 'Chief Steward of the King' (G, 1; O, 2; Q, 1: 4); *imy-r pr wr n Mn-nfr* 'Chief Steward of Memphis' (M, 1; Q, 1: 2); *imy-r pr wr m Mn-nfr* 'Chief Steward in Memphis' (A, 2; B, 2; C, 2; D, 3; E, 1; L, 3; M, 12: 25).

Epithets: 'Excellent confidant (*mhy-ib*) of his Lord' (Q); 'one whom the King promoted' (D); 'one beloved of the Lord of the Two Lands' (P); 'he who is in the heart of Horus in his House' (L); 'the eyes of the King of Upper Egypt and the ears of the King of Lower Egypt' (P); 'magistrate at the head of the King's notables' (P); '(one) great [in his rank and exalted in his office]' (P); '[(one) well acquainted] with the way to the Palace' (P); 'the mouth that gives satisfaction in the King's dwelling-place' (P); 'the mouth that gives satisfaction in the entire Land' (L); 'one praised of Ptah every day' (?) (O); 'praised-one, who came forth from the womb praised' (O, Q).

HIS FAMILY

Father: , 'the worthy Haby'² (L).

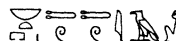
Mother: , 'the House-Mistress, Tjutjuia'³ (L).

Wife: , 'the Chantress of Amūn, the House-Mistress, Mey' (O).

Son: , 'the Fan-bearer on the King's right hand, the King's Scribe, the Chief Steward in the Memphite Nome, Ipy'.⁴

HIS LIFE

His extant monuments do not permit anything like a complete biography of the Chief Steward Amenḥotpe, but it seems desirable as a conclusion to this study to put together the available material and to try to present at least the salient features of his life and activities. Our principal biographical source is the inscription on Statue P, of which Dr. Gardiner has given us a, needless to say, excellent translation.⁵ As a basis of our study we cannot do better than quote (with a few slight alterations) certain portions of this translation. Speaking of himself at the time of the carving and erection of his statue, Amenḥotpe says:

I served the Good God, the [joyful (?)] prince, the King of Upper and Lower Egypt Nibmꜣrꜥ (Amenophis III), when I was young and without kindred (?). When I was grown old and . . . I

¹ See Gauthier, *Dict. géog.*, iv, 130.

² Ranke, *Personennamen*, i, p. 236, 15.

³ *Op. cit.*, p. 395, 25. Note the similarity of this name to that of the mother of Queen Teye.

⁴ See below, p. 24.

⁵ *Ap. Petrie, Tarkhan I and Memphis V*, 33-5.

entered into the Palace when he was in private, so as to behold Horus in this his house,¹ and the nobles walked behind (?). He gave me marks of favour on account of my excellent demeanour, and promoted me [to be] Chief Steward, and my stick was on the heads of the people. I became wealthy in serfs, cattle, and possessions of all kinds without a limit, and [there was nought] to be desired, by the favours of the Lord of the Two Lands Horus Khaemmūet. . . .

He promoted me to direct the constructions in his House of Millions of Years, which he newly made in his cultivated land west of Hetkuptah (Memphis) in the district (?) of 'Ankhtowe (the region of Memphis) . . . (There follows a description of the glories of this temple and of the offerings and personnel which the King provided for it.)

Now behold, I appointed property by written deed out of my fields, my serfs, and my cattle on behalf of the statue of Nibmutrē whose name is . . . which his Majesty [had made] for his father Ptaḥ in this sanctuary. Specification of the same:

Fields, 210½ arouras.

In the Northern Province, fields 220 arouras, of what had been given to me by the favour of the King.

Total, fields [430½] arouras.

[in addition to . . .] . . . 10 . . . 1,000 eḡḡ-laying geese, 1,000 pigs, 1,000 young (?) pigs. His Majesty praised me on account of it, inasmuch as I appeared excellent in his heart.

I attained a venerable age in the favour of the King, and I delivered up (my) bodily frame (?) to the sarcophagus after a lengthy old age; I became united with my tomb [in the Necropolis . . .]. The [respect] of me was with the courtiers, the love of me with all men, and the favour shown me was established in the Palace.

His Majesty gave me divine offerings of that which had come forth from before his processional statue in his House 'United with Ptaḥ' [which he made in his cultivated land west of] Hetkuptah. When moreover the god has sated himself with his possessions and this statue² (also) has received its meals, then provisions shall be caused to go up before this humble servant by the hand of the lector who is in his house, and the *wēb*-priest of the hour shall make offering . . . [according to the] ritual in the course of every day. (There follows a list of the very considerable offerings which the Chief Steward was to receive from the King's endowments.)

Listen, ye *wēb*-priests, lectors (etc.) . . . Do not covet my provisions which my own (?) god decreed for me so as to do me honour at my tomb. I have not made mention of more than my own belongings, I have not demanded aught over and above; forasmuch as I appointed property by written deed for this statue of the King which is in this house in exchange for his giving to me divine offerings that come in and came forth from before his processional statue after the ritual-sacrifice has been made, so as to establish my provisions for future generations to come.

The inscription ends with a lengthy injunction to priests and officials of the future, and the usual protestation of Amenhotpe's virtues.

While Amenhotpe's own statement to the effect that he died and was buried in the reign of Amenophis III naturally cannot be quoted as definitive, there can be little doubt that he did actually fail to survive this King.³ If, on the other hand, he was, as he says, a youth when he entered the service of Amenophis III, he must have died during the last years of the reign. Even so, unless the figures generally accepted for the reign of Amenophis III⁴ are very inaccurate, the Chief Steward cannot have been more than sixty years of age at the time of

¹ Cf. the epithet 'he who is in the heart of Horus in his House', appearing on the Leiden pyramidion (L).

² The statue of the King.

³ That he was not alive in the reign of Akhenaten is indicated by the facts that he was buried at Saḳḳārah, is not mentioned at El-'Amarnah, has no tomb there, and displays no knowledge of the heretic king or his heresy. Amenhotpe's son, Ipy, may well be the owner of a tomb at El-'Amarnah (see below), but by the time this tomb was made the father of its owner would, normally, have been dead for many years.

⁴ 1411-1375 B.C. (Breasted, *Hist.*, 599), or 1405-1370 B.C. (Meyer, *Gesch. Alt.*, 2nd ed., vol. II, pt. 1, p. 149).

his death. He must therefore have been born during the second quarter of the reign of Amenophis II, and we can safely place his span of life within the years 1440 and 1370 B.C.

As was usual in ancient Egypt, Amenhotpe appears to have achieved his exalted rank on his own merits. His parents were clearly very ordinary people, perhaps peasants. They were not, at all events, members of the official class, and the utmost which he was able to summon up for them in the way of titles were those which we might best translate as 'Mr.' and 'Mrs.' (*sꜥb* and *nbt-pr*).

There can be little doubt that their son started his career as a scribe, and that his earliest title was that of plain 'Scribe'. His proficiency earned him a position in the royal administration, and he became a 'King's Scribe', a title which he bore until the end of his life, rising at length to become 'the Veritable Scribe of the King', or 'the King's own Scribe', *i.e.*, one of Amenophis III's personal secretaries.

As 'King's Scribe of the Recruits' he was held responsible for the feeding, clothing, and general management and organization of bodies of soldiers or workmen. The profession of scribe might require, as we know, the ability to keep accounts, to solve complicated mathematical and mechanical problems, and to plan and oversee the execution of architectural projects.¹ It was therefore natural that Amenhotpe, probably early in his official life, should have added to his functions those of steward, treasurer, and architect.

It was as a steward that he reached the pinnacle of his career, and when he became the King's Chief Steward in the great city of Memphis his power and wealth were probably the equals of those of any official in the country, excepting always his great contemporary and namesake, the son of Hapu.

Amenhotpe's activities as a treasurer seem to have been incidental to his functions as a steward. The traditional and probably purely honorary title *sdꜥwtꜥ bity* may be discounted altogether, since it is borne by almost every Eighteenth-Dynasty official of any prominence. The significance of the title 'Overseer of the Houses of Silver and Gold' is also questionable. It appears, at all events, only once on Amenhotpe's monuments—on his British Museum statue (Q). The same applies to the common title 'Overseer of the Double Granary in the entire Land', which occurs on the Leiden pyramidion (L) in the midst of a long series of traditional titles and epithets.

The accomplishments of Amenhotpe as an architect, on the other hand, cannot be doubted. As 'Controller of Works' and 'Overseer of Works in "Khenmet-Ptah"' he built Amenophis III's temple at Memphis, and was probably responsible for that king's additions to the Eighteenth-Dynasty temple at Abydos.² Though certainly not as large or elaborate as the Pharaoh's principal temple at Thebes, built for him by Amenhotpe, son of Hapu, there is no reason to doubt that the temple at Memphis was, as its builder affirms, an important and magnificent structure.

As a prominent citizen of his town Amenhotpe naturally took part in the local religious activities. He was Overseer of Priests in the temple of the goddess Sakhmet, consort of Ptah and the principal female divinity of Memphis, and served also as a priest of another lioness-headed deity, the local goddess Weret-ḥekau. He appears, moreover, to have been charged with the supervision of all religious festivals held at Memphis, particularly that of the chief god, Ptah. His priestly offices should not, however, be taken too seriously, and are probably to be grouped with the score or so other, largely honorary, titles, which, like our modern orders and decorations, were showered upon every eminent man in recognition of his services in his special field.

¹ *Pap. Anastasy I*. See also Winlock, in *Bull. MMA* 18, October, pt. ii, 6.

² See above, p. 19.

It is not difficult to believe the Chief Steward Amenhotpe when he tells us that he frequented the palace and was on familiar terms with the King. The relations existing between the Pharaoh and his business manager are nowhere so well illustrated as in the mutually beneficial agreement which the two men drew up regarding the offerings to be supplied to their respective statues (see above, p. 21).¹ This was evidently neither a commandeering of property on the part of the King, nor a concession to his sovereign on the part of the Steward, but a strictly business transaction, as between equals, based on the principle of value returned for value received.

From the description of the transaction on the Oxford statue we obtain a very clear insight into the astounding wealth of our Memphite official. A man who, in a country like Egypt, could devote the produce of 430 arouras of land to the upkeep of a single statue must have ranked high among the nation's property-holders.

The outstanding fact which we learn concerning the Chief Steward Amenhotpe is that he was, first and last, a Memphite, with his life, his activities, and his interests centred in the city of Memphis. He held his highest offices in Memphis, was buried there, and almost certainly received his early training there. His religious affiliations were throughout with the gods of Lower Egypt and of the Memphite region in particular. The name of Amūn is conspicuously absent from his monuments,² as are also the names of other Theban and Upper-Egyptian gods.

Those of us who have come to regard the Eighteenth Dynasty as a purely Theban phenomenon may find it difficult to believe that an official of this dynasty could have risen to importance without leaving his mark in the capital city; and the fact that the achievements of Amenhotpe were confined almost entirely to Memphis may tend to mark him in our estimation as a provincial of no real standing. Nothing could be more fallacious. In the Eighteenth Dynasty Memphis, though no longer the capital, seems nevertheless to have remained the largest and from many points of view the most important city in Egypt.³ Owing to its more temperate climate and the fact that it occupied a central position in the Egyptian empire, it is probable that the Eighteenth and Nineteenth Dynasty Pharaohs spent more of their time there than in their recently established capital and cult centre in southern Egypt. It is likely that, far from feeling subservient to Thebes, the inhabitants of the proud and ancient metropolis, the affairs of which were for a while largely in the hands of the Chief Steward Amenhotpe, actually looked down upon the 'Southern City' as an upstart.

Having started life as the son of a commoner and having entered the service of the King, as he tells us, 'without kindred'—that is, without the advantages which a wealthy and powerful family could have bestowed on him—Amenhotpe at the time of his death had so smoothed the way for his own son, Ipy, that the latter was able to step forthwith into the important office which his father had vacated. Thus we see an Egyptian family rising in one generation from obscurity to a point where its members were acceptable candidates for the

¹ This transaction is discussed by Dr. Gardiner, *ap. Petrie, Tarkhan I and Memphis V*, 36.

² His own name, Amenhotpe, was probably taken directly from that of the king in whose reign our Memphite official was born, namely Amenophis (Amenhotpe) II, and had no conscious association with the Theban god.

The fact that Amenhotpe's wife, Mey, bore the title 'Chantress of Amūn' may indicate that she was a Theban, but this is highly conjectural.

The only other mention of the god Amūn on the Chief Steward's monuments occurs in a more or less extraneous 'aside' in line 21 of the inscription on the Oxford statue.

³ See Winlock in *Bull. MMA* 18, October, pt. ii, 10-11.

highest public offices. Since, however, a hereditary aristocracy was, as a general rule, unknown in ancient Egypt, we cannot doubt that Ipy was himself a man of considerable ability and had been given his father's office principally on the basis of his own qualifications. The data which we possess regarding this son of Amenhotpe are, in any case, worth some brief notice, if only as a means of rounding off our knowledge of Amenhotpe himself.

HIS SON, THE CHIEF STEWARD IPY

It is probable that Ipy took over his father's office as Chief Steward before the latter's death, for on the stela which he erected in Amenhotpe's tomb he already bears the title. On this stela (E) the two Chief Stewards, father and son, appear, seated face to face as equals, their figures being practically identical. Like that of Amenhotpe,¹ Ipy's name in the inscriptions is accompanied by the epithet *msc-hrw*. It is therefore evident that, as Bagnani² has pointed out, the stela was intended as a memorial not only to Ipy's father, but to Ipy himself.

Ipy's titles are 'Fan-bearer on the King's Right', 'King's Scribe', 'Chief Steward', 'Chief Steward of Memphis', and 'Chief Steward in the Memphite Nome'.³ In addition to the monuments discussed below, he is the owner of a stela in the Ermitage Museum at Leningrad.⁴



That he is to be identified with the owner of one of the smaller tombs at El-'Amarnah⁵ is open to question.⁶ The titles of the owner of the tomb ('King's Scribe', 'Overseer of Soldiers', 'Steward') do not match those on the Florence and Leningrad stelae sufficiently well to make the identification certain. On the other hand, it is reasonably sure that the son of Amenhotpe lived during the reign of Akhenaten. If he continued to flourish in this reign, it is not unlikely that he joined the heretic king at El-'Amarnah, and he may well have prepared a tomb there.

Ipy appears, however, to have been actually buried at Saqqārah in a tomb situated not far from that of his father. In this tomb were found two alabaster canopic jars, inscribed with his name and titles. Like the pyramidion (L) and the canopic chest (M) of Ipy's father, they were discovered by Anastasy between the years 1820 and 1826 and are at present in the Rijksmuseum at Leiden.⁷

The fact that Ipy was buried at Saqqārah does not preclude the possibility that he may have also made the tomb at El-'Amārnah and never occupied it. It is highly probable that he died at Memphis in the time of Tutankhamūn, Ay, or Haremhab.

¹ More frequently on this monument called Huy.

² *Aeg.* 14, 38.

³ That the last title indicates an expansion of the powers exercised by Amenhotpe is doubtful. The designations  and  were probably interchangeable, and we should perhaps be forcing a point if we attempted to see in them a strict differentiation between the city of Memphis and the nome.

⁴ Lieblein, *Die aegyptischen Denkmäler in St. Petersburg, Helsingfors, Upsala und Copenhagen*, No. 45, p. 27, Pl. v, 17; *Dict. des noms hiérog.*, *Supplément*, No. 2053, p. 791.

⁵ Bouriant, *Deux jours de fouilles à Tell el Amarna*, *Mém. Miss. fr.* I, 15; Bouriant, Legrain and Jéquier, *Les Tombes de Khouitatonou. Monuments pour servir à l'étude du culte d'Atonou en Égypte*, I (*Mém. Inst. fr.*, VIII), 87-92; Davies, *Rock Tombs of El Amarna*, IV, pp. 19-20, Pls. xxx-xxxiii.

⁶ Schiaparelli, *Antichità egizie* (see p. 11, under E), p. 351.

⁷ Wijngaarden, *Lijkvazen en Lijkvazenkisten. Beschrijving van de egyptische Verzameling in het Rijksmuseum van Oudheden te Leiden*, Deel XIII, pp. 13-14, Pl. xi, nos. 70, 71. Jars 69 and 72, which Wijngaarden has grouped with them, are the property of a different person.



1

Biographical Inscription of
Nekhebu at Boston.

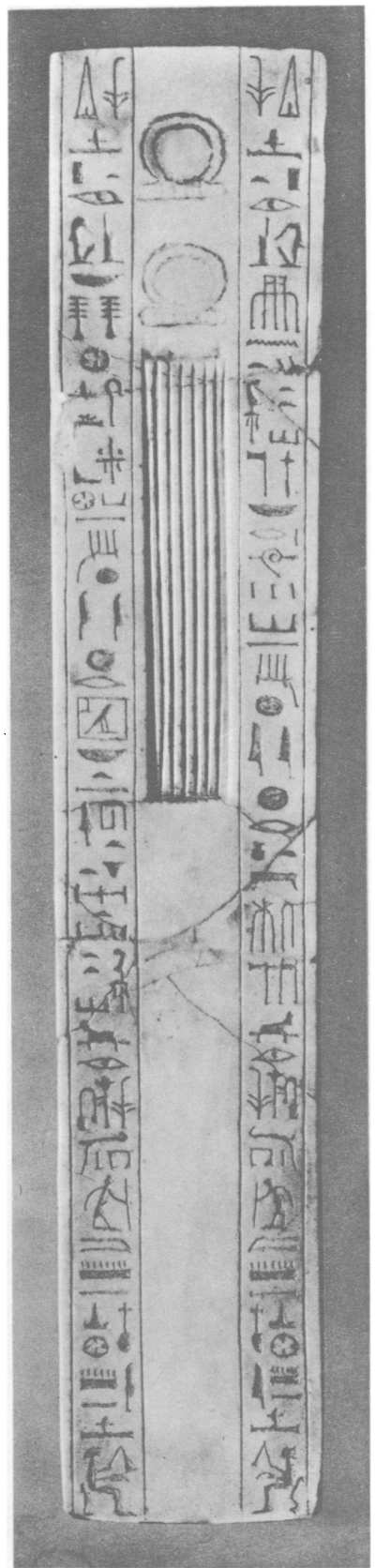

2

Writing-palette of the Chief
Steward Amenhotpe.

SOME REPRESENTATIONS OF TOMBS FROM THE THEBAN NECROPOLIS

BY NINA M. DAVIES

At the present day the exterior of no tomb-chapel dedicated to the nobles in the Theban Necropolis preserves its original aspect, but sufficient evidence for reconstruction of the architectural features is sometimes to be found in the courtyards. Within, on the tomb-walls—especially those dating from the end of the Eighteenth Dynasty onwards—a number of representations of mortuary chapels are to be seen. Whether these give a real picture of what the building looked like or envisage the ideal in the artist's mind, is a subject too large to discuss here. A few salient parallels are, however, mentioned below.

The tomb-pictures collected are chiefly from Shēkh 'Abd el-Ḳurnah, El-Khōkhah, Dirā' Abū 'n-Naga, and Ḳurnet Mur'ai. Only two typical ones from Dēr el-Medīnah out of a large number in that district have been selected, and these only for purposes of comparison with types in the four former districts.

Vignettes of the Book of the Dead often show tomb-chapels, and these are also to be found illustrated on stelae. None of these is included here.¹

In the course of his excavations for the Institut français at Dēr el-Medīnah, M. Bruyère has found sufficient evidence to enable him to reconstruct a small chapel which permits us to visualize one of the types as it appeared in reality. Although dating from the end of the Eighteenth Dynasty this building corresponds very closely to many of the pictures in the neighbouring tombs of the Nineteenth (see Figs. 19, 20).² The beginning of the Eighteenth Dynasty provides us with little architectural variety. The pictured tomb is shown as merely a door with its framing and cornice above, placed on a platform or threshold (Fig. 1). Towards the end of the Eighteenth Dynasty the pyramid appears (Fig. 4), and there is often a string-course of cones below the cornice.³ In the Nineteenth Dynasty the small pyramid above the building is almost invariable unless replaced by a free-standing pyramid at the side (Figs. 7, 15).

The actual fragments found by M. Bruyère prove that these pyramids were common in Dēr el-Medīnah.⁴ On the lower slopes of Shēkh 'Abd el-Ḳurnah there exist no traces of them to-day, although they are usually shown in the later tomb-representations. There is, however, a pyramid in El-'Asāsif which may belong to the large Saite tombs in the neighbourhood. At Dirā' Abū 'n-Naga a series of late brick pyramids on the upper terraces

¹ Two from papyri and one from a stela are reproduced in Bruyère, *Rapport sur les Fouilles de Deir el Médineh* for 1924-5 (1926), p. 9. (In this and similar references below to M. Bruyère's *Rapports*, the years in brackets are those of publication.)

² Bruyère, *op. cit.* for 1927 (1928), pp. 118, 119. The types of chapels and their component parts at Dēr el-Medīnah are dealt with in these publications of the Institut Français, particularly in the *Rapport* for 1923-4 (1925), pp. 5-18.

³ For evidence of the use of cones as tomb-decoration see Winlock, *Bull. MMA*, Feb. 1928, *The Egyptian Expedition 1925-1927*, p. 6. Cones are shown on reconstructed buildings by Borchardt, Königsberger, and Ricke, in *ZÄS* 70, 29.

⁴ Bruyère, *Rapports* for 1928 (1929), p. 95, Fig. 53, and for 1923-4 (1925), Pl. vii.

may well be the origin of those depicted in the tombs just below (Figs. 14, 15).¹ The point of the pictured pyramid is painted black, or sometimes blue (Fig. 8). The actual apex stones found at Dēr el-Medīnah are of limestone, and are sculptured with a figure adoring and prayers to the solar deities.² A small niche or open recess half-way down the pyramid which was found in the same necropolis, and which there is reason to believe contained a kneeling figure in relief behind a stela,³ has its pictured counterpart in the form of a face looking out at the spectator from over the top of the painted stela, as if the man were holding it before him (Figs. 10, 9).

Remains of colonnaded façades are not unknown outside Eighteenth-Dynasty tombs, but, so far as we know, are not represented on the walls at this period, although fairly common in the Nineteenth (Figs. 7, 13, 15).

Stelae are frequently found during the excavation of courtyards, or are sculptured on the dressed wall of rock outside tombs as well as in the interiors. These are often pictured (Figs. 6, 7, 8, 10, 11). In tombs Nos. 13 and 273 the mummy is placed before a stela alone, and no mortuary chapel is shown.

From the reign of Amenophis III onwards the usual place for the picture of the tomb is at the end of the long funeral procession, at the point when the mummy has been taken from the catafalque and placed upright in front of the chapel, with tall bouquets before and behind it. Mourning-women embrace it, and either a male mourner, or a priest personifying Anubis, supports it. On the other side of the tomb the sloping line of the desert hill, which the inner chambers are to be thought of as penetrating, is nearly always shown. Out of this comes the Goddess of the West, usually a woman, but sometimes represented by a Hathor-cow (tombs Nos. 296, 19, 341, 30). The Goddess stretches out her arms and receives the deceased, who has meantime shed his mummy-cartonnage and emerged from it as from a chrysalis. He is now clothed like a living being again, and enters into the life and experience of the land beyond the grave to which the tomb-door is the entrance (Fig. 7).⁴

These pictures may be roughly classified into the following groups:

A. A simple corniced door-framing with a door in the centre. Sometimes there is a string-course of cones under the cornice (Figs. 1, 3).

B. Similar to A, but with a pyramid on the top, and occasionally pillars flanking the door. A stela is often placed in front (Figs. 4, 5, 10, 11, 12, 14, 16, 17, 18, 22).

C. A corniced building with a pyramid on the top, a portico at the side, and a stela (Figs. 6, 8).

D. A colonnade with a free-standing pyramid at the side, in which is a doorway, above a corniced platform forming the base on which the pyramid rests (Figs. 7, 15).

For a rare example of a pyramid on a plinth without a door or colonnade see N. de G. Davies, *Two Ramesside Tombs*, Pl. xiii and p. 27.

I have to thank Mlle Baud for permission to reproduce Figs. 6 and 23, and M. Bruyère for Figs. 19 and 20.

¹ Tomb No. 35, of Bekenkhons, in this district has a pyramid belonging to it, and so also has tomb No. 288.

² Bruyère, *Rapport for 1922-3* (1924), Pls. xv, xci.

³ See Bruyère, *Rapport for 1923-4* (1925), pp. 12, 14, for a discussion of the whole subject, and Pl. xxx for a restoration of these *lucarnes*.

⁴ For an exception, where the Goddess greets the deceased *before* he enters the tomb, see N. M. Davies, *Two Ramesside Tombs*, Pl. xiii.

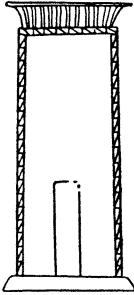

FIG. 1. (1:8)

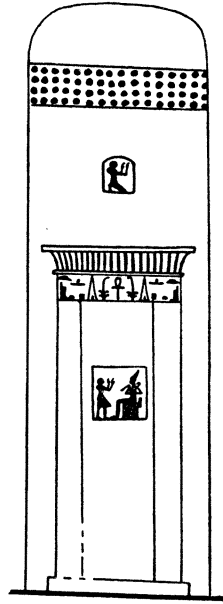

FIG. 2. (2:9)

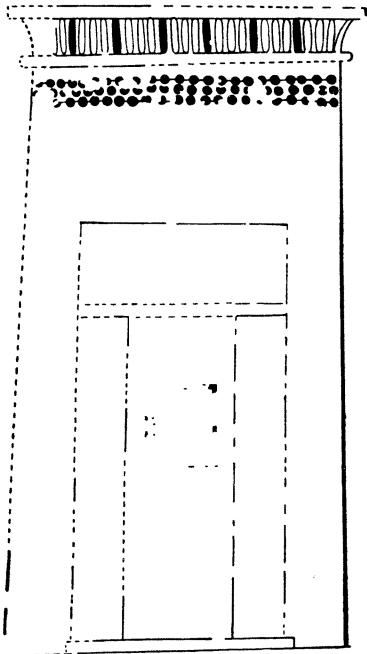

FIG. 3. (1:8)

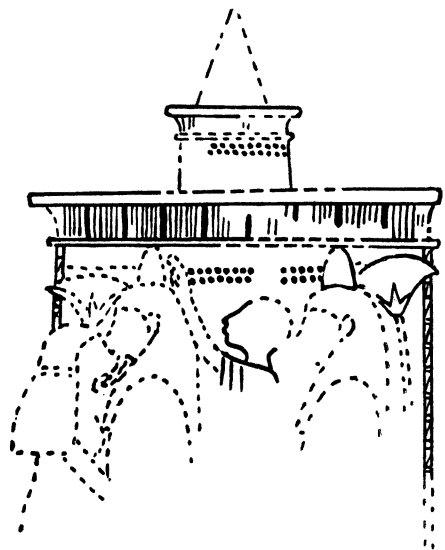

FIG. 4. (1:5)

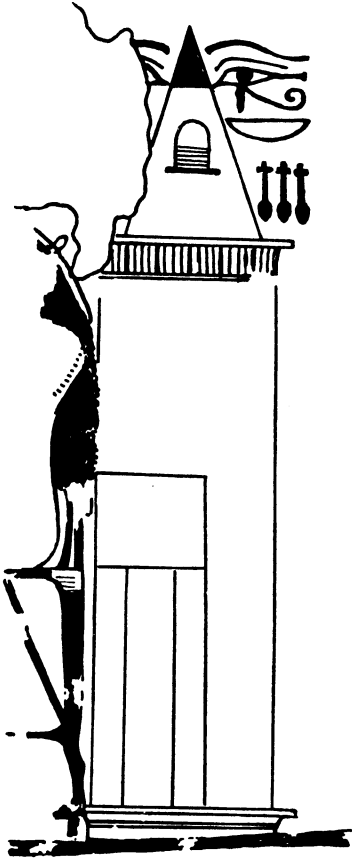

FIG. 5. (1:5)

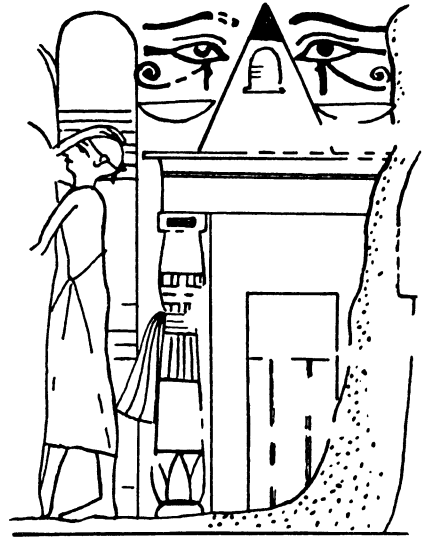

FIG. 6. (1:5)

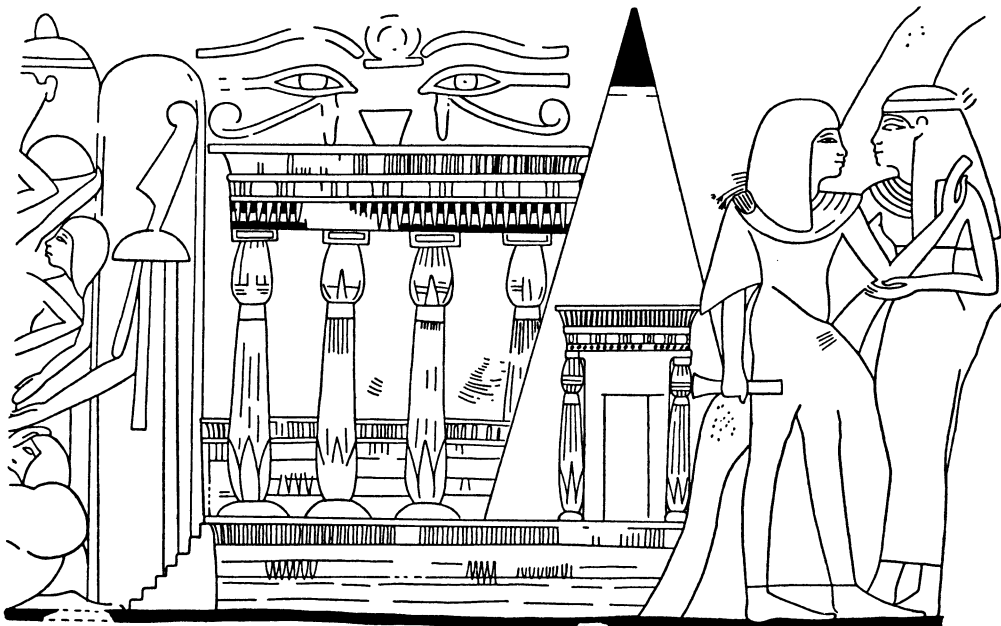

FIG. 7. (1:6)

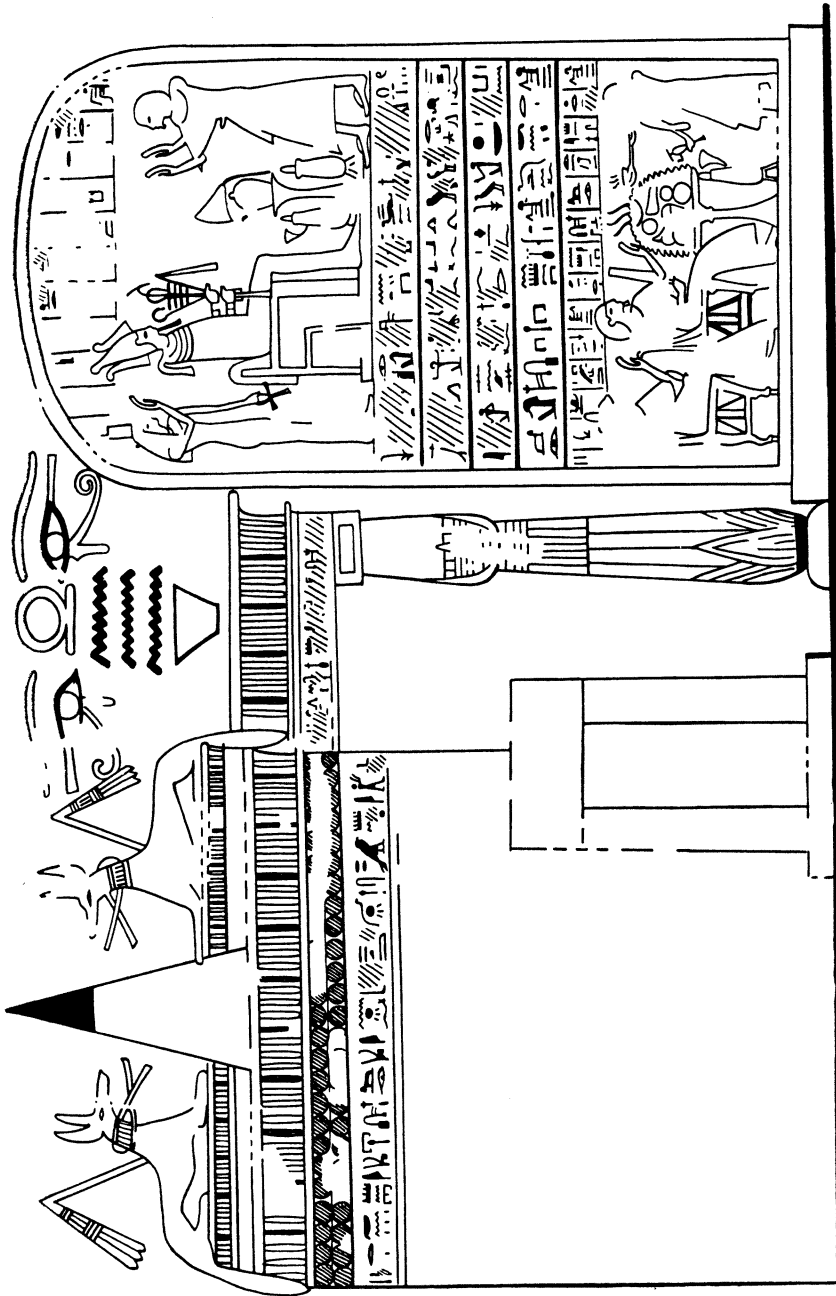

FIG. 8. (1:4)

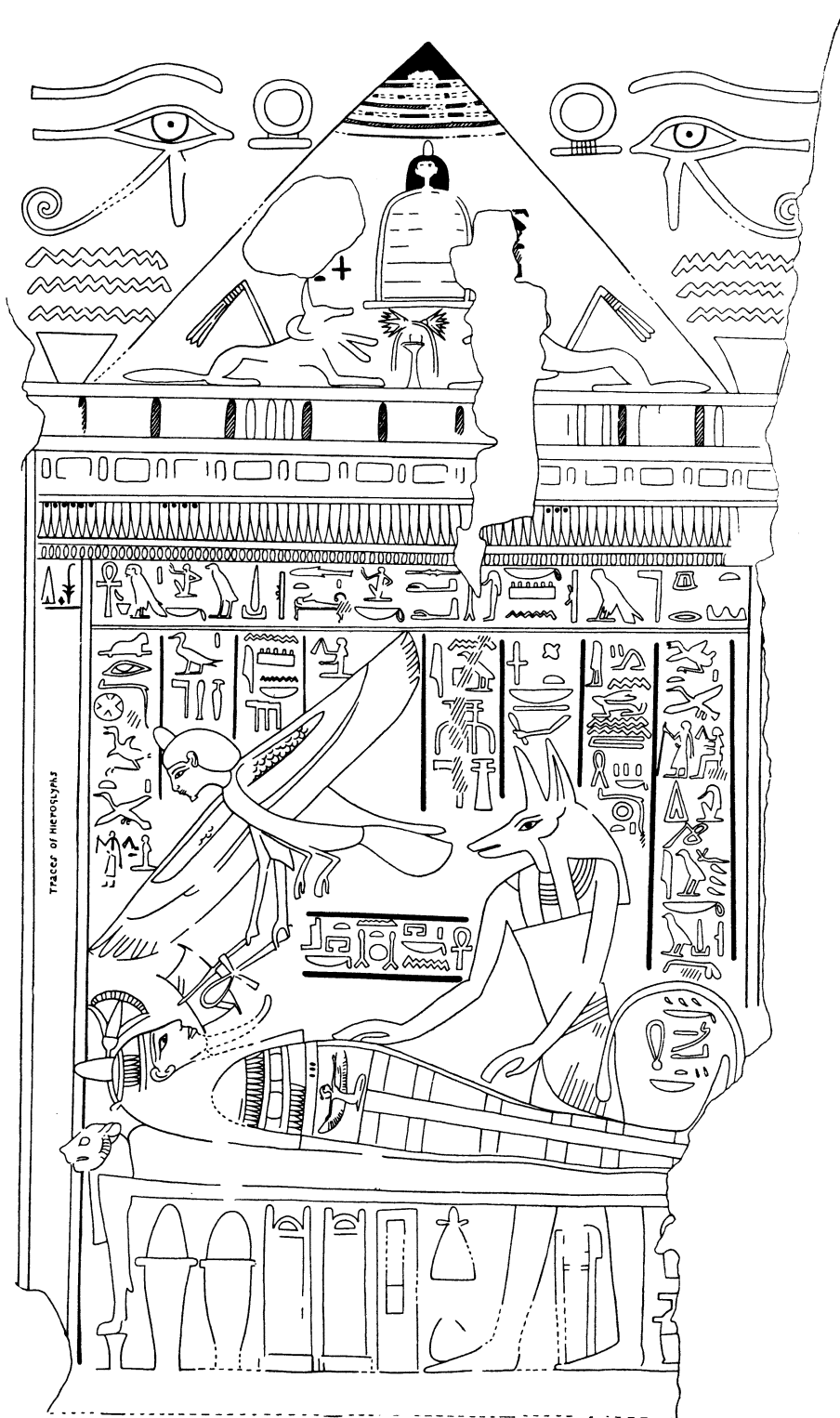

FIG. 9. (1:7)

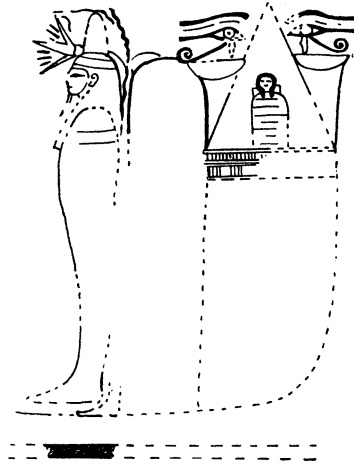

FIG. 10. (1:9)

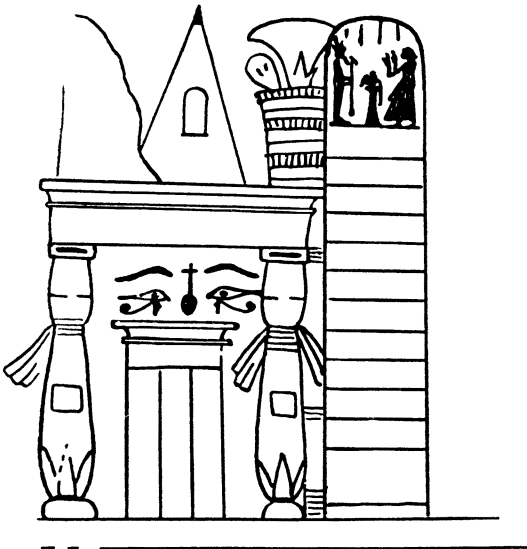

FIG. 11. (1:8)

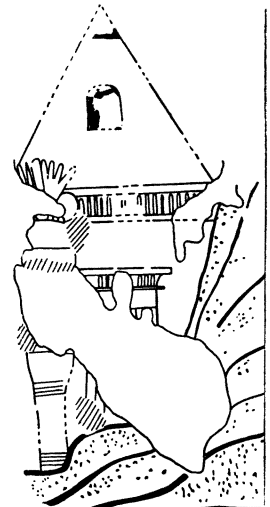

FIG. 12. (1:6)

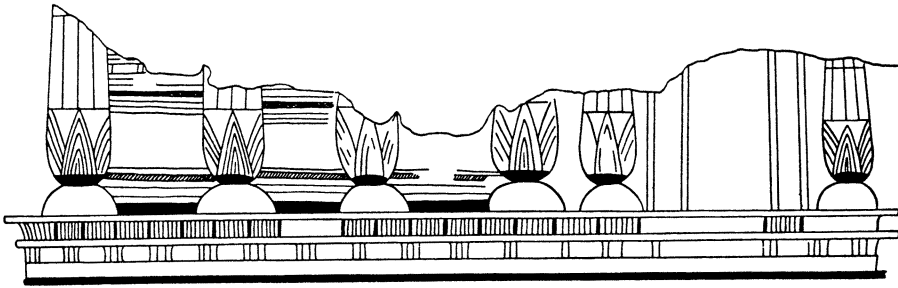

FIG. 13. (1:6)

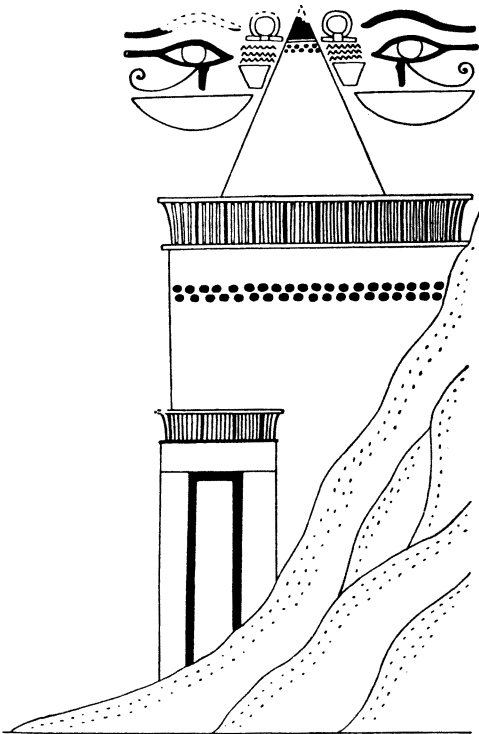

FIG. 14. (1:5)

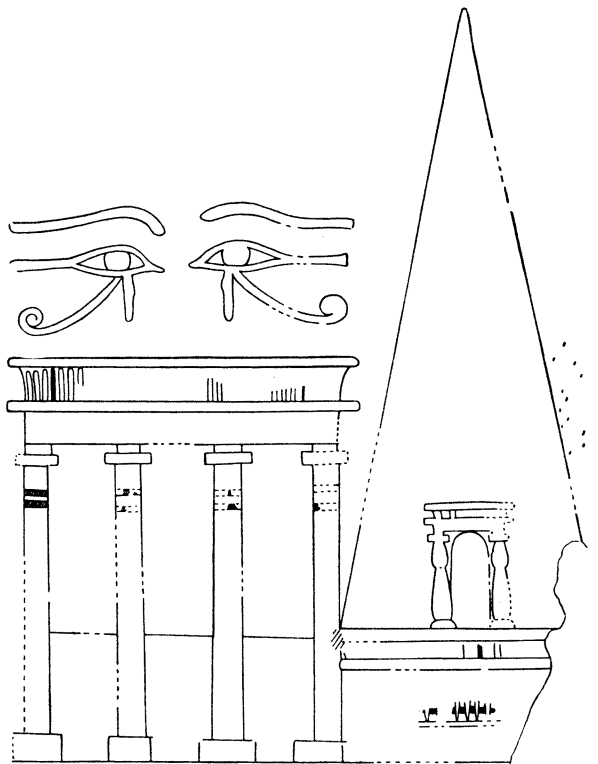

FIG. 15. (1:7)

(33)

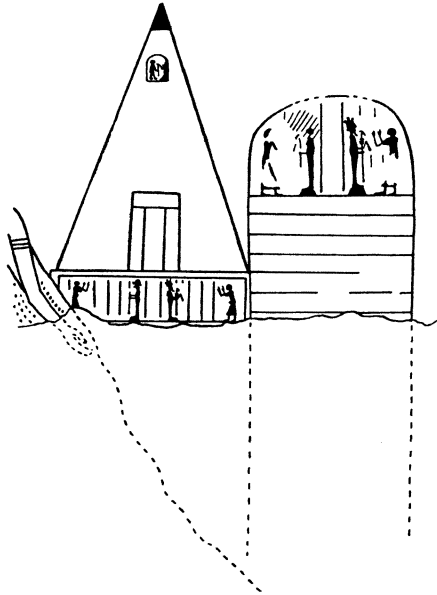

FIG. 16. (1:5)

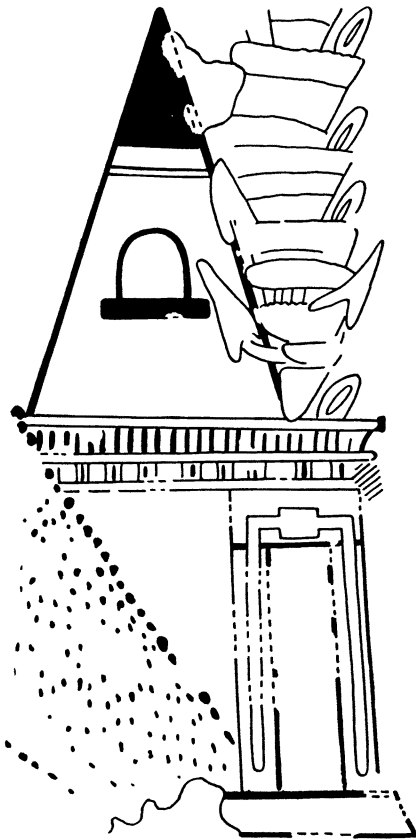

FIG. 17. (1:4)

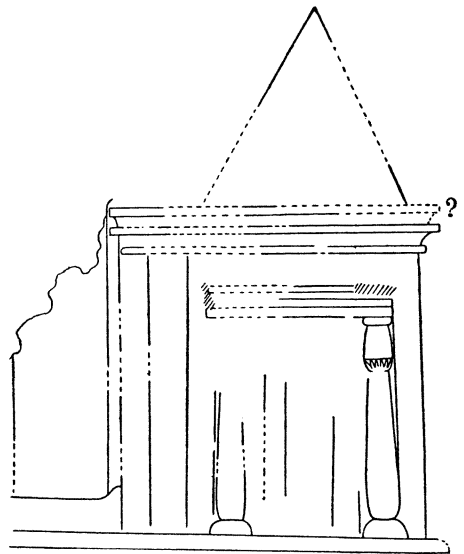

FIG. 18. (1:8)

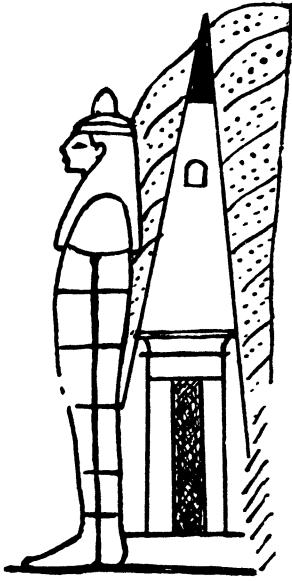

FIG. 19.

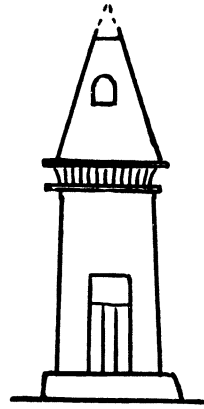

FIG. 20.

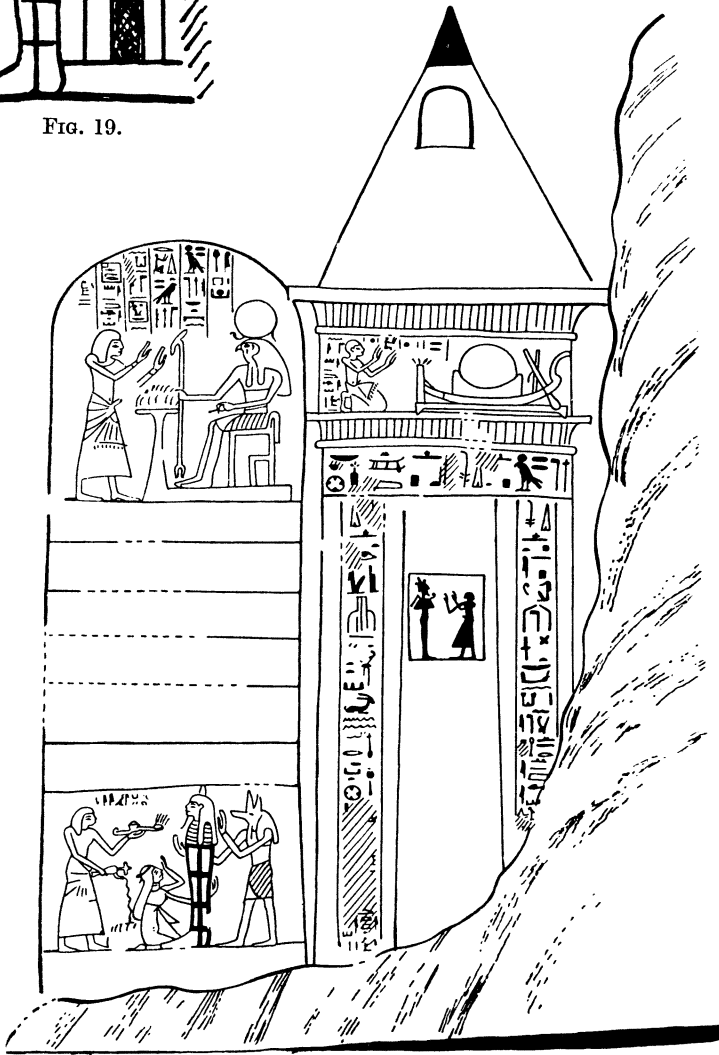

FIG. 21. (1:5)

(35)

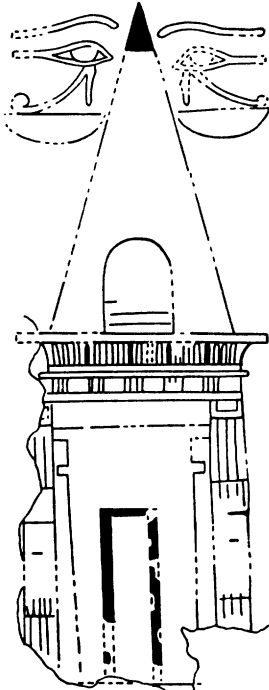

FIG. 22. (1:6)



FIG. 23.

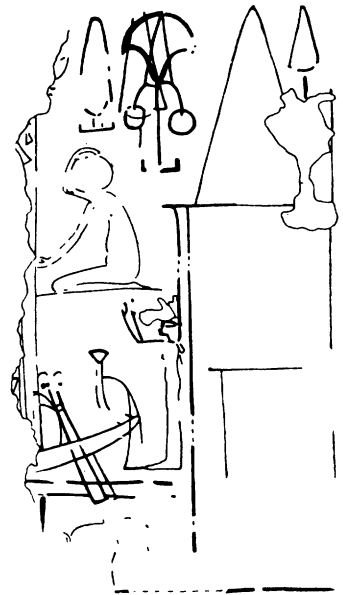

FIG. 24. (1:7)

DESCRIPTION OF THE FIGURES

Fig. 1. Tomb of Amenemhēt, No. 82. Tuthmosis III. Shēkh 'Abd el-Ḳurnah. Publ. Davies-Gardiner, *The Tomb of Amenemhēt*, Pl. x.

This is a typical tomb-façade, imitating a false door (or here perhaps a shrine). It is very similar in form to Figs. 3, 4, and 20, but lacks the pyramid of the two latter. The funeral procession leads up to it, but no mummy is placed before it at this period. The Goddess of the West stands behind, and a priest holding a leg of beef kneels before it. For the same torus-moulding on the façade see Fig. 4.

Fig. 2. Tomb of Nebamūn and Ipuky, No. 181. Amenophis III. El-Khōkhah. Publ. N. M. Davies, *The Tomb of Two Sculptors at Thebes*, Pls. xix, xxi.

Some confusion seems to have arisen between the tomb and the stela. The latter is decorated with cones, which ought really to be shown below the cornice surmounting the building, while the stela should be separate. The Falcon of the West, replacing the goddess, is placed behind the tomb, while two mummies are in front. Exactly the same picture is shown directly below. Here booths are placed in front of the chapel, and mourners greet the boats bringing funerary equipment towards it. No other example of this type is known to me.¹

Fig. 3. Tomb of Raḥmose, No. 55. Amenophis III-Akhenaten. Shēkh 'Abd el-Ḳurnah. See Porter-Moss, *Top. Bibl.*, 1, 84, 86 (at 4 in plan).

A string-course of cones is below the cornice. The conventional figure of the Goddess of the West stands on a mound of sand behind the tomb. Two mummies in front are being purified and mourned. The burial-pit is just below the picture.²

Fig. 4. Tomb of Neferhotep, No. 49. Ay. El-Khōkhah. Publ. N. M. Davies, *The Tomb of Nefer-hotep*, Pl. xxiv.

This seems to be the earliest representation of a pyramid placed on top of the mortuary chapel. Rows of cones appear on the pyramid, and also on the lower part of the building. A second version of the tomb, without a pyramid and similar in form to that from Raḥmose (Fig. 3), is depicted on another wall (*op. cit.*, Pl. xx). For another example of two differing structures in the same chapel see Figs. 5 and 6.

Figs. 5 and 6. Tomb of Amenmose, No. 19. Ramesses I-Sethōs I (?). Dirā' Abū 'n-Naga. Publ. G. Foucart, *Le tombeau d'Amonmos, 4^e partie*, Pls. ix, xxvi.

Two versions of the mortuary chapel are shown in this tomb. The one with the portico (Fig. 6) has the mummies in front. At the back of the building the deceased persons advance against the desert cliff-side towards the Hathor-cow of Dēr el-Baḥri. The stela shows Osiris worshipped by Amenmose and has a text below. In the other example (Fig. 5), no portico, stela, or desert is apparent. It is evident that here the seated figures of Amenmose and his wife are placed outside the tomb, the columns of which may perhaps be hidden by their chairs. The structure is raised on a plinth surmounted by a cornice.

Fig. 7. Tomb of Amenemōpet, No. 41. Ramesses I-Sethos I (?). Shēkh 'Abd el-Ḳurnah. See Porter-Moss, *op. cit.*, 1, 74 (at 2 in plan).

This picture is of the same type as Fig. 15, but the pyramid at the side projects in front of the colonnade although apparently standing on the same corniced plinth. A screen-wall is between the columns, and above are curving lines in red paint the meaning of

¹ For a suggested reconstruction see Borchardt, Königsberger, and Rieke, *ZÄS* 70, 29, Abb. 7.

² For a similar building of this type see N. M. Davies, *The Tomb of Nefer-hotep*, Pl. xx.

which is obscure. Steps lead up to the top of the platform—a feature not met with in the other examples. The symbol of the West against the stela has an outstretched arm which helps to support the mummy. On the right, against the desert cliff, Hathor embraces the deceased when he has emerged from the tomb. The picture is in coloured relief, with details in paint only.

Fig. 8. Tomb of Neferronpet, also called Kel ('Kenro'), No. 178. Ramesses II. El-Khōkhah. To the right of the entrance to the second chamber. Publ. Borchardt and others, *ZÄS* 70, 28, Abb. 3.

As the picture is at the end of the wall there is no room to show the desert. The Anubis dogs on their shrines are to be thought of perhaps as wooden pieces placed on the top of the building, and not as forming an integral part of the architecture. The two rows of cones beneath the cornice are as usual red, the figures on the stela dark blue, while all the hieroglyphs are black. The apex of the pyramid is here blue. Two mummies stand before the stela.

Fig. 9. Tomb of Pesiūr, No. 106. Sethōs I-Ramesses II. Shēkh 'Abd el-Ḳurnah. See Porter-Moss, *op. cit.*, I, 132, 134 (at 15 in plan).

This scene, hitherto published incompletely, clearly represents the interior of a tomb. The pyramid above, the cornice (the modelled end of which can be traced bordering the right-hand break), and the stela or niche surmounted by a head as in Fig. 10, leave little doubt as to the correctness of this interpretation, which is further supported by the fact that there is no other picture of a tomb-structure on the walls. The point of the pyramid is black with alternate red and black bands below it. The polychrome hieroglyphs are incised except those on the left-hand column, which are in black paint, and those on the pyramid, which are in blue paint.

Fig. 10. Tomb of Nakhtamūn, No. 341. Ramesses II. Shēkh 'Abd el-Ḳurnah. On the south-west wall.

The lower portion of the picture is damaged, and only the upper parts of the corniced building with its pyramid, and the stela in front with the back of the mummy against it, can now be seen. There was probably a door in the middle of the façade. The little stela on top of the cornice with the full-face framed in a wig appearing above it is paralleled in Fig. 9. At the bottom the foot of a man holding the mummy is indicated.

Fig. 11. Tomb of Khons, No. 31. Ramesses II. Shēkh 'Abd el-Ḳurnah. See Porter-Moss, *op. cit.*, I, 64, 66 (at 6 in plan).

The building represented has a columned portico and a corniced doorway, above which the sacred eyes and *nefer*-sign, usually shown apart from the building itself, are incorporated in the decoration. Streamers hang from beneath the capitals. A *hetep-di-nesu* prayer is inscribed on the stela, but is here omitted in the drawing. The line of the desert appears to intervene between the portico and the pyramid, as if the latter were a separate building, but this may be due to lack of space, since the corner cramps the drawing on the left. Two mummies stand before the stela, which is flanked on either side by a tall bouquet.

Fig. 12. Tomb of Nedjemger, No. 138. Ramesses II. Shēkh 'Abd el-Ḳurnah. On the south-west wall.

On the left a large bouquet behind a mummy interferes with the outline of the tomb. To the right the desert ends where it meets the edge of the wall. The stela (or niche), half-way down the pyramid, is apparently of solid colour like the point.

Fig. 13. Tomb of Tjoy, No. 23. Merneptah. Shēkh 'Abd el-Ḳurnah. See Porter-Moss, *op. cit.*, I, 60, 68 (at 7 in plan).

The sculptured representation now has all its details in paint so thickly overlaid with varnish that the decoration on the screen-wall between the columns is not easy to make out. What must have been one of the most elaborate pictures of tomb architecture at Thebes is so much destroyed that it is impossible to say whether a pyramid formed part of the design or not. There is scarcely room for it on the right as in Fig. 15. On this side the deceased is received by Hathor, but only the feet of the figures are extant. On either side of what seems to be the doorway the name and titles of Tjoy are inscribed in small painted hieroglyphs (omitted in drawing). The actual courtyard of this tomb shows five round columns along the north and south sides, and two square pillars on either side of the entrance, in part raised on a low corniced platform. These features are perhaps reflected in the picture.

Fig. 14. Tomb of Raya, No. 159. Merneptah. Dirā' Abū 'n-Naga. On the south wall. Publ. Borchardt and others, *ZÄS* 70, 28, Abb. 1.

As the scene extends to the limit of the wall there is no room for the reception of the deceased by the Goddess of the West, and the desert comes down past the chapel door. The double row of cones on the pyramid as well as below the cornice is also found in Fig. 4, but here the first row is just beneath the apex. A bouquet rests against the left of the building behind two mummies which stand on a platform. A burial-pit exists below the picture, as in tombs Nos. 55 and 41.

Fig. 15. Tomb of Tjonūfer, No. 158. Merneptah (?). Dirā' Abū 'n-Naga. On the west wall of the first room, to the left of a pair of seated statues.

The columned door of the free-standing pyramid is placed on top of a corniced plinth as in Fig. 7, but whether the entrance is an open archway or represents a stela in front it is difficult to determine.¹ The pillars have flat capitals and rectangular bases. Two bands of red paint decorate the upper parts, while a screen-wall runs between them. Some pebbles, traces of the hill-side, appear on the extreme right, and two mummies are on the left. The picture is sculptured in low relief with details in paint. Outside, in the courtyard of the chapel itself, bases of pillars still exist, while on the slope above tomb No. 158 brick pyramids can be seen.

Fig. 16. Tomb of Ḥori, No. 259. Ramesside. In the plain north of the Ramesseum. On the north wall.

In the picture a door is curiously placed high up on the face of the pyramid. Before the gods depicted under the pyramid and on the stela are inscriptions too minutely written to be reproduced in the drawing; they consist of the name and titles of the deceased and prayers to Rēc-Ḥarakhte. Behind the tomb the Goddess of the West in the cliff stretches out her arms, but Ḥori has not yet passed through his tomb. The bottom of the picture has been destroyed, but the height from the top of the pyramid to the base-line is approximately sixteen inches.

Fig. 17. Tomb of Nefersekeru, No. 296. Ramesside. El-Khōkhah. See Porter-Moss, *op. cit.*, I, 164, 167 (at 8 in plan).

A large bouquet on the right of the picture (behind the mummy), and the line of the desert on the left (from which the head of a Hathor-cow emerges), interfere with the outline of the building. The door, painted yellow, is surrounded by a curious border widening into

¹ For the reconstruction of a similar door based on actual features found outside tomb No. 288/9 see Borchardt and others, *ZÄS* 70, 29, Abb. 6.

a rectangle above, all of which is coloured blue; this represents the line of text with a pictured panel in the centre. The drawing is very rough.

Fig. 18. Tomb of Saroy, No. 233. Ramesside. Dirā' Abū 'n-Naga (lies open). On the south wall.

The pyramid here is not in the centre of the façade. Two mummies stand against the stela in front, the top of which is destroyed. It is placed on a mound of sand, or has a shaped base. The Goddess of the West receives Saroy and his wife on the farther side of the tomb. The sculptured surface of the wall was once painted, but the only traces of colour now visible are on the capital of the column. The restorations in dotted lines are tentative.

Fig. 19. Tomb of Nakhtamūn, No. 335. Ramesside. Dēr el-Medīnah. On the west wall. Publ. Bruyère, *Rapport* for 1924-5 (1926), Fig. 80, *salle* A (photograph).

This tomb pictures a type not uncommon at Dēr el-Medīnah. It consists of a sharply pointed pyramid with a doorway filling the greater part of the space below, the whole raised on a low platform (compare with the free-standing pyramids in Figs. 7 and 15). Two mummies in their coffins stand before the chapel.

Fig. 20. Tomb of Raḥmose, No. 250. Ramesside. Dēr el-Medīnah. On the west wall. Publ. Bruyère, *Rapport* for 1926 (1927), Pl. vi.

No line of desert can be shown behind the tomb, since the drawing extends to the limit of the wall. Five mummies are set up in front. Except for the pyramid the building is of the same form as Fig. 1.

Fig. 21. Tomb of Amenemōnet, No. 277. Ramesside. Ḳurnet Mur'ai. See Porter-Moss, *op. cit.*, I, 163 (at 2 in plan).

The scene where the mummy, upheld by a man, is mourned and purified before the stela, is repeated on the stela itself; but the coffin is here supported by an Anubis-headed figure. On the other side of the chapel, beyond the hill-side in which the tomb is excavated, the mummy is carried down to its bier in the burial-chamber, where it is shown lying with its *ba* hovering over it. Farther along the wall Amenemōnet in his ordinary aspect worships Horus. The inscription, which ought to fill the horizontal lines on the stela, has been omitted. Another tomb of this type was represented in tomb No. 113 (Kynebu), now destroyed (see Wilkinson, *Manners and Customs* (1878), III, Pl. lxix). In tomb No. 30 a very similar edifice is preserved, but here the doorway is shown as an important feature with an arch above its cornice. See photo. in M. Baud, *Les dessins ébauchés de la nécropole thébaine*, p. 84.

Fig. 22. Tomb of Amenemḥab, No. 44. Ramesside. Shēkh 'Abd el-Ḳurnah. On south-east wall of first room.

The doorway leading to the inner chamber abuts upon the edge of the picture on the left, so that there is no room to show the desert. In front of the pictured tomb, on the right, a figure with Anubis-head supports a mummy before mourners. The columns on either side of the entrance are very roughly painted, but show traces of blue, yellow, and white. The door is yellow to represent wood.

Fig. 23. Tomb of Roy, No. 255. Ramesside. Dirā' Abū 'n-Naga. See Porter-Moss, *op. cit.*, I, 156, 161 (at 2 in plan). Publ. Baud and Drioton, *Le tombeau de Roj*, Fig. 8.

The stela shows on its upper part Osiris worshipped by Roy, while an inscription (not reproduced) fills the rest. Before it a figure with Anubis-head supports a mummy whose

feet are clasped by a mourning woman. The corner of the wall limits the picture on the right. The lower part of the scene is now destroyed.

Fig. 24. Tomb of Hūy, No. 14. Late Nineteenth Dynasty. Dirā' Abū 'n-Naga. On the south wall. Publ. M. Baud, *Les dessins ébauchés de la nécropole thébaine*, Pl. iii.

The subject appears to be the arrival of two funeral boats before a tomb or shrine where a mourning-woman and Isis meet them. It is included here on account of the pyramid on top of the building which is so characteristic of these representations, but the absence of the mummies and the presence of the boats make it probable that a shrine or temple and not a tomb is shown.¹ In tombs Nos. 147 and 249 also the boats are approaching a building which is clearly a shrine of Osiris (named as such), and not a tomb. That of tomb No. 147 has a garden in front. Traces of a garden can also be seen in Fig. 24, although the artist was not very clear as to what form the trees were to take. The whole drawing is a sketch in red paint. Some of the lines have been corrected by the draughtsman, and others, on the bottom left-hand corner, are now impossible to make out.

¹ In the duplicated representation of the tomb in No. 181 (Fig. 2), however, boats carrying funerary furniture are met by mourners before the building; see N. M. Davies, *The Tomb of two Sculptors at Thebes*, Pls. xix, xxi.

THE BREMNER-RHIND PAPYRUS—IV

BY R. O. FAULKNER

D. THE BOOK OF OVERTHROWING 'APEP (*concluded*)

THE present instalment, which concludes the translation of the Bremner-Rhind Papyrus, contains the remainder (Books 7–9, see *JEA* 23, 166), of the *Book of Overthrowing 'Apep* commencing with the variant version of the Creation-story. The book entitled *The Names of 'Apep* (Section E) follows after the Commentary on Section D.

Translation

THE BOOK OF KNOWING THE CREATIONS OF RĒꜥ AND OF FELLING 'APEP. RECITE:—Thus spake the Lord of All: When I came into being, 'Being' came into being. I came into being in the
 28 21 form of Khopri who came into being on the First Occasion; I came into being in the form ' of
 Khopri when I came into being, and that is how 'Being' came into being, because (?) I was
 more primaeval (?) than the primaeval ones whom I had made; I was the most primaeval (?)
 of the primaeval ones, and my name was more primaeval (?) than theirs (?), (for) I made
 22 primaeval time and the primaeval ones. I did all that I desired ' in this land, and I was all-
 pervading (?) in it. I knit mine hand, being alone, ere they had been born, ere I had spat out
 Shu or expectorated Tefēnet. I used (?) mine own mouth, and 'Magic' was my name. It was
 23 I who came into being ' in <my> form, having come into being in the form of Khopri. I came
 into being among (?) the primaeval ones, and there came into being a multitude of beings in
 the beginning, ere any being had come into being in this land; I alone achieved all that was
 24 made, ere there had come into being ' any other who could act with me in this place. I made
 the beings therein with this my soul; I created (some) of them in Nūn as an Inert One, when
 I could as yet find no place where I could stand. I considered (?) in mine heart, I surveyed '
 25 with my sight, and I alone achieved all that was made; I planned in mine heart, I created
 another being, and manifold were the forms of Khopri; their children came into being in the
 26 forms of their children (?). ' It was I who spat out Shu and expectorated Tefēnet. When I had
 come into being as sole god, there were three gods in addition to myself, and two gods came
 into being in this land; Shu and Tefēnet rejoiced in the Nūn, in which they were. It was mine
 27 Eye which brought ' them to me after a long age when they were far from me; I united my
 members, and they issued from me myself. After I had made excitation with my fist, my desire
 29 1 came into mine hand, and seed fell from my mouth; I spat out ' Shu and expectorated Tefēnet.
 When I had come into being as sole god, there were three gods in addition to myself, and two
 gods came into being in this land; Shu and Tefēnet rejoiced in the Nūn, in which they were.
 2 It was mine Eye which brought them to me after a long age ' when they were far from me;
 I united <my> members, and they issued from me myself. After I had made excitation with
 my fist, my desire came into mine hand and seed fell from my mouth; I spat out Shu and
 3 expectorated Tefēnet, and my father ' Nūn brought them up, mine Eye following after them
 since (? ?) the aeons . . . serpents, when I wept with tears over (?) [it ?]; mine [Eye ?] planned,
 4 and that is how men came into being. ' I replaced it with the Glorious One, and it was enraged
 with me when it returned, another having grown in its place, but its wrath died away (? ?)
 5 when I made replacement in it, and it was soothed (?). ' I promoted it in my face and it
 exercised governance over the entire land. Shu and Tefēnet begat Gēb and Nūt, <and Gēb
 and Nūt begat> Osiris, Horus Mekhantenirti, Seth, Isis and Nephthys, and they begat and

6 created many beings ¹ in this land, namely the forms of children and the forms of their children.

They made conjuration in my name that they might fell their foes; they created the magic
7 spells for felling 'APEP. He is ¹ imprisoned in the arms of Aker, he has neither arms nor legs,
and is confined (?) in one place, according as Rē^c obstructs him, for he has commanded that
8 he be felled on account of this his evil character. ¹ His face is cut away because of what he
has done, and he suffers for his evil character. Children fell him and sunder his soul from his
9 body and his shade, and the sages who are in the bark and the tears of mine Eye desire ¹ to
attack them. He shall be rendered impotent, and there shall be made no portion for him in
this land at <his ?> desire. He is despoiled (?) and his soul is despoiled (?); those who are in
10 the south fell him, those who are in the north fell him, those who are in the west fell him, ¹ and
those who are in the east fell him. O ye sages who are in this land, and ye Nine Gods who
came into being from my flesh, be ye vigilant in felling 'APEP! Exorcise him and destroy his
11 name; may your arms fell him, ¹ may ye not permit his name to be spread abroad; his children
shall not exist, his seat shall not exist, and he shall have neither soul nor body nor spirit, for
he belongs to the Eye of Rē^c, and it has power over him, it devours him. I am he who has
12 been sent to fell him, to destroy his name, ¹ and to chastise his name and his magic; I have
committed him to the flame, I have allotted him to the heat; I have given him to the Eye
of Rē^c, and the Glorious Eye has parched <him>, it has consumed his soul, his spirit, his body,
13 his shade ¹ and his magic, and he shall neither copulate nor become erect for ever and ever.

To BE RECITED OVER (an image of) 'APEP made of wax with his name written on it in
green ink; he shall also be made on a new sheet of papyrus, and the (images) of all the foes
14 of Pharaoh, ¹ dead or alive, shall also be made in wax, and their names written on them in
green ink, they being bound within a box (?); they shall be spat upon and trampled with thy
15 left foot, slaughtered with a knife, put on a fire ¹ of bryony and quenched with the urine of
a . . . woman. And the names of 'APEP and of all the foes of Pharaoh, dead or alive, are to be
written in pigment (?) on the ground, and trampled with thy left foot in the correct manner.
16 It is well for a man ¹ when he knows this matter of Rē^c and his creations; he will triumph over his
foes. It is a secret book of the House of Life (?), which none see; the secret book of felling 'APEP.

The stanza of conjuring their names. ¹ 'APEP is crushed, his confederacy is cut up, Rē^c
triumphs over his foes, the bark of Rē^c is enabled to sail in peace, 'APEP is made to retreat
18 BECAUSE OF fire, he is made to go to the execution-block of the god, <Ne>ḥaḥer is crushed ¹ in
very truth, and there are made to retire his soul, his body, his spirit, his shade, his children,
his heirs (?), his tribe, his family, his inheritance, his skin, his shape, his form, his tongue, his
19 egg, ¹ his name, his substance (?), his arms, his legs, his utterance, his magic, his spells, his
seat, his cavern, his tomb, his chamber (?). So is he to be felled and his (power of) movement
20 taken away, that he may not attack the Night-bark; ¹ the knife is given power over him daily
in the presence of Rē^c, who is made joyful when he has heard this book, and the bark of Rē^c
is enabled to sail in peace, 'APEP is crushed IN ALL HIS NAMES. Praise the god who created
21 his (own) strength, who binds ¹ the serpent and cuts up Neki the Ill-disposed One; may the
god be joyful at my words. Thus spake Isis unto Rē^c: Turn aside the rebel, that his eyes may
22 be blinded to the mysteries of heaven in very truth; chastise his soul even as his body, ¹ crush
his bones, may <he> be placed on the fire, may it be caused that he bite into his own flesh,
may he be given into the hand of the executioners of Rē^c, may he be caused to be turned away.

RECITE:—Get thee back, O 'APEP, thou bowel of Rē^c! GET THEE BACK, ¹ THOU INTESTINE
of the viscerae, thou fallen one, thou rebel, who hast neither arms nor legs, thou long-tailed
one who comest forth from thy cavern. O Bowel, retire before Rē^c, for I know the evil that
24 thou doest; thy head shall be cut off, ¹ thou shalt be cut to pieces, thy face shall not be lifted
up against the great god. Flame be in thy face, fire be in thy soul, the knife (?) of the great
execution-block be in thy flesh, mayest thou taste of the cutting of the great god, may Selket
25 conjure thee, may she turn thee aside. ¹ Depart (?), depart (?)! Fall, fall through this magic
in my mouth. <I> place thee on the fire, that it may destroy thee and that the Eye of

Horus may burn thee in thy brow. Fall on thy face! Thy soul is felled, for the Eye of Rē̄c
 26 has power over thee, and thou art fallen, ¹ fallen, and turned away, away, thou serpent who
 hast neither arms nor legs. Upon thy face! Thou shalt have no tomb, but thou shalt enter
 into the fiery furnace, for the great god who came into being of himself shall fell thee and
 27 those who are in ¹ his bark shall destroy thee in his bark by means of the spells of their utterance
 and by means of the magic which is in their bodies. <I> cast thee on thy back and thine
 30 ¹ intestines shall be cut out, for the executioners of Sakhmet slay thee, ¹ they fill their mouths
 with thy flesh, they squirt out (?) thy blood into the heat, thy head is broken with yonder
 knife, and the great god takes away thy (power of) movement. Retire, retire! Get thee back,
 2 get thee back! Be thou fallen and crushed! ¹ [Get thee back ?] in thy journeyings! The great
 god takes away thy legs, Rē̄c comes forth, Horus appears in glory, and mighty is their magic
 against thee; Rē̄c is triumphant over thee, O ḲAḲḲ.

Be thou spat upon, thou enemy; O rebel, Rē̄c cuts thee up. Be thou brought to naught,
 3 being utterly fallen. ¹ The fingers of Thoth are in thine eyes, his magic lays hold on thee, and
 thy form is annihilated, thy shape destroyed, thy body is annihilated, thy shade and thy magic
 4 crushed, for he takes away thy life, and thou shalt not snuff ¹ the breeze, the breeze. Fall!
 Be annihilated! Be thou disturbed, O thou who rebellest against the god; thou art allotted
 to the great cutting, thy [confederates ?] are smitten on their heads, thou hast no arms nor legs,
 5 and the spirit of thine heart is not in its place. ¹ Be thou cut up, cut up! Get thee back, get
 thee back! Creep away, for the spear of Horus goes forth against thee, the lance of Seth is
 thrust into thy brow, Rē̄c himself has destroyed thee. Thy voice is done away, and thou hast
 6 no cry of joy, for thou art utterly crushed. ¹ Thy form is not, for thou belongest to the Eye
 of Horus, and it has power over thee daily.

O ḲAḲḲ THOU FOE OF Rē̄c, may Rē̄c crush thee, may Atūm turn thee back with the spells
 7 of their (*sic*) utterance. Mayest thou hear my magic utterances, ¹ mayest thou die because of
 them, even as Rē̄c commanded should be done to thee. O ḲAḲḲ THOU FOE OF Rē̄c, I know what
 thou hast done; come, turn thee back because of thine evil deeds; thou art fallen in thine evil
 8 moment. Arise! Rē̄c exorcises thee, the Great Ennead testifies against ¹ ḲAḲḲ THE FOE OF Rē̄c.
 Thou art fallen and felled; fall thou in this their moment, for I have given thee over to the
 knife, and it has power over thee <through ?> these knife-bearers who are in his bark. Thou
 9 art (condemned) to the fire, and it has power over thee ¹ daily; thou art (condemned) to the
 execution-block, thy face is toward it. Isis fells thee with her magic. Thou art (committed)
 to the Eye of Horus, and Wosret the burning one, she burns up thy soul. Thou belongest to
 10 Horus, the heir of the great god, and his spear which is in his hand ¹ goes forth against thee.
 Thou belongest to Seth the son of Nūt, and he breaks thy vertebrae, he severs thy neck, and
 stabs thee with this his strong lance which is in his hands. Thou belongest to the Eye of Rē̄c,
 11 the fiery glance of Horus, and it consumes ¹ thy body. Thou belongest to the crew of Rē̄c who
 row Rē̄c, and they drop thine head on the ground. Thou belongest to Horus Mekhantenirti,
 who kills thee with this his knife which is in Letopolis. Thou belongest to the wardens of
 12 the ¹ mysterious portals, and their fiery blast and their flame go forth against thee, the great
 and terrible one devours thee and she is satisfied with thy body, O ḲAḲḲ THOU FOE OF Rē̄c.
 13 Mayest thou not travel by water or land, ¹ mayest thou not exist, mayest thou not rise up (?).
 A soul goes forth against thee in the west, and thou art (condemned) to the flame which is
 on its mouth; the iron of Horus goes forth against thee in the east, and thou art (condemned)
 14 to the magic which is in his body. Those who are in their shrines cut thee up, ¹ they stick (?)
 their arrows in thee, they cut thee to pieces again and again, thou being cast into the furnace
 of the god at the hall of sacrifice of the Flesh-Eater, at the hell of the crew of Rē̄c, at the
 15 execution-block of Thoth. All the gods take ¹ their meat-portions (?) out of thee, their hearts
 are satisfied at cutting thee to pieces.

O ḲAḲḲ, THOU FOE OF Rē̄c, get thee back! Thy head is turned back to the ground, thy
 (power of) movement is destroyed, and thou art totally blinded. Thou shalt not be, thy like-
 16 ness shall not be, ¹ thy shape shall not be, thou shalt not come against Rē̄c in his two heavens

when Rē^c is in his heavens; he shall triumph over thee, thy tail shall be placed in thy mouth,
 17 and thou shalt chew thine own skin, it being cut into upon the altar of the gods, of ¹ the Great
 Ennead which is in Heliopolis. Thou art fallen and felled, for they fell thee. The evils go
 forth, their fiery blast goes forth against thee in fire, they cry out against thee with fire, their
 18 faces are against thee with their flame, ¹ . . . with knives of flint, they burn thee in thine
 intestines, they crush thee with their knife(s) which are in their hands, the Children of Horus
 19 crush thee, their magic enters into thee, ¹ their spells come into being against thee, thou being
 conjured on water and on land, and thou being conjured in every form which thou hast assumed
 20 in this thine evil hour; mayest thou not attack the Night-bark or the gods in ¹ it; get thee
 back, thou rebel. May thy soul be destroyed, for thou art cut up, thou art driven off from
 the sacred bark, thou art exorcised, thou art felled, and the Eye of Rē^c devours thee.

21 Get thee back, thou rebel, be thou annihilated, for the arrows ¹ of Horus are shot into thy
 nose. Oho! 'APEP is crushed, Rē^c has power over his foes, this Glorious Eye devours thee in
 this its name of 'Devouring Flame', it consumes thee, it gulps thee down by means of the
 22 magic ¹ of their (*sic*) utterance, and it has overcome thee. Thou diest for them (*sic*), they fell
 thee, they repel thee, they have power over thee, and thou art brought to naught, being
 annihilated and turned back. The Great Ennead which is in Heliopolis cuts thee up, the Great
 23 One chastises [thee]. ¹ Great is the fire and sore the heat, and thou art (condemned) to the
 fiery blast which is in her mouth. She has annihilated <thee>, O 'APEP, she has repelled thee
 in thine evil coming forth; fire is on thee, it consumes thy flesh and makes thee into ashes, it
 24 burns up ¹ thy soul and broils thy bones and thy members; the fiery glance of Horus, the Eye
 of Rē^c, it acts against thee, and Seth thrusts his spear into thine head. Thou art (committed)
 25 to the fierce lion, the son of Bastet, lady of terror, and he is satisfied with thy blood. ¹ Fire is
 on thee in all thy ways, Pakht has condemned thee, her flame is the great flame, lady of terror,
 mistress of fire, and she takes away thy flesh, she condemns thy soul, <her> flame has burnt
 26 thee up. ¹ O 'APEP THOU FOE OF Rē^c, those who are in the shrine devour thee, even the Great
 Ennead which is in the bark, so that thou mayest not exist. Thou shalt not exist, thou shalt
 suffer; when thou sleepest thou shalt not awake, for Rē^c has felled thee for ever. Thou shalt not
 31 1 endure in ¹ the sky, thou shalt not be on earth, for thou art destroyed by this great knife, being
 cut to pieces again and again. Fall thou to the knife of the god, for the trap is on thine head,
 2 the spear in thy back and the barb of Rē^c ¹ firm-fixed in thy brow, thou being fallen in thine
 evil moment, and burnt up in this moment of Horus. The god goes forth against the rebel to
 3 fell 'APEP, and THY FACE IS TOWARD THIS EXECUTION-BLOCK OF Yat-Pega, ¹ thou being destroyed
 in it for ever and ever. Thou shalt not become erect, thou shalt not copulate, thy young shall
 not come into being, thine egg shall not grow, but the gods who came forth from the Eye of Horus
 4 shall cut thee up, thou being sought out and fallen. ¹ Rē^c-Ḥarakhti fells thee, the spear in his hand
 goes forth against thee, his arrow strikes into thee, AND THOU ART BECOME NON-EXISTENT.

BE THOU ANNIHILATED, O 'APEP THOU FOE OF Rē^c—FOUR TIMES. THOU SHALT NOT EXIST
 AND THY SOUL SHALL NOT EXIST; THOU SHALT NOT EXIST AND THY BODY SHALL NOT EXIST; ¹
 5 THOU SHALT NOT EXIST AND THY CHILDREN SHALL NOT EXIST; THOU SHALT NOT EXIST AND
 THINE ARMS SHALL NOT EXIST; <THOU SHALT NOT EXIST> AND THY FLESH SHALL NOT EXIST;
 THOU SHALT NOT EXIST AND THY BONES SHALL NOT EXIST; THOU SHALT NOT EXIST AND THY
 6 MAGIC SHALL NOT EXIST; THOU SHALT NOT EXIST AND THY MOUTH SHALL NOT EXIST; ¹ THOU
 SHALT NOT EXIST AND THY FORM SHALL NOT EXIST; THOU SHALT NOT EXIST AND THY SHAPE SHALL
 NOT EXIST; THOU SHALT NOT EXIST AND THY BEING SHALL NOT EXIST; <THOU> SHALT NOT EXIST
 AND THY SKIN SHALL NOT EXIST; THOU SHALT NOT EXIST AND THY HOUSEHOLD SHALL NOT
 7 EXIST; THOU SHALT NOT EXIST ¹ AND THY SEED¹ SHALL NOT EXIST; <THOU> SHALT NOT EXIST
 AND THY SUBSTANCE (?) SHALL NOT EXIST; THOU SHALT NOT EXIST AND THY SEAT SHALL NOT
 EXIST; THOU SHALT NOT EXIST AND THY GRAVE SHALL NOT EXIST; THOU SHALT NOT EXIST AND
 THY CAVERN SHALL NOT EXIST; THOU SHALT NOT EXIST AND THY TOMB SHALL NOT EXIST; <THOU>
 8 SHALT NOT EXIST ¹ AND THY ROADS SHALL NOT EXIST; THOU SHALT NOT EXIST AND THY DEEDS

¹ Or 'poison'.

SHALL NOT EXIST; THOU SHALT NOT EXIST AND THINE UTTERANCE SHALL NOT EXIST; THOU SHALT NOT EXIST AND THINE ENTERING SHALL NOT EXIST; THOU SHALT NOT EXIST AND THY GOING
 9 SHALL NOT EXIST; THOU SHALT NOT EXIST¹ AND THY TREADING SHALL NOT EXIST; THOU SHALT NOT EXIST AND THY SAILING SHALL NOT EXIST; THOU SHALT NOT EXIST AND THY SITTING SHALL NOT EXIST; THOU SHALT NOT EXIST AND THY GROWING SHALL NOT EXIST; THOU SHALT NOT EXIST AND THY BODY¹ SHALL NOT EXIST; THOU SHALT NOT EXIST AND NO PLACE WHERE
 10 THOU ART SHALL EXIST;¹ O 'APEP THOU FOE OF RĒĀ, THOU SHALT DIE, DIE! MAYEST THOU PERISH, MAY THY NAME PERISH, THY TEETH BE SOFT, THY POISON SPILT; MAYEST THOU BE BLIND
 11 AND UNABLE TO SEE. FALL UPON THY FACE; BE FELLED, ¹ FELLED! Be crushed, crushed! Be annihilated, annihilated! Be slain, slain! Be cut to pieces, to pieces! Be cut up, cut up! Be severed, severed! Be slaughtered, slaughtered! Thy head shall be cut off with this knife
 12 in the presence of RĒĀ every day, for he allots thee to Aker, and he crushes thy bones. ¹ Retire, for RĒĀ-Harakhti has felled thee, thou art given over to the god who averts ill through his words. The barb of Horus is thrust into thy brow, thine head is severed from thy neck, thy
 13 soul is fallen, thy shade is not, thou art destroyed at the execution-block; ¹ thy head is cut off, and thou art cast on thy back.

Get thee back, thou rebel, thou foe of RĒĀ! Thou art cut up in thine evil coming forth, the uraeus of Horus consumes thee, it devours thee in order to satisfy its heart, its fiery blast is
 14 on thee, ¹ its flame is on thee. Retire, turn back, O 'APEP, in this thine evil hour; the Nine Gods lift up their faces against thee, they spit their flames into thine eye. Fire is on thee, and
 15 sore is the flame; it has power over thee, ¹ it has heated thee, it has burnt thee, and thou art (condemned) to the fiery blast which is in its mouth. Be thou cut up! Thy vision is averted by RĒĀ, Horus in his bark blinds thee, he has power over thee; Wosret (?), she cuts thee up.
 16 The knife is on thee, ¹ its destruction is for thy members, and thou shalt not come against the bark of the great god. RĒĀ himself turns thee back, and thou art (bound) for the execution-block, thy face is toward it. The Ennead which is in his shrine fells thee, they fell thee, and
 17 thine ears are stopped up and deaf. ¹ Isis fells thee with her magic, she closes thy mouth, she takes away thy (power of) movement, and she will not give RĒĀ over unto thee for ever and
 18 ever; this his spear is turned back in thy flesh. Be silent! ¹ Fall! Thou shalt die, and not live, for Isis and Nephthys fell thee; together they avert thy rage. Retire, turn thee back!—and *vice versa*. Be thou blind, be annihilated!—and *vice versa*. Thy soul is destroyed, and
 19 thou shalt not live ¹ for ever and ever. Thy moment is averted, thy strength taken away, and flame is on thy body, fire is on thee, <it> chastises thy body, it burns up thy bones. The
 20 flame is gone forth that it may burn up thy soul and consume ¹ thy body, Wepes the great chastises thee, her flame is on thy flesh, and thou art turned again to thine execution-block which RĒĀ made (?). Thoṯ cuts thee to pieces with his magic and thou canst not come against
 21 the bark ¹ of RĒĀ; RĒĀ himself turns thee back, for he knows all that thou hast done evilly.

Fire is in thee in the south, and it has power over thee; it is Sothis and Anūkis who have commanded what is done against thee. Fire is in thee in the north, and it has power over
 22 thee; it is Wadjet, ¹ Lady of Pe and Dep, who has commanded what is done against thee. Fire is on thee in the west, and <it has power over thee>; it is Ḥa, Lord of the West, who has commanded what is done against thee. Fire is in thee in the east, and it has power over thee;
 23 it is Sopd, Lord of the East, who has commanded what is done against thee. ¹ Thou shalt not be in any place of thine where thou art, for indeed it has power over thee, and thou art (condemned) to this fire of the Eye of RĒĀ; it sends forth (?) its fiery blast against thee in this its
 24 name of Wadjet; it consumes thee in this its name ¹ of 'Devouring Flame'; it has power over thee in this its name of Sakhmet; it is fiery against thee in this its name of 'Glorious Serpent'. Thou shalt die in the flame of fire; thou shalt be blind and the Eye of Horus shall have power
 25 over thee; ¹ it shall take away thine arms, it shall remove thy legs, and thou shalt be rendered impotent. It is RĒĀ who brings about evil in thee, it is Horus who cuts thee to pieces, thou
 26 being bound, fettered and fallen. Thy soul is sundered from thy shade, ¹ thy head is bound—

¹ Repeated from above, 31, 4-5.

sentences is a verb which, judging from the context, must be related to the auxiliary verb *prw* 'to have done in the past' (Gardiner, *op. cit.*, § 484), and it has been tentatively rendered as 'to be primaeval'. Roeder's translation of *pr* as 'to exist' is difficult to justify, and Budge's 'I rose up' is even wider of the mark. $\downarrow e$ here and below after *rn-i* is clearly for the preposition *r*, which probably has comparative force. In *pr-n-i m prwtjw* the preposition perhaps carries a nuance of the superlative, cf. Gardiner, *op. cit.*, § 97, third example. $\downarrow e$ should doubtless be emended into *pr-n rn-i r-sn*; $\downarrow e$ clearly stands for *ir-n-i*, with mis-writing of \downarrow for $\downarrow e$, while *prwt* immediately following must be the word for 'primaeval time'.

28, 22. *Wsh-n-i im-f*, lit. 'I was wide in it' (*scil.* this land) perhaps means that the influence of the Creator pervaded the land through and through; Roeder's rendering 'und war in ihm weit(-hin herrschend?)' embodies much the same idea.—*ts-n-i drt-i w-kwi* 'I knit my hand, being alone' alludes to the mode of creation employed by the solitary sun-god, compare *Pyr.*, § 1248 and above 26, 24.—In *nn ms-sn* (older *n msyt-sn*) the suffix must refer to the 'primaeval ones' mentioned above.—*In-n-i r-i ds-i*, lit. 'I brought mine own mouth'; the translation of the verb as 'used' is unavoidable as the text stands. Roeder's translation 'Ich brachte (sie aus) meinem Munde herbei' assumes the omission of *sn m* after *in-n-i*, but the parallel $\downarrow e$ \rightarrow $\downarrow e$ \rightarrow $\downarrow e$ \rightarrow $\downarrow e$ \rightarrow $\downarrow e$ 'I spat with mine own mouth' 27, 1 speaks against his emendation, for it suggests that $\downarrow e$ here is to be regarded as an approximate equivalent of *hr m*.

28, 24. *ts-n-i im m Nwn m nn* 'I created some in Nūn as an Inert One'; with this compare *ts-n-i im-sn m Nwn m nww* 26, 22-3, with the n. thereon. Here *nn* 'inert one' appears to refer to the Creator, whereas in 26, 23 the plural strokes suggest that there the term is applied to the newly created beings.

28, 24-5. For *sh-n-i m ib-i*, *snt-n-i m hr-i* see n. on 26, 23.



28, 25. For *ir-n-i iry(t) nbt* 'I achieved all that was made', 26, 23 has *ir-n-i irw nbt* 'I made every shape'.—*Kms-n-i ky hprw*, $\downarrow e$ *hprw nw Hpri*, *hpr-in msw-sn m hprw nw msw-sn* 'I created another form, and manifold were the forms of Khopri; their children came into being in the forms of their children' shows signs of textual corruption, especially as regards the last sentence, which is well-nigh unintelligible; the version of 26, 24 is perhaps nearer the archetype. $\downarrow e$ \rightarrow $\downarrow e$ \rightarrow $\downarrow e$ is probably to be regarded as the *sdm-in-f* form, which occurs above in *ms-in* 27, 4-5.

28, 26. *Hpr-n-i m ntr w* 'when I had come into being as sole god'; the translation as a temporal clause is indicated by the variant *m-ht hpr-i m ntr w* of 27, 1-2.—*Hpr ntrwy m ts pn* 'two gods came into being in this land'; the parallel of 27, 2 has *hpr-n-i m ts pn*. The 'two gods' of the present passage are clearly Shu and Tefēnet, the third of the three mentioned above being presumably Nūn, who as the embodiment of the primaeval watery abyss could hardly be in 'this land'.

28, 26-7. *In irt-i in n-i sn m-ht hnty* 'it was mine Eye which brought them to me after a long age'; this sentence is just the reverse of 27, 2, where it is Shu and Tefēnet who bring back the far-wandering Eye, and it is clear that the author of the present version has not understood the allusion to this legend and that he has accordingly emended his text to refer to the bringing of these two deities from out of the primaeval waters. For *m-ht hnty* 'after a long age', see *Wb.*, III, 106, 14.

29, 1-2. The scribe has erroneously repeated 28, 26-7 'When I had come into being as sole god . . . I expectorated Tefēnet'.

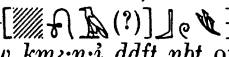
29, 3. *Irt-i m-sr-sn wbw sp 2 hnty*; this sentence is quite unintelligible as it stands, and should probably be emended to agree with the parallel in 27, 1, which has *irt-i m-sr-sn dr*

hnty wꜣsn rꜣi 'mine Eye following after them since the aeons when they were far from me', see the n. thereon. The word *wꜣbw* here and in the next sentence is utterly obscure; it occurs twice in 27, 4, see the n. thereon, as well as below in 29, 4. From here on to 29, 6 the text is most confused, the component sentences occurring out of all order and words being omitted. In the translation the existing arrangement of the text has been retained, but for an intelligible sense it is necessary to refer to the previous version.—[ (?)]  is unintelligible. It apparently corresponds to *pr-nꜣi m wꜣbw kmꜣ-nꜣi dꜣdft nbt* of 27, 4, and if so is misplaced here; it should possibly precede *ms Šw Tfnt* in 29, 5.—*Hpr pw rmt* should presumably follow directly after *rmꜣi m rmw r . . .*, while the intervening *kꜣn [irt?]ꜣi*, which has no parallel in the other version, should perhaps be inserted before *m rmꜣi*.



29, 3-4. According to 27, 3, *dbꜣ-nꜣi sw m šht* should follow *kt rd-tw m stꜣs*; the latter sentence has no introductory *gmꜣs*.

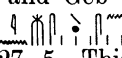

29, 4. *Hr-tw dndnꜣs iw wꜣbwꜣs hr wꜣbw* and *dbꜣ-nꜣi imꜣs* correspond to *hr n stꜣsn iw wꜣbwꜣsn* and *dbꜣ-nꜣi itꜣiꜣs imꜣs* in 27, 4; the first sentence should perhaps read *hr-n dndnꜣs r wꜣbwꜣs*, see n. on 27, 4, and both should doubtless follow *hkꜣ-nꜣs tꜣ drꜣf* (29, 5) as in 27, 4.

29, 4-5. *Nꜣ imꜣs* does not occur in the parallel text. Literally perhaps 'smoothness was in it', the meaning of the expression is by no means clear, but it may perhaps refer to the soothing of the enraged Eye. On the sense of *nꜣ* as 'smooth' (not 'many-coloured' as *Wb.*, II, 208) see Gardiner, *Hierat. Pap. BM*, III, p. 41, n. 5; 49, n. 1.

29, 5. For *hnty irꜣf* read *shnty-nꜣi irꜣf* or perhaps *irꜣ-nꜣi shnty irꜣf* as 27, 3.—*Ms Gb Nut* 'and Gēb and Nūt begat' has been omitted before *Wsir* 'Osiris', compare 27, 5.—For  read perhaps *msꜣ-inꜣsn*; for the use of the *sdmꜣ-inꜣf* form in this context compare 27, 5. This sentence is a combination of 'there came into being a multitude of forms of living creatures, namely the forms of children and the forms of their children' 26, 24 and 'they begat their multitudes in this land' 27, 5; *kmꜣ* is perhaps inserted under the influence of *kmꜣ-nꜣi dꜣdft nbt* in 27, 4.

29, 6-7. *Iwꜣf hr sꜣw hr ꜣwy n škr* 'he is imprisoned in the arms of Aker' is lit. 'he is guarded upon the arms of Aker'; for *sꜣw* with a nuance of captivity compare the expression *rmt sꜣw* 'prisoner' (lit. 'guarded man') *Horus and Seth* 15, 12. The preposition in *iwꜣf hr sꜣw* should be omitted, as the construction intended is with the old perfective.

29, 7.  is unknown to the *Wb.*, and the translation 'confined' is a guess based solely on the context; Budge renders it as 'fettered'. For the following  read .—For *hw sꜣdb* 'to implant an obstacle against', 'obstruct' see 27, 7 and the n. thereon.—*Wꜣ-nꜣf iw(=r) šhrtꜣf*, lit. 'he has made command to fell him'; the first suffix refers to Rēꜣ.

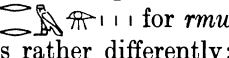
29, 8. For  read doubtless ; the construction is that of Gard., *Eg. Gr.*, § 374.— is apparently a writing of *msw* 'children', but who these children are remains obscure. Budge suggests that they are those of Shu and Tefēnet, presumably Gēb and Nūt, though the grounds for this supposition are not clear; they might equally well be those mentioned above in 29, 6.—*Rhyw-ht imꜣyw wꜣs* 'the sages who are in the bark' are doubtless identical with 'the gods in the bark (of Rēꜣ)', compare 27, 25, while *rmw n irtꜣi* 'tears of mine Eye' must mean 'human beings', see above 27, 2-3; 29, 3; the whole expression is clearly an elaborate periphrasis for 'gods and men'. On the writing  for *rmw* see Gardiner, *Late-Eg. Stories*, 100a. The parallel text in 27, 5 reads rather differently: 'the gods who are in his bark desire to attack him, and the tears which issued from mine Eye are against you'.

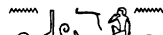

29, 9. On *wꜣ sꜣdbꜣf* see the n. on 23, 20.—*Nn irꜣ nꜣf hrtꜣf m tꜣ pn n mrwt* 'there shall be made no portion for him in this land at (his?) desire'; possibly the suffix *f* should be supplied

after *mrwt*.—On *wšr* ‘to be despoiled (?)’ see the n. on 27, 18.—*Šhr s(w) imyw rsy* ‘those who are in the south fell him’, &c.; compare 27, 21.

29, 12. For  read *ntb·n·s sw*; the two successive *s* have coalesced.

29, 13–14. *Hnš irw rn n hftyw nb n Pr-ꜥ . . . m mnḥ*; here *rn n* ‘the names of’ is clearly an error, since the reference is obviously to waxen images; the next sentence orders the names to be written on the images.

29, 15. The word  is of uncertain reading and meaning; Budge’s translation ‘tile (?)’ suits the determinative, but Roeder’s ‘Kreide (?)’ perhaps yields a better sense. Since, however, chalk is not a characteristically Egyptian product, I have adopted the non-committal rendering ‘pigment’.

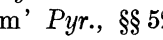
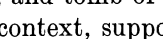

29, 16. *Hwt hkš rn·sn* ‘the stanza of conjuring their names’; for *hkš* as a verb see *Wb.*, III, 177, 7. The suffix in *rn·sn* presumably refers to ‘Apep and his myrmidons. For the queried reading  of my transcription, Posener, in a letter to Gardiner, convincingly suggests , pointing out that the ‘House of Life’ is a more likely source for a magical book than the treasury.

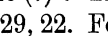
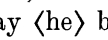
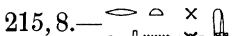
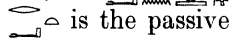
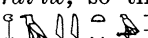
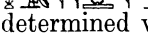
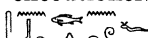
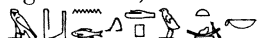
29, 19. *Pꜣctyw* ‘substance’ (so Budge and Roeder) is perhaps the same word as  ‘primaeval form’ *Pyr.*, §§ 521*d*; 522*d*.—, mentioned in conjunction with the throne, cavern, and tomb of ‘Apep, is quite obscure; the rendering ‘his chamber (?)’, suggested by the context, supposes a possible corruption of . Roeder has ‘seine Pyramide (?)’. The whole long sentence has an approximate parallel in 28, 7 ff.

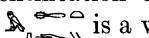
29, 22. For  ‘to turn back’ read  ‘to crush’, cf. *Wb.*, IV, 215, 8.— ‘may (he) be placed on the fire’; the following sentences show that  is the passive *rđi·tw*, so that the subject of the verb, presumably the suffix *f*, has been omitted.— is doubtless identical with  *P. Ed. Smith*, 18, 6; *Eg. Rel.* 2, 133; determined with a monkey brandishing knives *Cenotaph of Seti I*, Pl. 88, 2, 4.¹ The det. in the last-quoted instance, taken in conjunction with the Bremner-Rhind context, suggests that the word is more likely to be related to *hꜣyt* ‘massacre’ than to *hꜣyt* ‘disease’ as suggested by Breasted, *Edwin Smith Surgical Papyrus*, I, 475, so that Budge’s rendering ‘executioners’ is probably not far from the mark. This word occurs again in 29, 27.—For  read *šn·tw·f*. This verb occurs transitively also in  ‘steer not thy boat awry’, *Peas.*, B 1, 221.

29, 22–3. The contemptuous identification of ‘Apep with the viscera of Rēꜥ is due to the serpentine form of the demon.  is a writing of *imy·ht* ‘viscera’; for the expression *k(ꜣ)b n imy·ht* in this context see *Wb.*, V, 9, 19.

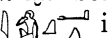
29, 24.  is probably a corruption of *sft* ‘knife’.—*Hnm·k m šꜥd n ntr ꜥ* ‘mayest thou taste of (lit. “be presented with”) the cutting of the great god’; with this use of *hnm* compare *hnm m šht* ‘belaboured with blows’, *Adm.*, 5, 12.

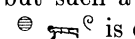
29, 24–5.  is apparently the imperative with prothetic *i* of a verb *kꜥ* which seems to be otherwise unknown. One is tempted to connect it with the Late-Eg.  ‘to wander’ *Horus and Seth*, 7, 5, in view of Sethe, *Verbum*, I, § 148; in any case the meaning here must be something like ‘depart!’ Budge renders ‘enter’, apparently supposing *kꜥ* to be a mis-writing of *ꜥk*, but such a translation is clearly the exact opposite of the sense required. The following  is old perfective with exclamatory force.

29, 25. For *šhtm·n·s* read *šhtm·s*.

29, 27. On *hꜣyt* ‘executioners’ see the n. on 29, 22.

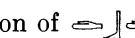
30, 1. The translation of  as ‘squirt out’ (Budge has ‘spill’) is doubtful, but the rendering of *Wb.*, V, 442, 16 as ‘schlürfen’ is difficult to reconcile with the following

¹ I am indebted to Professor Gunn for these references.

hr tw. There are two other verbs *dbdb* found in this papyrus, namely, 'to cut through' the skin of 'Apep, 27, 8; 28, 6; 30, 16; and 'to attack' the Night-bark, 29, 19, var. 23, 13; 30, 19.

30, 3. in *nn wn dp-k tw* is not the verb 'to spit' but is clearly intended for 'to breathe'.

30, 4. is a writing of , see *Wb.*, III, 295, 383.

30, 8. For read $\langle m \rangle$ *mdsy* rather than *m-c dsy* 'through the knives', since the wielders of the knives are clearly meant.

30, 9. 'thy face is toward it' means 'thou art bound in that direction'. The same expression is found in 'although I had found a ship which was bound for Egypt' *Wenamun*, 1, 40-1.

30, 11. is to be read *bhnu*, for the first sign is *bh*, not *mt*. The word may be identical with 'knife' *Wb.*, I, 468, 19.

30, 12. For read *wnm twk*; this Late-Eg. pronoun occurs also above, 26, 17, end, and below, 30, 13.— is probably a writing of *Nrwtt*, the vulture goddess who personifies terror; the suffix in the following *htp-s* shows that the word is feminine.— 'mayest thou not travel by water or land' is lit. 'mayest thou not sail, mayest thou not journey'; for read while is an obvious corruption of which is also found above in 26, 15.

30, 13. is difficult, since none of the recorded meanings of this verb fit the context. In rendering 'rise up (?)' a confusion with is assumed; for another instance of this confusion see *Wb.*, v, 399, 2.

30, 14. *Dbr-sn ssr r* 'to stick (?) arrows in (some one)' is an idiom apparently unknown elsewhere, but it is probably a development of *db* in its sense of 'to put on' clothes *Wb.*, v, 556, so that the literal meaning would be 'they put their arrows on thee'.—For read cf. 28, 13; in 27, 19 the same word is written .

30, 15. is perhaps to be identified with 'portion of meat' or with the almost synonymous ; according to *Wb.*, iv, 437, 4 is also used of the dismembered limbs of the Sethian hippopotamus. The sense here is apparently that the gods devour as food the portions into which 'Apep has been cut.



30, 17. *Sbh-sn r-k m sdt* 'they cry out against thee with fire'; the meaning is that when the gods cry out against 'Apep, fire leaps from their mouths.



30, 17-18. The reading at the division of the lines is very doubtful, and the absence of any suffix after adds to the difficulty; the preposition in and the following further speak against the reading , but it is difficult to see how else to interpret the traces. 'knives' appears to be otherwise unknown.

30, 22. For the transitive use of *sh* see *Wb.*, iv, 248, 19. The use of the dependent pronoun shows that here at any rate there is no omission of the preposition *m*, but that the verb is indeed used transitively.

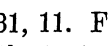
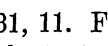

30, 26. *Nkm* originally meant 'to be bald' or the like, see *Pyr.*, §§ 521*b* (no det.); 2055*b*, 2056*b* (det.) but later it comes to mean 'to suffer', see *JEA* 16, 21. To our ideas such a remark as 'thou shalt suffer' is superfluous, if not contradictory, after such an all-inclusive threat as 'thou shalt not exist', but such discrepancies are common form in these texts.—For *sdr-n-k* read doubtless *sdr-k*.

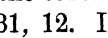
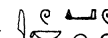
31, 3. is the plural of *tr* 'young' of birds, 'fledgling', used to refer to the young of serpents; the derivation is shown clearly by the determinative . For other instances of the widened area of meaning of this word see *Wb.*, v, 340, 4 ff.

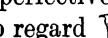
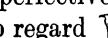
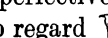
31, 11. For  read  , see the n. on 29, 22, and for  read  , see the textual n.

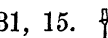
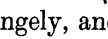
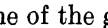
31, 12. In    the words *sb* *sk·tw* are difficult, since *sb* is apparently a participle referring to *ntr*, while *sk·tw* has the appearance of the old perfective 2nd sing., which is an impossible combination. The simplest solution perhaps is to regard  as a writing of the noun  or possibly  (*Wb.*, I, 21) and to translate 'who averts ill' as an epithet of *ntr*; for this sense of *sb* see *Wb.*, III, 431, 11.

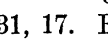
31, 15.  'he has power over thee and over thy neck' reads strangely, and the feminine suffix in *ir·s šd·k* suggests that  is a corruption of the name of the goddess  in anticipatory emphasis, cf. 27, 16; 30, 9.

31, 17. For  of the autographed text read  , see my note *JEA* 21, 51.

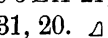
31, 20.  is apparently a relative form referring to *nmt* 'execution-block', though *irt·n* is what one would expect in such a case. It can hardly be an independent sentence 'Rēc has created' unless a word or words representing the object of the verb have been omitted after it.

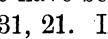
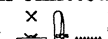
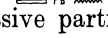
31, 21. In  , *n* corresponds to original *m*.—In  the first word is probably the passive participle, corresponding to Middle-Egyptian  ; the ending can hardly be the plural suffix *w*, as there is no plural noun to which it could refer.

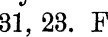
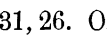
31, 23. For  read probably  *hh·s*.

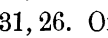
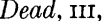
31, 26. On the expression  cf. Gardiner, *Hierat. Pap. BM*, III, pp. 59, n. 2; 85, n. 4.—*Sdr mr* 'lie down in pain'; for the adverbial use of *mr* see Gardiner and Sethe, *Letters to the Dead*, III, 3 (n.).—On  in the sense of 'turn away' some one cf. the n. on 29, 22.

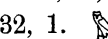
32, 1.  is difficult and probably in part corrupt; possibly one should emend into *hr nn iryt m wy·k*.

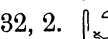
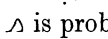
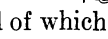
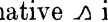
32, 2.  is probably identical with  *Wb.*, IV, 342, 6, used of the flowing Nile, and of which  'to froth up (?)' of beer, *Two Brothers*, 8, 6; 12, 9 is clearly a derivative; the sense here seems to be that the waters shall rise up in storm against 'Apep. The determinative Δ is taken over from  'to remove by force', *Wb.*, V, 297, 11.

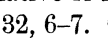
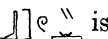
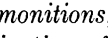
32, 6-7. On  see the n. on 28, 15. In the following sentence the restoration [] ϵ is very doubtful; what is needed is a verb expressing enmity to Pharaoh, compare the next sentence and 28, 15. For *nh* 'danger (?)' cf. Gardiner's note on *snh* in his *Admonitions*, p. 48.— is not found in the *Wb.*, but the determinative gives a clear indication of the general sense.

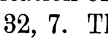
32, 7. The change to the 2nd person in  is disconcerting, as apparently it has no antecedent; the context suggests, however, that it must refer to Pharaoh (see the next n.), in which case we should emend the suffix to ω .

32, 8. The suffix in *iw·f m wptwy* appears to refer back to 'Pharaoh' in 32, 7. The whole passage down to 32, 9 seems to be a glorification of the king.—On the superfluous $\frac{1}{2}$ in *dšdšt* see Gardiner's note in *Hierat. Pap. BM*, III, p. 17, n. 13; cf. also *ZĀS* 73, 74, where he shows that it is a corruption of $\frac{1}{2}$.

32, 10-11. In *iw Rē m mkt·f, mkt Gb Pr·c; <m> mkt Rē, ntf mkt·f sw* we have a play on *mkt* 'place' and *mk* 'protect', the latter being written with the same determinatives as the former. After *Pr·c* we should probably read *<m> mkt*.

32, 11. With *in Rē htm n·f r nb* 'It is Rēc who shuts for him every mouth' compare the spell published in *ZĀS* 65, 35, and also see above, 27, 10-11; *dš(r)* at the end of the sentence has been given a deletion-mark by the scribe and is not to be translated. The

latter part of this passage recalls *Pyr.*, § 16a.—On a possible emendation of the corrupt  see the textual note.

E. THE NAMES OF 'APEP

This text, which occupies the lower half of col. 32 with a double column of text and concludes with 18 short lines in col. 33, consists of a series of epithets of 'Apep, which are often unintelligible, followed by instructions for making magical figures of 'Apep and other evil beings (32, 13–54), these instructions in their turn being succeeded by a short hymn to Rēc (col. 33). It is really little more than a magnified rubric added as an appendix to the long text of the 'Book of Overthrowing 'Apep' which precedes it.

Translation

- 32 13 THE NAMES OF 'APEP, WHICH SHALL NOT BE.
 'APEP, THE FALLEN, THE MANGLED (?).
 15 'APEP, THE FALLEN, THE MOST EVIL (?).
 'APEP, THE FALLEN, THE FIERCE-FACED.
 'APEP, THE FALLEN, THE ROARER.
 'APEP, THE FALLEN, THE ILL-DISPOSED.
 'APEP, THE FALLEN, THE *KRN*.
 20 'APEP, THE FALLEN, THE *YBNY*.
 'APEP, THE FALLEN, THE DEVOURER (?).
 'APEP, THE FALLEN, THE BREAKER OPEN OF LANDS.
 'APEP, THE FALLEN, THE DESPOILER OF THE LAND.
 'APEP, THE FALLEN, THE ENEMY (?).
 25 'APEP, THE FALLEN, THE DARK ONE (?).
 'APEP, THE FALLEN, THE TORTOISE.
 'APEP, THE FALLEN, THE *SRM*.
 'APEP, THE FALLEN, THE POTENT OF GLANCE.
 'APEP, THE FALLEN, THE *WNTY*.
 30 'APEP, THE FALLEN, THE *KRIW MNTY*.
 'APEP, THE FALLEN, THE AVERTED OF FACE.
 'APEP, THE FALLEN, THE *SB* OF *SB*.
 'APEP, THE FALLEN, THE FROWARD.
 'APEP, THE FALLEN, THE *HNRIK KSHR*.
 35 'APEP, THE FALLEN, THE *N*-SERPENT (?).
 'APEP, THE FALLEN, THE DEVOURER (?).
 'APEP, THE FALLEN, THE *TWR*.
 'APEP, THE FALLEN, THE *YB*.
 'APEP, THE FALLEN, THE EVIL-MINDED (?).
 40 'APEP, THE FALLEN, THE *HRRD*.
 'APEP, THE FALLEN, THE BROKEN.
 'APEP, THE FALLEN, THE SLAIN (?).
 43 THE DEPICTIONS OF THE ENEMIES WHICH ARE TO BE MADE ON A NEW SHEET OF PAPYRUS;
 44 THEY ARE TO BE FELLED ¹ AND CAST INTO THE FIRE.
 45 THERE SHALL BE MADE A SERPENT WITH ITS TAIL IN [ITS] MOUTH AND ITS [FACE] ¹ (TURNED)
 46 DOWNWARD, AND IT SHALL BE THUS INSCRIBED OVER ITS BACK: 'APEP, THE FALLEN, THE *BTW*-
 47 SERPENT'. MAKE ANOTHER; IT SHALL BE 'THE MYSTERIOUS OF WORDS'. ¹ MAKE OTHER IMAGES
 48 THEM; THEY SHALL BE 'THE CHILDREN OF REVOLT'. MAKE ANOTHER ¹ SERPENT WITH THE FACE
 OF A LION AND ITS FACE (TURNED) DOWNWARD, AND IT SHALL BE THUS INSCRIBED: 'ROARER' ¹

49 MAKE ANOTHER WITH THE FACE OF [.] AND IT SHALL BE THUS INSCRIBED: 'GRYWB. 1
 50 MAKE ANOTHER WITH THE FACE OF A CROCODILE, AND IT SHALL BE THUS INSCRIBED: H;W-N<
 51 HR-HR. MAKE ANOTHER 1 IMAGE OF A FOE WITH A BIRD-FACE, AND IT SHALL BE THUS INSCRIBED:
 52 WNTY. MAKE ANOTHER, 1 AN ANTELOPE BOUND AND FETTERED, AND IT SHALL BE THUS IN-
 53 SCRIBED: 'APEP, THE FALLEN'. 1 MAKE OTHER IMAGES OF FOUR FOES WITH BIRD-FACES AND
 54 WITH THEIR ARMS AND LEGS FETTERED 1 BEHIND THEM, AND THEY SHALL BE THUS INSCRIBED:
 'THESE ARE THE CHILDREN OF REVOLT.'

33 1 After this, praise Rē< and recite: O my father, lord of the gods, greatest of the Great Ennead,
 2 first primaeval one 1 of the gods, who created men, after whose coming into being all beings
 3 came into being; I am truly thy son of thine heart. 1 Divine is this heart which issued from
 4 thy shrine, praises come into being with thee, magic 1 making thy protection (?). How beautiful
 is that which comes forth from my mouth, for I am one excellent of counsels!

5 Come, O Rē<, behold 1 me with thine eyes; mayest thou praise what I have done. I fell 'APEP
 6 in his moment for thee, I destroy 1 him within his hell, while Ḥor-merti with his staff cuts off the
 7 heads of thy foes, the Butcher 1 with his great knife cuts to pieces the heads of those who rebel
 8 against thee, and the Devouring Flame, the fiery one, her fire burns up 1 his soul at his execution-
 block. But thy soul is joyful, joyful; it has sailed across the sky with a fair breeze.

9 Come, 1 look with thine eye upon what I have done to the body of 'APEP. His house is
 10 destroyed, his wall 1 ruined, his body destroyed in Yat-Pega. (But) thine heavens are stablished,
 11 thy cities firm-founded. Be thou enduring; 1 be thou flourishing; be thou hale; be thou youth-
 12 ful, youthful; rise, rise, shine, shine, every day. Mayest thou appear in the Bark, 1 thy heart
 being glad; mayest thou trust in thy children. (But) that 'APEP, the enemy, the *wmty*, the
 13 fierce-faced, 1 he has thought that thou wast (?) far from him, and he has planned evil at his
 14 execution-block; turn him back with his evil 1 on him. Ho, thou who ascendest from the
 horizon! The Two Lands are in joy, and thine heart, O Rē<, is glad every day, for 'APEP is
 15 fallen 1 into the fire, Neki is taken to the fire, and glad is the heart of Amen-Rē<, Lord of the
 16 Thrones of the Two Lands who dwells in Karnak, 1 for his foe is fallen under him. Rē< is
 17 triumphant over 'Apep—four times—Amen-Rē<, Lord of the Thrones of the Two Lands 1 who
 dwells in Karnak, is triumphant over his foe—four times—Atūm, Lord of Iden (?), is triumphant
 18 over his foe—four times—Thoth, 1 the efficacious of magic, lord of letters, is triumphant over
 his foe—four times.

It is at an end.

Commentary

32, 14. For *mnšd* 'mangled (?)' see *Wb.*, II, 89, 15.

32, 21. *ṁs* 'devourer (?)' is perhaps derived from *ṁm* 'to swallow'.



32, 23. *Sīdt* is possibly a writing of *sīty* 'pilferer', 'mutilator (?)', *Wb.*, IV, 32, 5-6.



32, 25. *Knmty* is perhaps connected with  'darkness'; 'the dark one' would be a very appropriate epithet for a storm-demon.

32, 29. On *Wnty* see the n. on 22, 22.

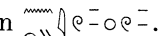

32, 36. *ṁm* may possibly be a variant of *ṁs* above, 32, 21.

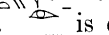
32, 39. *Wsy* is perhaps to be connected with  'to plan ill', *Wb.*, I, 244, 11.

32, 43. For the collective  'enemies' cf.  *Amada* 5. Note the Late-Eg. construction .

32, 46.  is doubtless a miswriting of the imperative , var. , which appears regularly in this text before *ky*.

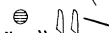
32, 47. On *ms(w) btš* see the n. on 24, 22.

33, 9.  is doubtless to be equated with , a late variant of ; for the sense of 'ruin', 'destruction' of buildings or lands cf. *Urk.*, IV, 386, 4; *Israel Stela*, 11, 26.

33, 17. On the place-name 'Idn see the n. on 25, 22.

FURTHER NOTES ON SOME EGYPTIAN FIGURES OF CATS

BY N. LANGTON

With Plates iii, iv

THE cat has been associated by Egyptologists so exclusively and for so long with the goddess Bastet that it is disturbing to find in our collection figures and groups which show that it was associated with other deities, including Osiris, Nefertēm, Bes and other dwarf-gods. Many of these are however difficult to identify, and the rarity of the pieces, and the wide range they cover, make the task the harder. Yet identification is most desirable in view of the possibility of a common origin. This article attempts little more than the presentation of material from our collection, which emphasizes very clearly the widespread importance of the cat in Egyptian life and religion; indeed a doubt seems permissible whether such range can be credited to any one divinity, and still less to a minor deity such as Bastet.

Our present material divides itself roughly into three classes:

A, in which a small cat is seated at the foot of a deity.

B, in which a cat forms part of a group containing a deity.

C, in which some cat feature is grafted on to another form of deity.

This classification by outward form is adopted for the sake of simplicity, as grouping by abstract ideas—life, death, pleasure, maternity, and the like—is too speculative at this early stage.

Before discussing the material it may be helpful to consider what other cat influences might be potent enough to rival or supplant Bastet herself as the origin of these figures. They are very few. Rēc, named in the *Book of the Dead* (Spell 17) as ‘the Male Cat’; ‘the cat of lapis lazuli’, and ‘the Great Cat’ mentioned by Professor Blackman in his article on the Papyrus of Nespeheran (*JEA* 5, 25); ‘the cat in the House of Hapt-Rēc (*Bk. Dead*, Sp. 125); ‘the cat within the house of Met’ (*Metternich Stela*, ll. 78–9), and the cat-headed mummiform figure on the cat’s sarcophagus at Cairo (cf. *ZÄS* 44, 97), seem to complete a list of which most of the names are mere shadows, perhaps with a common origin. Only Rēc emerges as powerful and catholic enough for real importance; but even so a few references in the literature (*e.g.*, Budge, *Gods of the Egyptians*, I, 272, 345; II, 297), and a few vignettes in papyri as the slayer of Apop, can do little more than stir the imagination.

CLASS A (Nos. 1–6)

A small cat seated at the foot of a deity

1. Cat-headed, human-bodied Bastet standing, wearing long patterned robe and carrying the sistrum, aegis, and basket. In front of her right foot is a small seated cat, facing the spectator, Pl. iii, 1. Bronze. H. 6.2 cm. Saite.

Although badly corroded, this figure is too rare and important to be omitted. Nothing material is affected. The figure is undoubtedly Bastet, but the secondary figure, the cat, is less easy to identify or explain. We know that Bastet was invoked in cat form (*JEA* 22,



1



2



3



4



5



6

EGYPTIAN FIGURES OF CATS

Scale 1:1.

116, 2, A), and that, as cat, she received priestly worship (*cf.* Pl. iii, 2),¹ but there is nothing to help us in this case to a choice among an incarnation, a *ka*-figure, a 'familiar', a temple cat, and some power quite distinct from Bastet; nor does the subordinate position of the cat help us. If it is an incarnation, duplication of divinity is involved. This seems to be exceedingly improbable unless perhaps the object was to show the goddess in her earlier form as cat, and in her later one as semi-human, when the Egyptians had come to see a blend of animal and human as a higher or more attractive conception of divinity. The fine bronze group in the British Museum (No. 12590), showing the semi-human Bastet with four kittens at foot, might be regarded as on a similar footing to our group; but that, I think, shows Bastet as a maternity deity, whereas our single cat is evidently one of a series connected with certain deities with whom, as will appear, a maternity motive seems out of place. That the cat here represents the *ka* of the goddess seems improbable in view of the physical differences, and there is no evidence to support the idea of a 'familiar'. A temple cat is another suggested identification, but, though such must have been a complement to cat-worship, and probably like the Apis bulls was used for oracular purposes, it is most unlikely that one would be shown at the feet of any deity save Bastet herself; nor, with her present, would one seem to be needed.

2. Leonine-headed goddess advancing; arms pendent, hands empty; wig and ruff; uraeus on head; in front of right foot a small seated cat, facing spectator. Behind is a ring for suspension. Pl. iii, 3. Faience, blue glaze. H. 4.3 cm. Saite or earlier.

3. Similar to No. 2, but the uraeus is lost and the goddess carries an aegis. Pl. iii, 4. Faience, blue glaze. H. 4.9 cm. Saite or earlier.

Until the leonine-headed deities have been identified with precision it may seem precipitate to claim these two figures as Bastet. Both, however, wear the uraeus (the fracture on No. 3 shows that one was present) and, since out of thirty-three uraeus-crowned, leonine-headed figurines with inscriptions which I have noted, no fewer than thirty bear the name of Bastet, there seems no reason to doubt this identification. Moreover, the goddess in No. 3 carries the aegis, which is peculiar to Bastet, so that the two figures supplement one another as evidence for the attribution.

The reason for the distinction between the leonine and cat-headed forms of Bastet is unknown, and it is curious that in faience, for wear as a personal amulet, the former was as common as the latter was rare. Perhaps the form of worship and the regalia worn differed according to locality or special festival. The problem of the cat's presence seems as far from solution as in the case of No. 1. It is very unfortunate that no inscribed group of this kind seems to be known.

4. Nefertēm advancing, wearing lotus head-dress and kilt, and carrying a falchion in his right hand. Before his right foot is a seated cat, facing the spectator. Behind is a ring for suspension. Pl. iii, 5. Bronze. H. 6.7 cm. Saite.

Nefertēm, the son of Bastet or, as some texts say, of Sakhmet-Bastet, links the cat with a male deity though one within the Bastet circle. He belongs by parentage and association to the solar gods, and if he can be regarded as a form of Rē, the cat may connect with the latter rather than with Bastet. He is also associated with Osiris (*cf.* No. 5).

5. Osiris standing, holding crook and flagellum; in front on right side a seated cat facing spectator. Behind is a ring for suspension. Pl. iii, 6. Bronze. H. 7.5 cm. Ptolemaic.

¹ Also from our collection. Bronze; H. 7 cm.; Bubastite (?).

Out of many hundreds of similar figures this is the only one I know of with the cat so placed. It brings the cat or the power it represents into close touch with the world of the dead. A similar conception seems to underlie a bronze group at Cairo, in which Osiris is enthroned between Nefertēm and Harpocrates, with a seated cat at his side and a kneeling worshipper in front, and also in the curious amuletic group No. 9. In addition to these, Professor Blackman (*JEA* 5, 26) mentions that the cat is connected somehow or other with the ceremonies of mummification, and records the occurrence of a cat-headed mummiform divinity.

6. Fragment of a group showing the feet of a goddess trampling on two prone captives; behind her left foot a seated cat looks over its shoulder as it turns its back on the scene. Faience, blue glaze. H. 3·7 cm. Bubastite.

This curious fragment was published in *JEA* 22, Pl. vi, 4, and p. 118, where the principal figure was identified as Bastet. It is included here as extending the series, and as an interesting variation of the normal type. The scene is as yet unexplained.

CLASS B (Nos. 7-11)

A cat forms part of a group containing a deity

7. Bastet, with cat's head, legs and tail, standing. She wears a short patterned tunic, and carries the three usual emblems (sistrum now lost); on her right stands a small figure of Bes playing on a lyre, and on her left a crouching cat bites the head of a bird. The group is placed on a low four-footed stool, the sides of which are inscribed with the names of Udjehōr and his mother. Pl. iv, 2. Bronze. H. 11·7 cm. Saite.

This group, apparently unique, suggests a ritual scene, and shows Bastet in a rare form, her aspect perhaps at some particular place or time. Unusual features are the short skirt, the way of holding the aegis, and the cat's legs and tail. Bes is frequently associated with her but the role of lyre-player is uncommon. Bird-eating cats are known as ornamenting the loops of sistra (Langton Coll., No. 239); they are found, too, in tomb paintings (*e.g.*, in the tomb of Raḥmose at Thebes), but the latter reproduces a domestic scene with the hope of perpetuating it, whereas our group and those on the sistra suggest religious significance, being perhaps copies of a divination scene in a temple, or of a ritual feeding of sacred cats.

8. Bes, standing, wearing a head-dress of four plumes pierced at the tops. He is nude and tailed, and plays on a long-handled lute. Knee-high, as supporters on each side, are seated cats, facing spectator. Pl. iv, 1. Bronze. H. 11 cm. Saite.

This adds another example to the Bes-and-cat combinations. The association may be due to the fact that both were pleasure-giving deities and were connected with birth and fecundity. The presence of two cats seems to rule out identification with any single divinity.

9. Leonine-headed goddess standing, wearing disk and uraeus; on each shoulder sits a cat, facing spectator, and on each side is a figure of the mummiform Osiris. Behind is a ring for suspension. Pl. iv, 4. Bronze. H. 3·9 cm. Ptolemaic.

This unusual amulet, like No. 5, connects the cat with Osiris; but here both god and cats are accessories rather than principals. The dominant figure with the disk and uraeus is presumably Sakhmet (I know of no inscribed figure with this head-dress that bears the name of Bastet), but her association with the cat is a puzzle unless, in some hidden way, a link between Bastet and Sakhmet is intended. The group belongs to a late period when fusions were a fashion.



1



2



3



4



5



6



7



8

EGYPTIAN FIGURES OF CATS

Scale 1:1.

10. An ape, or priest masked as an ape, seated on a stool and placing a circular disk on the head of a cat seated between its knees. The group surmounts the capital of a papyrus-column. Faience, blue glaze. H. 8.3 cm. Bubastite.

This piece was published in *JEA* 22, Pl. vi, 1, but is mentioned here as it introduces a new deity into the circle of the cat's associates. This deity is assumed to be Thoth, and it is curious that he and Bastet appear to be the only carriers of the sacred eye. The action suggests some ceremony of a solar nature. The Grenfell Collection (Lot 102) contained a group in bronze showing a seated cat faced by an ape.

11. Human-headed sphinx, with spotted cat body, seated; head turned to right; hair cropped in four heavy locks; tail on right side; between forepaws is a seated kitten, and another reclines on back. Behind is ring with square edges. Pl. iv, 3. Faience, blue glaze: hair and spots in black glaze. H. 1.9 cm. Bubastite.

In early times the sphinx in leonine form represented the King, and in later ones the god Harmachis. The presence of young shows our sphinx to be feminine, and as no lion-cub groups are known, and as this one duplicates exactly some of the cat groups shown in *JEA* 22, Pl. vii, 3, 12, 14, the combination is certainly with the cat. Probably the amulet is a maternity one, but how it originated is not known, unless perhaps the Bubastites, who seem to have been fertile in new ideas, recast the sphinx. A small amulet (No. 11865) in the British Museum shows a sphinx guarding its kitten in true cat fashion.

CLASS C (Nos. 12-15)

Some cat features grafted on to another form of deity

12. Cat-headed dwarf standing; nude, tailed and straddle-legged; wig with two heavy plaits; hands clenched and pierced for the insertion of objects (lost). Behind is ring with square edges. Pl. iv, 6. Wood. H. 6.4 cm. Bubastite or earlier.

A cat-headed Bes was my first thought for this figure, but the wig is an alien element, and the position of the hands is more suggestive of captive snakes than of the knives which Bes sometimes carries. Snakes indicate Ptah-Sokar, of whom small cat-headed bead figures are known, but neither the tail nor the wig is among his peculiarities. Mr. Alan Shorter ingeniously suggests kinship with one of those dwarf figures who appear nude, wigged, and straddle-legged, and with snakes, on some of the ivory wands of the Middle Kingdom (cf. *PSBA* 27, 130ff., 297ff.; 28, 33ff., 159ff.). These wands are judged to be horoscopic, and cats are sometimes figured on them. Dwarf gods are often associated with the underworld, but the evidence is, I feel, too slight as yet for plausible identification.¹

13. Cat-bodied creature with the face and breast of a falcon. Pl. iv, 7. Faience, green glaze. H. 1.7 cm. Saite.

A larger piece might be more convincing, but this one does not stand alone, for a faience figure in the British Museum (*ex* Bethell Sale, Lot 239) shows the same combination of cat and falcon with complete clearness: the shape and poise of the head, the prominent breast and thin legs being unmistakably those of a falcon. There are a number of combinations with falcon heads which show the importance of the bird, and if, in this case, the falcon element could be regarded as Rē it might show the god in a double role of falcon and male cat.

¹ A very interesting link between Bastet and the dwarf world is to be seen in the Papyrus of Dirpu, a singer of Amūn (*Anc. Egypt*, 1914, 29). This shows the deceased being led by the cat-headed Bastet and accompanied by a bitch-headed dwarf carrying knives and a snake. Our wooden figure would make a good understudy for this strange creation.

14. Cat-headed animal seated ; full breasted ; on each shoulder a protuberance (ends lost). Pl. iv, 5. Bronze. H. 2·7 cm. Ptolemaic.

In poise, vigour, and character this fantastic creation recalls the bronze Cerberus in the Museum of Alexandria (*Guide*, Fig. 34) and so suggests that the lost terminals of the protuberances may have been subsidiary heads of a feline nature. Fantastic combinations are found as early as the Twelfth Dynasty in the Tombs of Beni Ḥasan (*e.g.*, Tomb No. 3), but this vigorous little creature seems to fall into a more significant category, and suggests Greek blood. Alternatively the protuberances may be additional breasts, showing us a 'Great Mother' deity similar to the Ephesian Diana, or again we may have a new version of the sphinx according to Alexandrian fancy.

15. Cat- or lion-headed goddess seated ; arms crossed on breast ; in each hand a hoe. Scarab (?) on head. Pierced for suspension. Pl. iv, 8. Faience, green glaze. H. 1·9 cm. New Kingdom (?).

No similar figure is known to me of this *shawabti*-type. It is difficult in so small a piece to decide whether a ruff is indicated or a scarab is present, but my own feeling is that there is a scarab and no ruff. If so, Bastet would be indicated, as cat-headed representations of her with scarab head-ornaments are known, and we could then see this figure as a further link with the underworld. The shape of the hoes indicates an early date.

I am afraid I must admit my inability to come to a definite conclusion about these pieces. I can find no common denominator, but, generally speaking, Bastet would seem to be the likeliest inspiration. In some of the pieces, however, it seems improbable that she is present. Is it possible that behind our puzzle are the male and female principles, and that the female, as time passed and civilization mellowed, usurped, little by little, much of the power of the male, leaving him to be recalled occasionally as a tradition of an old heroic age? I am far from urging this, but it is perhaps worth keeping in mind until more evidence comes to hand.

THOUGHTS ON THREE RECENT ARTICLES

By G. A. WAINWRIGHT

I

CAPART, GARDINER, and VAN DER WALLE's *New Light on the Ramesside Tomb-Robberies* appeared in *JEA* 22, 169-93, including a full study of the implications of the text of *P. Léopold II*. Thorough as these are, they will bear some amplification, which it is proposed to supply here.

The text forms part of the inquiry into the tomb robberies, and Gardiner, surprised at their apparent strangeness, thinks the depositions might even be faked, and further marvels 'at the gusto with which Amenpnüfer recounts his thefts' (p. 187). But this is explained by the nature of the report. The papyrus is of course not a verbatim report of the proceedings, but a *précis* giving the gist of the endless cross questions and crooked answers by which some approximation to some facts got into writing. For instance, no man comes into court and states baldly 'I committed this, that, and the other crime'. Nor does he call himself a thief; that of course is the clerk's designation of the accused. In being a *précis* this report is exactly comparable to the modern *procès-verbal* of the police-stations in Egypt, which the accused is made to acknowledge with his seal.

The two protagonists in the text are Pesiūr, Mayor of Thebes on the eastern bank of the Nile, and Pwerco, Mayor of the western bank. The robberies had taken place within Pwerco's jurisdiction, but he had not reported them, and Pesiūr had laid a complaint against his brother mayor. Pesiūr was on the Great Tribunal, yet he 'did not find much favour with his colleagues' there (p. 186), who had to make the resulting inquiry. No, indeed! They no doubt looked upon him as a troublesome disturber of the peace. Indeed, they 'appear to have been unanimous in resenting the aspersions implicitly cast upon the administration of Pwerco' (p. 186). Quite so! Not only for the reason given above, but no doubt for fear that some of them themselves might also become implicated. Hence their joy (p. 188) when nothing much transpired at the official inspection. Furthermore, the value of the official tour of inspection will be evident to any one knowing the district. The commission crossed the river in the afternoon of the 19th (p. 188). It had to get out to the edge of the desert, where it inspected Dirā' Abū 'l-Naga on the north and the Tombs of the Queens to the south of the Necropolis. It was a great deal of ground to cover, yet it claims to have done it, and one of its members, Nesamūn the Royal Butler, was back again in Thebes on the eastern bank in time to see the demonstration that evening. Quick work! We may well believe that the demonstration was whole-hearted which was staged by 'the controllers and sergeants and work-people of the necropolis, together with the heads of police, policemen, and staff attached to the royal tomb' at the instigation of Pwerco and the commission (p. 188). They and their administration were vindicated, they were all 'good men'—and everything could go on as before.

Pesiūr, the complainant, was not taken by the Vizier and the Royal Butler on their official inspection (p. 188). Surely, because he might keep on pointing out uncomfortable details, which it would be more convenient for all parties to overlook. Such was Peikhal's

refusal to acknowledge the plundering of a tomb which a later inquiry was to prove had been smashed to bits (p. 188).

One feels sure that news must have come back to Pesiūr that the Vizier and the Royal Butler had gone to the house of his enemy, Pwerō. The going of the authorities to some one's house is accepted as important evidence in modern Egypt as to which way the wind is blowing. But all the same Pwerō was no doubt given a very nasty time, and reproached in some such terms as 'How is it, O Pwerō, that robberies take place in your district? The Mayor of Thebes is a good man, he would not tell lies, and if robberies had not taken place where did such and such gold come from?' And so it would have kept on and on, until the reproachers were induced to stop it.

What inspector is not well used to such behaviour as Peikhal's? The known and self-admitted robber is only able to identify two places as those which he had entered, and those perfectly harmless open ones: an unoccupied tomb and a workman's hut! No doubt he was very apologetic and voluble, admitting frankly that he had been very wrong in entering any unauthorized place even such as these, and that, hence, their excellencies were more than right in calling him a thief, and that he would remember all his life the words of wisdom with which they had honoured him. But anything worse than this? Never, no never!

Pwerō is stated 'to have laid the information upon which the Tribunal proceeded to act' (p. 186). No doubt he did, but only when Pesiūr was getting too dangerous.

Pesiūr had named ten tombs, including that of Amenophis I, in his accusations, but the commission of inspection reported only one as rifled (p. 187). No doubt he suffered many reproaches for this error, and much indignation was poured on his head as an unprincipled liar. Meanwhile, every one would have been rolling out sonorous phrases about the excellence of the perfection of the beauty of truth. But of course Pesiūr was only repeating hearsay, which, while reliable as to generalities, is utterly unreliable as to details—many a rogue has been able to escape by exposing the untruth of a detail or two. On the other hand Pesiūr may have been making the wholesale accusations, some of which may be true but cannot be substantiated, with which the *fellāḥ* so often spoils his perfectly good case.

The unfortunate robber Amenpnūfer did the work, but was a poor man. He got nothing out of it himself but the labour, anxiety and torture at the trial, and final punishment. After being imprisoned in the first instance, he had to deliver up his share of the plunder to obtain his release. Fortunately for him he was able to recoup himself for his losses at the expense of his companions, but was finally brought to trial and punished (pp. 171, 172).

Naturally Amenpnūfer returned to his old practices after his first imprisonment (p. 188), supposing no doubt that the affair would blow over, as others were continually doing. His attitude before the Great Tribunal was entirely natural and justifiable: 'Why pitch on me rather than on any one else? I am no worse than all the others.' Where there is little justice luck comes into play, and no doubt all his friends and relatives said 'Ah, poor Amenpnūfer, he has no luck'. The attitude, not of actively being better than others, but of passively being no worse than they is common among the *fellāḥīn* in Egypt to-day. In ancient times it inspired the whole of the 'Negative Confession', which rolls on and on repeating 'I have not done' something wrong, never 'I have done' something good.

The account of the demonstration of the exultant party is marvellous (p. 189). The affair can easily be visualized and the abuse which must have been bandied about by the crowd can be paraphrased in colloquial Arabic with plenty of such remarks as '*A-a-a-h-h-h! ibn el kelb! kân 'auz yikhrabna khālīš! kân 'auz yermīna fi 'd-dāhyah! lākīn eḥna nās ṭayyiba! Il-wazīr rāgīl gada! 'ārīf mīn 'anduh il-ḥakk! A-a-a-h-h-h! yīn'al abūh! &c., &c., &c.*' Also Userkhōpesh's remarks (p. 189) are true to type with their fatuous high morality and their far-

flung generalization. 'All the kings, &c., are intact', though at least one king and several lesser people were already proved to have been plundered (p. 187). They are protected by 'the sage counsels of Pharaoh, &c.,' and everybody who heard him echoed his sentiments, though knowing full well that it wanted much more than that to do it. Of course the implication is that there is no need for such as you to make a fuss, and in any case you prove to be a liar. But Pesiūr having gone so far, and like all the crowd knowing himself to be right in general if not in every particular, threatens to carry it higher. Alas! such action only involves the unfortunate in endless disputes, makes him incur the enmity of every one as a nuisance, and finally ruins him. As a matter of fact Pesiūr only got himself 'properly ticked off' in public by the vizier two days later on one inaccurate detail (p. 190). After this nothing more is heard of him, while the delinquent, Pwerō, Mayor of the West, continued in office for at least seventeen years longer (p. 190). But let no one's sympathy go out to Pesiūr as the one honest man suffering for conscience' sake. No doubt it was something personal that moved him, a grudge, a desire to get more of the loot for himself, or possibly to gain credit with his superiors, though this is hardly likely in view of their attitude towards the whole affair. Again, Pwerō, Mayor of the West and chief sinner, now that the die is cast comes out as the faithful upholder of right against his rival Pesiūr, Mayor of Thebes. In righteous indignation at some breach of official etiquette and at the accusations that were levelled against him, he writes 'I have reported them to my lord since it would be a crime for one in my position to hear accusations and to conceal them' (p. 189). Assuredly he added to his friends 'How can the world go on if such iniquity is not stopped?' Yet he never reported the really serious things, which were the robberies going on in his district. Nor does he even 'know the purport of the great accusations, &c.', which brings an echo of the complaint of injured innocence 'Wallāhi! mā a'rafshi wala hāgah 'alēh'. But Pwerō is 'reporting them to my lord, and my lord shall get to the bottom of these accusations, &c.' (p. 190), loading all the trouble on to his superior, who would have been worthy of pity if he had not so evidently been in it up to the neck. Note the breach of etiquette which formed the basis of the complaint. It was that the information had been laid before that member of the Great Tribunal, Pesiūr, Mayor of Thebes, who would be likely to take it up. The complaint is that it should have been laid before a greater man, the Vizier. This would have been convenient for Pwerō, as the Vizier happens to have shown himself Pwerō's 'friend'.

But mā 'alēsh, every one has been galvanized into activity and trouble to do their duty in an unpleasant situation. Much inquiry has been made, and it is true that some trifling delinquencies have come to light; but how shameful to have made such a fuss over so small an affair, and to have tried to destroy the character of a 'good man'; after all the world is not perfect, and 'mistakes' (on this occasion the robberies) will always occur. It is very indecent to wash one's dirty linen in public, &c. Some wretched starving workmen have been severely punished, the public men and their administration have been justified, and the 'calumniator' reprimanded, even though in a high position. Every one sinks back feeling he has done his duty, and will one day urge his energy on this occasion when looking for some advancement—and everything goes on just as before. Only, it will be up against Pwerō that robberies did take place under him, in case a stick should ever be needed, even twenty, thirty, or forty years later, with which to beat him.

Finally, the necessity should be urged for getting a right perspective before such complications can be fully appreciated, or the difficulties of life under such uncertain conditions be understood. There must be many books which would supply the suitable background. One which happens to have served this purpose for the present writer is Captain H. Cox's *Journal of a Residence in the Burmhan Empire*, for it gives his day-to-day experiences at the

capital in 1797. Not to waste an inquirer's time it may be said that pp. 53-5, 182-4, 263-5, and 310 to say 405 would prove especially instructive.

II

In volume 23 of the *Journal* two more articles have appeared, which in their turn lend themselves to illustration from modern Egypt.

The first is Hemmy, *An Analysis of the Petrie Collection of Egyptian Weights*, which appears on pp. 39-56. The extraordinary confusion in ancient Egyptian weights would appear to the uninitiated to make commerce almost impossible. Yet exactly the same state of affairs exists in Egypt to-day, where one soon gets used to it and ceases to notice it. Thus, the *dirā'*, *mitr*, and *yardah*, are all used for measurement, and work happily side by side, and the differences between them, and consequent differences in prices quoted, are well understood. The *dirā'* is of course the cubit, and is in constant use all over the country for buying lengths of material. As it represents the length of the forearm to the finger tips plus the length again to the knuckles, it is as well to get a long-armed man to help you to buy your calico. You can sometimes, I understand, persuade the dealer not to use his own measure. Otherwise for these transactions the *mitr* and sometimes the *yardah* are used, and, as their names imply, they are the metre and the yard respectively. Naturally they are more in use in the towns than in the country.

Both the *ratl* and the *wikḳah* are the regular weights, though they bear no relation to each other; the *ratl* being just a fraction under 1 lb., whereas the *wikḳah* is just 2½ lb. In the Europeanized cities one can generally buy by the kilogram also, if so desired.

For the measuring of small plots of land for village purposes the *kaṣabah* is a very usual standard. But you can also measure in *dirā'*, six and a half of which are practically one *kaṣabah*. The small difference is marked at the end of the palm-stick measuring-rod.

Things are more complicated as regards money. In the Upper Country, if a man is talking at his ease, and not taking pity on the *khawāgah's* supposed ignorance, a *riyāl* means 15 piastres, and if you mean the 20 piastres of the Government coin, which is known to excavators, you must specify *riyāl maṣrī*. Similarly, the coin known to Europeans as 2 piastres, *kirshēn*, is commonly called *tumn*, i.e. one eighth of a *riyāl* once reckoned at 16 piastres. In the Ṣaḳḳārah district the old Turkish coin, the *pāra*, pronounced *bāra*, still passes as currency. There are forty of them to the piastre, so actually the whole country reckons in them under the name *faddah*, when it speaks of 'ashrīn (20), sittīn (60), and miyah (100) *faddah*, which is the usual way of referring to the half, one and a half, and two and a half piastres. Except with *miyah* the word *faddah* is regularly dropped off. Not unnaturally, like our own thrummer, tanner, and bob, most of the coins have their nicknames, such as *abū khamsah*, *ṣāgh*, *bēdah*, *ta'rīfah*, *niklah*, &c.

Another complication exists between Cairo and Alexandria. While at Cairo *kirsh* means the piastre of ten millièmes, at Alexandria it means that of five millièmes, commonly known to Europeans as the piastre and half piastre, respectively.

The future student of antiquity may one day be troubled by the inscription which the coins bear, or used to bear. Each coin states that *ḍuriba fī Maṣrī* 'it was struck in Cairo', though actually on research he would find that it was struck abroad—in Switzerland I believe.

At Port Sa'id the coins of almost all countries are current and their values in millièmes are well-known. During the War an extra complication was introduced in the form of the Indian rupee, which passed everywhere at sometimes six and sometimes six and a half

piastres. In Syria before the War things were far worse. Not only the official Turkish coins, but those of every European country and also those of most Oriental countries were current. Thus it was impossible to get the exact change. The seller could only see what coins he had in the till, and calculate with paper and pencil how nearly he could get to the correct sum. Though no doubt the system usually worked against the buyer, on one occasion it provided the present writer with a return ticket from Beyrūt to Jebel (Byblos) for almost nothing. Scarcely believing the booking-office clerk could have made a mistake in his change so heavily against himself the purchaser had his suspicions confirmed by a fellow passenger, who was loud in his congratulations. All through Syria the *mejidiyah* had five different values, varying as to whether you were dealing with the Post Office, the Revenue, the merchants in the market, &c. But this was not all, for in every town each of the five differed from what it had been in the town you had just left. On arrival the first thing to do was to inquire the local values.

Money, however, is not everything to the Egyptian countryside, and the extent to which barter plays its part in village life is perhaps hardly appreciated by students. An egg or two, a couple of onions, a cupful of corn, a pigeon, will buy at the local shop the household's small requirements, such as a few needles, a reel of cotton, a fill-up of the paraffin lamp, or a few sweets for the children. The schoolmaster is paid in loaves and perhaps a few piastres now and again, as is the water-carrier. Even the comparatively smart chauffeur of some well-to-do landowner may get his salary in so many *ardabb* of corn at harvest-time.

The *kēlah* is a measure for flour and small quantities of corn &c., and this is smaller round about Şakḳārah than in the Upper Country. This in the eyes of the Southerner is yet another proof of the superiority of the South over the North.

Yet again Egypt uses three calendars without trouble. They are the Arabic, or lunar, for religious purposes; the Coptic, or ancient Egyptian, for farming; the European or Gregorian, for Government and business purposes in dealing with *khawāgāt* (Europeans and Americans). Most men who can read expend half a piastre on an almanack, and the amount of interest taken by every one in the calendar is astonishing to the town-bred European. The latter's interest in it does not go much beyond looking for the date at the head of his newspaper, or looking on a calendar to find the date of an appointment for Tuesday three weeks.

Thus it will be seen that a great variety of weights and measures can exist side by side, and is quite workable in a society that is only loosely organized, is not pressed for time, and does not weary itself with too exacting a precision.

The second article is to be found on pp. 62-75. It is entitled *ΜΕΡΙΣΜΟΣ ΑΝΑΚΕ-ΧΩΦΚΟΤΩΝ: An Aspect of the Roman Oppression in Egypt*, and in it Mr. N. Lewis discusses how the collection of taxes led to the ruin of the land under the Romans.

Similar extortionate taxes and their brutal extraction produced the same result in Isma'il Pasha's time. There is many a poor man in Egypt to-day whose grandfather or great-grandfather had possessed land and had been comparatively affluent. However, the taxes and the extra payments consequent upon the collection of them became so impossible that the tax-gatherers had to resort to torture to extract them. The favourite means were, of course, the bastinado, but also the *khazūk* which was worse. The result was that many a man fled from his land, saying it was better to starve in peace than to starve and be 'killed entirely' because he was unfortunate enough to own land. One is told that people were reduced to fighting with the cattle for such green food as grew naturally, and that a man was lucky to possess as much as a rag round his middle. Those who had sufficient character simply became robbers living on the edge of the desert. Hence the population was in a state

of flux, and a great proportion of families have not been in their present villages for more than a hundred years, and will tell you that they came from elsewhere. An extreme case came to the present writer's knowledge when we were excavating at Mēdūm in 1910-11. Near here is a village, Abū 'n-Nūr if his memory serves him aright, whose ancestors had come all the way from Ḳuft in the south. Our Ḳuftī workmen were greatly excited when the facts came to light, and visits of ceremony were made by both sides to cement the friendship of the new-found relatives. Similarly the ancestor of a well-known family in one of the Abydos villages had fled from Denderah.

Mr. Lewis does not say whether in Roman times impostors went round forestalling the official tax-gatherers, but such frauds, one is told, used to be perpetrated last century. Hence the *fellāh* had often paid taxes several times over. Such a state of affairs finds its natural consummation in the blowing to bits of Old Beni Ḥasan a few generations ago by the Government, just to teach the people that unwillingness (?) to pay taxes was no good.

THE ELECTION OF THE METROPOLITAN MAGISTRATES IN EGYPT¹

By A. H. M. JONES

PAPYROLOGY tends too much to be divorced from the study of Roman history; not unnaturally, since papyrologists have their hands too full already to wish to venture into an alien field, and the students of Roman history are deterred by the technicality and the profusion of papyrus documents. But it is plain that many problems of papyrology will become clearer in the light of what we know of the constitutional law and administrative procedure of the Roman Empire, and that, on the other hand, our rather meagre knowledge in these fields will be immensely amplified by the interpretation of the papyri. This paper is an attempt to correlate what we know of the election of city magistrates in the Roman Empire generally, and in particular in the Greek East, with the evidence of the papyri on this question.

I approach my problem from the general practice in the eastern provinces. There is no dispute here as to the main principle, that the magistrates (*ἀρχοντες*) of each city were elected by its people (*δῆμος*). Of the procedure we know virtually nothing, but I would wish at this stage to venture a hypothesis which will I hope be justified later in this paper. There can be little doubt that democracy was in the Hellenistic East the dominant form of city government, and that the particular form of democracy generally adopted was modelled, directly or indirectly, on the constitution of Athens. It is, therefore, not unreasonable to apply what we know of Athenian constitutional procedure to the Greek cities of the East in general. We know from Aristotle's *Constitution of Athens* that the election of magistrates in the assembly was preceded by a *προβούλευμα* (Arist., *Ἀθ. Πολ.*, 44, 4). We do not know what the content of this *προβούλευμα* was, and it may have varied. It may have been simply to the effect that the people elect the magistrates, but it may, and probably often did, propose a number of names to the people. In the procedure of election at Athens names were first proposed (*προβολή*) and then voted upon (*χειροτονία*). Proposal of names often took place in the assembly (Dem., xviii, 149, *προβληθεὶς πυλάγορος οὗτος καὶ τριῶν ἢ τεττάρων χειροτονησάντων αὐτὸν ἀνερρήθη*, Aesch., *Fals. Leg.*, 18, *χειροτονουμένων δὲ τῶν δέκα πρεσβέων ἐγὼ μὲν προεβλήθην ὑπὸ Ναυσικλέους, Δημοσθένης δ' ὑπ' αὐτοῦ Φιλοκράτους*), but Plato in the ideal city of the *Laws*, which clearly borrows much from Athens, envisages the normal procedure as the presentation to the people of a list of candidates, to which members of the assembly may make additions, and then a vote on this possibly augmented list (Plato, *Legg.*, 755, CD). The role of the council (*βουλή*) is likely to have become more important when its character was remodelled by the Romans, and I suggest that under Roman rule the normal procedure in the cities of the East was *προβολαί* in the *βουλή*, a *προβούλευμα* proposing to the *δῆμος* the names of candidates, the possibility of further *προβολαί* in the *ἐκκλησία*, and finally *χειροτονία*.

I enter Egypt via Alexandria. Alexandria was without doubt a city, though in one important respect it was incomplete; it had no council. I do not see, however, that this deficiency has of necessity any bearing on the other elements of its constitution, its magistrates and its people. In a normal Greek city no *ψήφισμα* was valid without a *προβούλευμα*, but

¹ This article is in substance a paper read at the Fifth Papyrological Congress at Oxford, 1937.

the magistrates and people of Alexandria could pass *ψηφίσματα*, as Claudius' letter shows (Bell, *Jews and Christians in Egypt*, p. 23, l. 20). Even therefore if, as I believe, a *προβούλευμα* was necessary in a normal city before the election of magistrates, in Alexandria it would not have been so. *Prima facie* then, since Alexandria was a city, had magistrates and people, and was capable of dispensing with a council in legislation, it would seem likely that, despite the absence of a council, its magistrates were, according to the universal practice, elected by its people. Direct evidence on this point is scanty, but it does not, I think, contradict my hypothesis. Claudius in his letter to the Alexandrians treats the question of the civic magistrates as a domestic concern of the city (p. 24, l. 62, *ὑπὲρ δὲ τοῦ τὰς πολειτικὰς ἀρχὰς τριετὶς εἶναι καὶ πάνν ἐμοὶ καλῶς βεβουλευσθαι δοκεῖται*, i.e. *δοκεῖτε*). These words, I think, rule out the possibility that the magistrates were nominated by the imperial government. His allusion in the next few words to the examination which magistrates had to undergo on giving up office—*ὃ γὰρ ἀρχόντες φόβωι τοῦ δώσειν εὐθύνας ὧν κακῶς ἤρξαν μετριώτεροι ἡμῶν προσενεκθήσονται τὸν ἐν ταῖς ἀρχαῖς χρόνον*—more definitely suggests popular election; this *εὐθύνη* was part and parcel of the democratic system of the magistracy. Claudius' words are perhaps compatible with selection by lot. But this would be most unusual at this date, and the emperor's decision *τοὺς δὲ νεοκόρους τοῦ ἐν Ἀλεξανδρείᾳ ναοῦ ὃς ἔστιν τοῦ Θεοῦ Σεβαστοῦ κληροτοῦς εἶναι βούλομε καθὰ καὶ ὃ ἐν Κανόπῳ τοῦ αὐτοῦ Θεοῦ Σεβαστοῦ κληροῦνται* (p. 24, l. 60) carries the implication that this method was not the normal procedure.

More impressive to my mind than these passages is the general tone of the 'Acts of the Pagan Martyrs'. In these documents the magistrates of Alexandria—the gymnasiarch in particular—are portrayed as popular champions, the representatives of the city in its struggle against Roman tyranny. It does not seem very likely to me that men of the stamp of Lampon and Isidore were nominated to their posts by the government which they so bitterly attacked, and their prestige as popular heroes is more understandable if they were the elected representatives of the people.

I now proceed to the metropoleis of Egypt. We find in each of them from the early years of the Roman occupation a body of magistrates (*ἀρχόντες*), in externals analogous to those of Alexandria. The resemblance is, I think, too close to be accidental. We find both in Alexandria and in the metropoleis the same series of posts. The majority of them are, it is true, common to the Hellenistic world, but this particular selection is peculiar, and most peculiar—to my knowledge confined to Egypt—is the title of the head of the board, *ἐξηγητής*. The additional title of *ἀρχιπρύτανις* which is once given (at the City of the Arsinoites, P. Tebt., 397) to the *ἐξηγητής* is also suggestive. It implies that the proper designation of the metropolitan magistrates, normally given the vague style of *ἀρχόντες*, was *πρυτάνεις*, and we know from other documents (P. Oxy., 477, P. Tebt., 317) that the *ἐξηγητής* of Alexandria stood at the head of a body of *πρυτάνεις*. These facts suggest that Augustus (under whom the metropolitan magistrates first appear; the earliest datable metropolitan *ἐξηγητής* occurs in 5–4 B.C. in P. Oslo., 26) introduced into each metropolis a board of magistrates modelled on that of Alexandria.

Were these magistrates, as I take those of Alexandria to have been, popularly elected? An objection fatal to this hypothesis would be that in the metropoleis there was no *δῆμος* to elect them. To this I reply that a document of the reign of Antoninus Pius (P. Oxy., 473) records a decree passed by the *ἀρχόντες* and *δῆμος* of Oxyrhynchus. The document is clearly official and implies the official existence of a *δῆμος*; the association with the *δῆμος* in this decree of *Ῥωμαίων καὶ Ἀλεξανδρέων οἱ παρεπιδημοῦντες* is, I may note, no derogation of the authority of the *δῆμος*; in many decrees of Greek cities 'the resident Romans' are coupled with the 'people'.

Of whom did this δῆμος consist? I am inclined, in company with other scholars, to connect its creation with the registration of οἱ ἀπὸ μητροπόλεως and οἱ ἀπὸ γυμνασίου, which seems to have been instituted in the reign of Augustus, probably in A.D. 4–5 (Van Groningen, *Le Gymnasiarque des métropoles de l'Égypte romaine*, pp. 39–40). The creation of two grades of quasi-citizens in the metropoleis seems again to have been inspired by the example of Alexandria. There were, we know, in the reign of Augustus two grades of Alexandrian citizens, those who were simply Ἀλεξανδρεῖς and the more select body who were enrolled in the tribes and demes (Schubart, *Archiv* 5, 81 ff.). What were the privileges of this more select class is an obscure question, but it has been suggested that they alone possessed the *ius suffragii*, or perhaps the *ius honorum*. In the metropoleis the *ius honorum* at any rate seems to have been confined to the corresponding class of οἱ ἀπὸ γυμνασίου. The analogy between the two is perhaps closer yet. In the metropoleis the distinguishing mark of οἱ ἀπὸ γυμνασίου was the right, which was hereditary, to become members, through the ἐφηβία, of the gymnasium. In Alexandria the ἐφηβία seems to have been the avenue to the possession of full citizenship. I may cite Claudius' letter once more (p. 24, l. 53): ἅπασιν τοῖς ἐφηβευκῶσει ἄχρει τῆς ἐμῆς ἡγεμονείας βαίβαιον διαφυλάσσω τὴν Ἀλεξανδρέων πολιτείαν ἐπὶ τοῖς τῆς πόλεως τειμείοις καὶ φιλανθρώποις πάσει. This sentence seems implicitly to distinguish a citizenship 'with all privileges and concessions' from ordinary citizenship, and implies that access to the former was controlled by the ἐφηβία.

To return to my theme, my suggestion is that Augustus created in each metropolis a civic organization analogous to that in Alexandria. He instituted a body of magistrates and registered two bodies of quasi-citizens, a select group from which the magistrates were to be elected, and a larger body which had the right of electing them. It may reasonably be objected that this construction is entirely hypothetical. What positive evidence is there that the metropolitan magistrates were elected? Does the evidence which exists on the method of their appointment tally with this hypothesis? There is no direct evidence of popular election. But this is not surprising in view of the paucity of our documents and their relatively late date. On the other hand I hold that the procedure of appointing magistrates as depicted in the papyri is the vestigial remnant of what was once a popular election and cannot be explained otherwise.

In the election of magistrates, as in any normal electoral procedure, there were two stages, the proposal of candidates and the voting. But it is obvious that the second stage would become superfluous if in the first stage only so many candidates were proposed as there were places to fill; I need hardly remind my readers that to-day no vote is ever taken in the elections to many bodies, such as boards of directors or committees of societies, whose members are theoretically elected by popular vote. The cities of the Roman Empire seem early—though how early it is difficult to say—to have reached this stage in the degeneracy of democratic institutions, and then to have passed to the second, when it became difficult to find enough candidates to fill the places. In the Latin West things had, it seems, already come to this pass when Domitian's chancery framed the constitution of the *municipium Malacitanum*. For in that document (Dessau, 6089) it is specified that should an insufficient number of candidates make their *professio* to the magistrate holding the *comitia*, the said magistrate should post up the names of so many persons as are required to fill the vacancies, and that these persons may in their turn nominate each one other, and these again each one other, and that all persons so nominated should be deemed to have made their *professio*. This elaborate procedure, which was probably intended not so much to maintain the vitality of the elections by presenting a choice to the electorate as to prevent unfair discrimination by the presiding magistrate in his selection of candidates, does not seem to have had a very long

life even in the west, and there is no evidence that it was ever applied in the east. But some procedure similar in essentials must have been applied universally. The essential point is of course that, if candidates failed to come forward voluntarily, persons might be nominated as candidates against their will. Many legal texts which speak of immunity from *honores* prove that candidature for office was already frequently, if not normally, compulsory by the middle of the second century A.D.

The popular election of magistrates had thus by this period come down to securing a sufficient number of candidates, by voluntary offers if possible, otherwise by moral suasion, in the last resort by nomination (I use this term in its technical Latin sense). The first stage in the electoral procedure, the proposal of names, had, that is to say, become the essential part. There might follow a vote of the people, approving the list submitted to them, but this was a pure formality. It is interesting to note, however, that as late as A.D. 326 'populi quoque suffragiis nominatio in Africa ex consuetudine celebratur' (*Cod. Theod.*, XII, v. 1); forms die hard.

The legal texts unfortunately do not give any clue to the development of the procedure of nominations; they date from the third century at the earliest and depict the system in its complete form. And they present but a fragmentary picture even of the developed system. It will be as well, however, to summarize the information they give. It appears from them that nominations were normally made at a session of the council—this point, I think, confirms my hypothesis about early electoral procedure made at the beginning of this paper. For the early third century I may quote Ulpian, who says (*Dig.*, XLIX, iv, 1, §§ 3–4) 'solent plerumque praesides remittere ad ordinem nominatum ut Gaium Seium creent magistratum . . . sed et si praeses in ordine fuerit, ut fieri adsolet, cum ab ordine crearetur quis . . .'. I may say in passing that I question the constitutional accuracy of Ulpian's language; in effect the council did elect, but in law, I think, it drew up a list of candidates. The reason why it was important that nominations should be made in council is implied by Diocletian to have been to secure them due publicity; *Cod. Just.*, x, xxxii, 2, 'Observare magistratus oportebit ut decurionibus solemniter in curiam convocatis nominationem ad certa munera faciant eamque statim in notitiam eius qui fuerit nominatus per officialem publicum perferre curent'—it may be noted that Diocletian's use of constitutional terms is more exact than Ulpian's. This point is made more explicit by a later constitution: *Cod. Theod.*, XI, xxx, 53, 'Libellis vel edictis factae citra consilium publicum non valeant nominationes'.

It is assumed throughout the texts that nomination (in the strict sense) was universal; every magistrate, even if he had consented to hold office, had his nominator behind him. A person nominated was deemed to assent to his nomination, unless he entered a legal appeal within the statutory period, and was obliged to serve unless he could prove legal exemption or at any rate satisfy the governor that he had been unfairly selected. On the other hand, the nominator took a risk in proposing a name, for he was held surety for his nominee, whether the latter assented or not. In these circumstances it is obvious that no one would nominate who had not a pressing motive for doing so, and in some cases it seems to have been difficult to secure nominations; Ulpian (*Dig.*, *loc. cit.*) records that not infrequently the governor had to intervene, himself naming a particular person for a given office. The legal texts do not make it clear whether any one had an obligation to nominate. The constitution of Diocletian cited above seems to imply that *magistratus* had to nominate to *munera*, and a constitution of Gordian (*Cod. Just.*, x, xlvi, 1) suggests that this was the regular practice at an earlier date. Magistrates seem as a rule to have been nominated by their predecessors (*Cod. Just.*, XI, xxxiv, 1 and 2).

The papyri relating to the appointment of magistrates seem to me to reveal a stage in the

development of this system. The procedure revealed in these documents is, I need hardly emphasize, radically different from that employed in filling liturgic posts in the public service. With magistrates there is *εἰσδοσις* by a *γραμματεὺς*, no *κλήρωσις* by the *ἐπιστράτηγος*. The terminology implies voluntary candidature. A gymnasiarch at Oxyrhynchus under Antoninus Pius (P. Oxy., 473) received a vote of thanks for his *έκοουσία γυμνασιαρχία*. Such a genuinely voluntary, or perhaps rather spontaneous, candidature was clearly by then a rarity. Candidates are stated to promise to hold office: I may cite P.S.I., 1159, *ἀνθ' ἧς ὑπέσχετο ὁ αὐτὸς Ἡρακλείδης γυμνασιαρχίας*, and P. Ryl., 77, where the magistrates state in their letter that Achilles *ὑπέσχετο . . . ἐξηγητεύσειν*. Other verbs used in this document are *πείθειν*, *προτρέπεσθαι* of the proposer, *πείθεσθαι*, *ἀνα-* or *ἐπιδέχεσθαι* of the candidate. These are untechnical. A technical term obviously misused is *χειροτονεῖν ἑαυτόν* (of the candidate). A technical term of great significance, correctly used, is *προβάλλεσθαι* (of the proposer), *προβάλλεσθαι ἑαυτόν* of the candidate.

The actual procedure we see on one occasion only, the famous Achilles case of P. Ryl., 77. This document will be familiar to all students of the subject, and I need only emphasize the points that are significant for my purpose. The two gymnasiarchs and the exegete, as representing the board of magistrates—this is clear from the letter which they later sign in the name of the *ἄρχοντες*—appear with an advocate and Achilles at the *βῆμα* of the *strategus*. They are apparently under the impression that Achilles is willing to stand as *cosmete*, for the crowd (*οἱ παρεστῶτες ἀπὸ τῆς πόλεως*) have been told to shout: *στεφέσθω Ἀχιλλεὺς κοσμητεῖαν μμοῦ τὸν πατέρα τὸν φιλότιμον γέροντα φῶτα*. I am inclined to agree with those who see in this acclamation a vestigial remnant of popular election. The words used are it is true not quite appropriate to election by acclamation; while the first phrase is what one would expect, since it expresses popular confirmation of a candidate proposed, the second phrase on the other hand seems to urge Achilles to become a candidate. Nevertheless it seems improbable that the shouts of the crowd would be put on record unless they had some constitutional significance, though by this time, it is plain, their original significance had been half forgotten. The first half of the acclamation is the stereotyped constitutional form; the second expresses the present-day reality.

What would have happened next in the normal course—if Achilles had been willing—it is difficult to say. He might have formally announced his candidature—though this seems to have been taken for granted—or he might by silence have expressed his consent. At all events the object of these proceedings before the *strategus* seems to have been to give publicity to the candidature: this is implied in the phrase used in the magistrates' letter to the *strategus*—*ὑπέσχετο ἐπὶ σοῦ ἐξηγητεύσειν*—and by the *strategus*' sole contribution to the proceedings—to order a minute to be taken. In a normal city the necessary publicity would have been secured by holding the proceedings in the city council, as was later done in Egypt also, when the metropoleis acquired councils.

In actual fact Achilles upset the normal procedure by refusing the office of *cosmete* and offering himself for that of *exegete*. A confused situation now arose. The advocate of the magistrates persists in alleging that Achilles had already accepted the office of *cosmete*—this acceptance, perhaps genuine, would being informal have no legal validity—and that if he now offers himself for that of *exegete* he may take both, but he ought not to shirk the greater office for the lesser. These protests do not shake Achilles. The *cosmetes* are then produced and declare that Achilles' candidature for the *έξηγητεία* is, for reasons into which I need not enter, illegal. Every one is clearly anxious to harry Achilles into undertaking the *κοσμητεία*, but since Achilles is stubborn no progress is made by mere protests. And no one is willing to undertake the risk of nominating Achilles formally, since this involves

standing as guarantor. At length Aspidas, who is described as the father of Hermes, former cosmète, pronounces the fatal words *ἰδίῳ κινδύνῳ στέφω Ἀχιλλεῖα τὴν κοσμητείαν*. The advocate seizes on his words: *ἔχομεν δὴ φωνὴν τοῦ Ἀσπιδᾶ ὅτι ἰδίῳ κινδύνῳ αὐτὸν στέφει. καὶ ὀφείλει στεφῆναι, ἤδη γὰρ ἡ ἀρχὴ ἀδιάπτωτός ἐστι τῇ πόλει*. The *strategus* closes the proceedings by ordering a minute to be taken of the statement.

The *strategus* had apparently yet further functions to fulfil. At a later date the magistrates wrote to him, giving a summary of the above proceedings and ending: *ἐπιστέλλεταιί σοι ὁπως ἀκόλουθα τοῖς ἐπὶ σοῦ γενομένοις προνοήσαι πρᾶξαι εἰς τὸ τὴν πόλιν ἀπολαβεῖν τὴν ἀρχήν*. It apparently rested with the *strategus* to enforce the fulfilment of the engagements made in his presence.

I have, I hope, made it probable that the procedure in Achilles' case was, apart from the modifications necessitated by the lack of a city council in the Egyptian metropoleis, the normal procedure for securing candidates for election to magistracies, as followed generally in the cities of the empire. I would now wish to point out the contributions made by the Achilles document to our very imperfect knowledge of the normal procedure. It appears in the first place that it was open to any citizen to make a nomination. Aspidas in this case has no official standing in the matter, not being a magistrate or even ex-magistrate. It has, however, been plausibly argued that he had a good motive, in that his son, for whom he was, according to the rules of Roman law, automatically guarantor, though *κοσμητεύσας* was probably still a member of the *κοινὸν τῶν κοσμητῶν* and therefore still had financial obligations in respect of that magistracy. By adding a member to the *κοινόν* Aspidas would presumably lighten his son's burdens and perhaps hasten his release. It seems to me likely that it was on such motives that the government relied to make the machinery of nomination work. Technically it was open to any citizen to nominate a candidate for a magistracy. Actually the only persons who would face the *κίνδυνος* of a nomination were those who wished to secure their own release from a magistracy. Hence the general practice, later crystallized, it would seem, into a rule, that each magistrate nominated his successor.

A second point of some interest is that at the end of the second century nomination seems only to have been employed as a last resort. If a candidate could be induced to declare himself willing to stand without being formally nominated, so much the better: the *κίνδυνος* was his alone and no nominator was involved. Later it would seem that a candidate was invariably nominated, and even if he assented to his nomination, his nominator was none the less responsible for him.

A third point is suggested by the phrase *τῆς ἀρχῆς τῇ πόλει ἀδιαπτώτου οὔσης ἐξ ὀποτέρου αὐτῶν* used in the magistrates' letter. This may mean no more than that if Achilles' resources were inadequate for discharging his obligations to the city in virtue of his office, they would be supplemented by those of his nominator, Aspidas. But they may allude to the practice of *cessio bonorum*. I hope I may be forgiven if I do not go into that highly controversial subject. It will suffice to say that various documents of the third century (CPR, 20, P. Oxy., 1405, 1642, BGU, 473) allude to the application of this procedure to nominations to magistracies and liturgies. A nominee might apparently, anticipating that his assets would not cover his liabilities, execute a *cessio bonorum* in favour of his nominator, thereby securing himself against the *infamia* and bodily restraint which were the lot of an insolvent debtor. What little we know of this practice is derived almost entirely from the papyri, and it is a good example of the contribution which they make to our knowledge of the constitutional practices of the empire at large. For there is no reason to believe that the practice was confined to Egypt. The reason why the legal sources do not treat it is that it was by Justinian's day

illegal. A constitution of Diocletian (*Cod. Just.*, VII, lxxi, 5) declares: 'Propter honorem municipalem vel munus bonis cedentium invidiosam admitti cessionem minime convenit, sed his obnoxios pro modo substantiae fungi.'

In conclusion I wish to say a few words about the third century. Procedure has now been normalized by the institution of *βουλαί* in the metropoleis. Nominations thus take place no longer before the *strategus*, but, as in the rest of the empire, at a session of the council. The enforcement of candidatures seems likewise to have been transferred from the *strategus* to the *πρύτανις*, acting on behalf of the council: this, I think, appears from CPR, 20, where Aurelius Hermophilus writes to the *πρύτανις* of Hermopolis, protesting against the use of *βία* to enforce the office of *cosmete* on his son after he had effected a *cessio bonorum*.¹ Documents of this period often speak of election by the council—such phrases as *αίρεθεις ὑπὸ τῆς κρατίστης βουλῆς* are common—and as noted above contemporary legal authorities, Ulpian for instance, speak of *creatio* by the *ordo decurionum*. The actual procedure hardly justifies these terms. We see nominations being made in council, and the council is apparently responsible for the enforcement of these nominations, and in the last resort liable for any default by the nominees. The evidence in fact suggests that elections were not transferred from the people to the council by any formal act, but that the election proper (*χειροτονία*) died out, and the preliminary procedure in the council (*προβολή*) alone survived.

On the procedure of nomination the papyri give some interesting information. The *πρύτανις*, as appears explicitly from P. Oxy., 1252 v., and implicitly from the minutes of council meetings (P. Oxy., 1413–15), is responsible for nominations being made but does not, normally at any rate, himself make nominations. The function of the *magistratus* in normal cities was probably analogous. He demands nominations for the regular magistracies from the respective *κοινά*: the rule that a magistrate nominates his successors is thus firmly established. From P. Oxy., 1642, it appears that this method of nomination, technically called *ἀντονομασία*, was legally obligatory for certain magistracies. It was applied by the prefect to the recently revived *ἀγορανομία* (*διὰ τὸ ἐξ ἀντονομασίας συνίστασθαι ταύτην τὴν ἀρχήν, . . . κελεύσαντος τοὺς πληρώσαντας ὀνομάζειν ἀνθ' ἑαυτῶν, . . . ἐν τῇ ὀνομασίᾳ τῇ ὑπ' ἐμοῦ γενομένη . . . εἰς τὴν ἀντ' ἐμοῦ ἀγορανομείαν*). Nominations to extraordinary posts and apparently to membership of the council are made by a *φυλή*. In P. Oxy., 1415, the *πρύτανις* says: *ἀναπλη[ροῦσθε τὸ λειτουργήμα, δότε [. . . ὄν] ομιάσασθε δ[ν] βούλεσθαι*, and the reply comes from *οἱ ἀπὸ τῆς . . .*, and later in the same nomination the councillors say: *οὐκ ἀντιλέξει τῇ φυλῇ ὁ Πτολεμα[ῖος]*. Again in P. Oxy., 1413, when the *πρύτανις* says: *καὶ αἱ ἄλλαι ἀρχαὶ ὀνομασάτωσαν ὀνομάσατε δὲ καὶ βουλευτάς*, the reply (to the latter appeal evidently) comes from *οἱ ἀπὸ τῆς τρίτης φυλῆς*. Here again, as it seems to me, the papyri provide evidence of a widespread constitutional practice of which we know little from other sources. The practice must have been confined to the east, for the *ordo* of a city organized on the Roman model had no divisions corresponding to *φυλαί*. But there is no reason to think that it was confined to Egypt. This is indeed *a priori* highly improbable, for it would imply that Septimius Severus invented it out of his own head: it is far more likely that it was part of the normal organization of a Greek *βουλή*, introduced with the *βουλή* itself into Egypt. And there are faint signs of its existence elsewhere. An inscription of Laodicea of Phrygia (*Ath. Mitt.*, 1891, p. 146, *τῆς βουλῆς τῇ φυλῇ Ἀπολλωνίδι*) shows that the *βουλαί* of Greek cities were still under the empire divided into

¹ Cf. the words of the syndic in P. Oxy., 1413, *ἵνα προτραπῶσιν καὶ ἄρχωσιν οἱ ὀνομαζόμενοι τὸ πρωτεῖαντον τῆς λειτουργησῖα[s] . . .* But the ultimate sanction apparently lay with the provincial governor: *Dig.*, I, iv, 9, 'si quis magistratus in municipio creatus munere iniuncto fungi detrectet, per praesides munus agnoscere cogendus est remediis quibus tutores quoque solent cogi ad munus quod iniunctum est agnoscendum.' Nominations in the last resort were similarly made on the order of the governor. Cf. *Dig.*, XLIX, iv, 1, § 3, 4, and P. Oxy., 1252 v., 1642.

φυλαί. Another inscription from Arabia (*IGR*, III, 1277), recording the repair by a city of an aqueduct, *ἐπισκοπούτων βουλευτῶν φυλῆς Βιταιηνῶν*, shows that this division by *φυλαί* was used in apportioning administrative duties. Finally an inscription from Mylasa (Le Bas-Wadd., 407), *[ἀξι]ωθεὶς ὑπὸ τῆς φυλῆς ὑπέμεινεν γυμνασίαρχος*, shows that at Mylasa the tribes of the city nominated to magistracies.

The object of the system is plain. It was a simple mechanical device for avoiding the iteration of offices by the same persons in successive years; for since the several tribes served for a period, probably a year, in rotation, their members would only be liable to office at intervals of as many years (or other periods) as there were tribes. It is strange that no hint of so useful and to all appearances so common a system should appear in the legal texts; the explanation is perhaps that it was exclusively eastern while the lawyers are more familiar with western forms, perhaps that it was obsolete by the time that Justinian's compilers constructed the Digest and the Code. It is a good example of the contribution which the papyri have to make to our knowledge of imperial administrative law outside Egypt.

NOTES ON UNIVERSITY OF MICHIGAN DEMOTIC PAPYRI FROM PHILADELPHIA¹

BY CHARLES F. NIMS

IN my doctoral dissertation I have translated and discussed a group of demotic papyri from Philadelphia belonging to the University of Michigan.² These papyri, together with a group from Fayyūmic Heliopolis, I hope to publish in the near future. In the meantime I have taken from my discussion several notes of general interest in order to satisfy the requirement that an essential portion of the dissertation be published.

1. The Chronology of the Early Years of Ptolemy Epiphanes

The problem of the chronology of the early years of Epiphanes has recently been discussed by Walbank,³ who shows conclusively that the second year of Epiphanes must have begun October 13 (Thoth 1 of the Egyptian year), 203 B.C., his accession having occurred some time during the previous year. However, since Dinsmoor has shown that the date of the Rosetta Stone, Xandikos 1 (Macedonian), equalling Mecheir 18 (Egyptian), of the ninth year of Epiphanes, is to be equated with March 27 (Julian), 196 B.C.,⁴ the intervening time is one year short of the number of years required for the elapsed period. Walbank proposes that this discrepancy be accounted for by supposing that 'at some time between Epiphanes' second year . . . and his ninth year . . . a year must have been omitted; or alternatively a break occurred part of the way through one Egyptian year, and the period from then to the next Thoth 1 was regarded as a new year, with a fresh set of eponymous priests'.⁵ Knowing of no document dated in year 6, he accepts the first alternative, believing that the sixth year was omitted. However, P. Michigan Inv. No. 4526. A1, 2 is dated in year 6, Choiak,⁶ and in this double document Epiphanes is not yet included in the cult of the gods, nor is the priestess-ship of Arsinoe Philopator mentioned.⁷ Therefore Walbank's theory that year 6 was suppressed, along with its supporting arguments, must be discarded.

¹ I wish to thank the authorities of the University of Michigan for permission to publish these papyri. Professor William F. Edgerton of the Oriental Institute of the University of Chicago has guided me in the reading and interpretation of these documents and has helpfully criticized the manuscript. My colleague, Mr. George R. Hughes, has discussed with me many points of interpretation and translation. Professor Erwin Seidl of Greifswald read a preliminary treatment of the matter discussed in Sect. 5 below, and has given me many helpful suggestions. Mr. Herbert C. Youtie of the University of Michigan and Dr. Raymond A. Bowman of the Oriental Institute have also given me suggestions in regard to this problem. To all of these I wish to acknowledge my indebtedness and deep gratitude.

² C. F. Nims, *University of Michigan Demotic Papyri: Papyri from Philadelphia* (unpublished Ph.D. dissertation, Division of Humanities, Department of Oriental Languages and Literatures, University of Chicago, 1937).

³ F. W. Walbank, *The Accession of Ptolemy Epiphanes*, *JEA* 22, 20 ff.

⁴ W. B. Dinsmoor, *The Archons of Athens in the Hellenistic Age*, 492. The ninth year, then, began October 11, 197 B.C.

⁵ Walbank, *op. cit.*, 31 f.

⁶ The occurrence of year 6 in this document has already been noted; cf. *JEA* 22, 51, n. 2, No. 17.

⁷ Walbank, *op. cit.*, 32, had suggested that, after 'a deterioration of Egyptian morale' because of Egyptian military disasters, 'the popular morale was restored by the deification of Epiphanes, and the institution of a priestess to Arsinoe' at the time when the calendar was changed, and the sixth year omitted.

DATES OCCURRING DURING THE FIRST NINE YEARS OF PTOLEMY EPIPHANES
KNOWN FROM CONTEMPORARY DOCUMENTS

Year of Epiphanes	Months of the Egyptian Year											
	Thoth	Phaophi	Hathur	Choiak	Tubi	Mecheir	Phamenoth	Pharmouthi	Pachon	Pauni	Epeiph	Mesore
1
2	× ¹	× ²	× ³	..
3	× ⁴	× ⁵	..	× ⁶	× ⁷	..
4	× ⁷	× ⁷	× ⁸	..
5	..	× ⁹
6	× ¹⁰
7	× ¹¹	..	× ¹²	× ¹³
8	× ¹⁴
9	× ¹⁵

We must conclude, then, that the second alternative given by Walbank is probably the correct solution of the difficulty. The accompanying table gives the dates noted in contemporary documents so far as known for the first nine years of Epiphanes' reign, and it is seen that there are two possible periods when the break might have taken place, either between Phaophi of year 5 and Choiak of year 6, where there is a period of thirteen months from which we have no dates mentioned in the documents, or between Mecheir of year 7 and Pharmouthi of year 8, when there is a similar period with no dates noted.¹⁶

2. The *sš n snḥ* of Marriage Settlements

P. Michigan Inv. No. 4526. A1, a *sš n snḥ* belonging to the type of marriage settlements usually called 'Alimentary Contracts',¹⁷ has in it two sentences common to this form of document: 'Thou hast caused my heart to be satisfied with the 21 (*deben*) of silver of the

¹ Leiden I. 373c, also Cairo 30753; on the date of the latter, cf. Sethe, *Bürgschaftsurk.*, 104.

² Cairo 30697; the date may be Pauni; cf. Sethe, *op. cit.*, 52.

³ Cairo 30700; Spiegelberg read the month as Phamenoth.

⁴ Cairo 30689+30701+30782.

⁵ BGU VI, 1266.

⁶ Cairo 30659.

⁷ P. Petrie III, 57b.

⁸ Tebtunis III. 1, 820.

⁹ N.Y. Hist. Soc. 373b, N. J. Reich, *New Documents from the Serapeum, Mizraim* 1, Pl. vii.

¹⁰ P. Mich. Inv. No. 4526. A1, 2.

¹¹ Louvre 2435, E. Revillout, *Chrestomathie démotique*, 389.

¹² Dublin, Trin. Coll. pap. Hincks, 2A, B, Thompson, in *Griffith Studies*, 20, 27.

¹³ B.M. 10575/2, 3, Thompson, *A Family Archive from Siut*, Pls. xvii-xxii; also B.M. 10591, verso, col. v/5, *ibid.*, Pl. xiv.

¹⁴ Louvre 2408, Revillout, *op. cit.*, 336.

¹⁵ Rosetta Stone.

¹⁶ It should be emphasized that the appearance of documents having dates in both these periods so as to make the elapsed time in each less than twelve months would, of course, necessitate a new theory for the solution of this chronological problem.

¹⁷ For a catalogue of these marriage settlements cf. W. Spiegelberg, *Demotische Papyri (Veröffentlichungen aus den badischen Papyrus-Sammlungen, Heft 1)* (hereafter referred to as Spiegelberg, *VBP*, 1), 38 to which add B.M. 10591, cols. vi/21-vii/5, Thompson, *op. cit.*, Pls. vi, vii, pp. 8, 25 f.; the Greek abstracts published by A. E. R. Boak in *JEA* 12, 100 ff., and republished by the same author, *Papyri from Tebtunis*, I, 29 ff., 45 f., 52 f., 58 ff., 67 f., and P. Mich. 624, referred to by Boak, *JEA* 12, 107. A translation of this last document by W. F. Edgerton is now in the press.

treasury of Ptaḥ, refined, . . . as thy *sṅḥ*', and, 'I shall not be able to say to thee, "Receive thy *sṅḥ* aforesaid from my hand", (but) at the time when thou desirest it from me, I will give it to thee.' I do not believe that the proper interpretation has been given to two matters involved in these sentences, namely, the meaning of *sṅḥ* and the nature of the sum involved (21 *deben* of silver in the Michigan papyrus). These two problems must be considered together.

Griffith, commenting on the word *sṅḥ* as it was used in P. dém. Bibl. Nat. Paris 219, speaks of the *sṅḥ* as 'an annuity',¹ and Spiegelberg, in his translation of this document, gives the word the meaning of 'Alimentation (Unterhalt)'.² Further, the sentence, 'I shall not be able to say to thee, etc.', is paraphrased by Möller, 'Du hast die Zeit zu bestimmen, wo du ihn von mir empfangen willst',³ and it would seem, if I understand him correctly, that he takes this to refer to 'Lebensunterhalt' (ⲉⲕⲏⲓ ⲥⲃⲥ). Thus it would seem that there exists a confusion between *sṅḥ* and the yearly stipend for food and clothing. However, in this sentence *sṅḥ* does not refer to this yearly payment; it is clearly stated in every *sš n sṅḥ* that the *sṅḥ* is the 'X *deben* of silver of the treasury of Ptaḥ, refined'.

Until recently it seems to have been universal to translate *sṅḥ* as 'alimentation';⁴ however, Thompson has lately made the comment, 'To avoid giving a too precise legal meaning, I have adopted the words "endowed" and "endowment" for *sṅḥ*'.⁵ It is to be admitted that the verb *sṅḥ* means 'to nurture', and that etymologically the noun should mean 'the nurture', *i.e.* 'alimentation'. But I believe that a careful consideration of the evidence, presented below, shows that in its usage the noun means rather 'that which produces nurture', *i.e.* 'revenue-producing property', as opposed to 'revenue', and that Thompson's translation of the word gives the true legal meaning.

Junker, in the course of his discussion of this type of marriage settlement, indicates his belief that the money of endowment is a fictitious payment or deposit whose object was to fix the amount which had to be paid by the husband to the wife in case of divorce,⁶ and he is followed in this conclusion by Boak.⁷ Spiegelberg, however, even after the publication of Junker's conclusions that the marriage settlements represented by the *sš n sṅḥ* were not materially different from other marriage settlements, still believed that this type of document represented a 'loose marriage' or 'trial marriage', and took the position that the money of endowment was an actual amount from which the man paid the woman her yearly stipend, and, in support of his view, stated that the capital amount would be exhausted in about ten years.⁸

P. Michigan Inv. No. 4244. 4a⁹ throws further light on this problem. In lines 6 ff. the husband says to the wife, 'Thou hast given to me [money and objects of which the value is] 4 talents 50 (*deben*) of silver, the [remainder] (*sp*) of thy dowry in the name of the

¹ Griffith, *Ryl. Pap.*, 99, n. 3; 113.

² Spiegelberg, *VBP*, I, 41 f.

³ Möller, *Zwei äg. Eheverträge aus vorsaitischer Zeit*, 27.

⁴ It should be pointed out that Griffith, *op. cit.*, 115, n. 6, after translating *sṅḥ* as 'revenue (?)' in the text, gives as suggested alternatives 'investment', 'money on loan', 'annuity', and 'pension', but, as the comment noted above shows, he did not finally accept the meaning 'investment', which is, I believe, the most nearly correct of his various proposals.

⁵ Thompson, *op. cit.*, 12, n. 8.

⁶ H. Junker, *Papyrus Londorfer I*, 50; *cf.* also Edgerton, *Notes on Egyptian Marriage chiefly in the Ptolemaic Period*, 9, n. 2.

⁷ Boak, *JEA* 12, 108.

⁸ Spiegelberg, *VBP*, I, 36 f. Edgerton, *op. cit.*, 8 f., takes the same view of Spiegelberg's theory as that more fully developed below.

⁹ This document and others bearing the number 4244 come from Fayyūmic Heliopolis.

document of endowment of 21 (*deben*) of silver.¹ The implication of this document is clear. The document of endowment is made by the husband in consideration of a capital amount brought by the wife, and the money of endowment is neither an 'actual' nor a 'fictitious' amount, but rather a 'nominal' one.

Further information on the responsibility of the husband is to be had from a document which appears to be a form of marriage settlement, Cairo 50129.² The principal provisions of this contract can be summarized as follows: The man acknowledges the receipt of 500 *deben* of silver, the dowry (?),³ from the woman, and promises to provide her with 24 measures of grain and 200 *deben* of silver as her yearly stipend. The payment is to continue until such time as the woman desires the return of the amount of the dowry, at which time it must be repaid within thirty days. If the money is not repaid, the stipend is to be continued until such time as the woman receives the 500 *deben* of silver. Of a similar nature is the marriage settlement B.M. 10593,⁴ though the provision for the return of the dowry is dependent on divorce. In line 4 we read, 'If I divorce thee, . . . I will give them [*i.e.* 110 *deben* of silver, the value of the dowry] to thee at the time when thou wishest them from me, on a day within thirty days of wishing the 110 (*deben*) of silver aforesaid from me.' Such a statement would seem to imply that even after the divorce the dowry cannot be returned until the woman requests it. Of the same nature is the marriage settlement Leiden I. 373a.⁵ Though none of these documents mentions any connexion between the dowry and the money of endowment, both P. Michigan Inv. No. 4244. 4a and Karāra II show that the document of endowment was given in consideration of the dowry brought by the wife.⁶

¹ It would seem that Karāra II/3-4 (*cf.* Spiegelberg, *VBP*, I, Pl. ii and pp. 25 ff.) has a similar statement. Spiegelberg had read, *dj-t mtj hstj-i n pry-k(?) ¼ (?) r (?) grk-t (?) ʿrm-t (?) n rn p: sh snh n hd LI*. He believed that the $\frac{1}{4}$ referred to a quarter of the 200 *deben* of silver mentioned in l. 5, of which 51 *deben* is approximately the correct amount. But the reading $\frac{1}{4}$ cannot be correct; the stroke which Spiegelberg took to be the tail of $\frac{1}{4}$ does not belong to the sign at the end of l. 3, but is actually part of the word *wth* in the line below; *cf.* the writing of *wth* in l. 14. Because of the evident scribal confusion between the suffix pronouns of the 2 s. m. and f. in l. 5, where *sk* is written instead of *st*, it might be possible to read *pry-k* and take the following sign to be $\frac{1}{2}$. But since, in l. 5, we have the statement, 'You have given to me 200 (*deben*) of silver', showing that the husband received the whole amount, and especially since ll. 10-11, reading, 'At the time when you shall wish them from me, I will give them to you', seem to indicate that the entire 200 *deben* of silver is to be returned, I do not feel that the reading *pry-k* $\frac{1}{2}$ can be at all certain. From the facsimile it is tempting to see here, following the reading of P. Mich. Inv. No. 4244. 4a/9, the words *p: sp*, though there is some paleographic difficulty in the stroke which appears to follow the *p:* both in the facsimile and in Spiegelberg's hand-copy of this group (*ibid.*, 33). However, it is not possible to maintain Spiegelberg's position that there was written here *pry-k* $\frac{1}{4}$, representing the 51 *deben* of silver as a quarter of the value of the dowry.

² W. Spiegelberg, *Die demotischen Denkmäler*, III: *Demotische Inschriften und Papyri* (CCG, XCII), Pl. lvi and pp. 93 f. The summary is made from my own translation, which differs in several particulars from that given by Spiegelberg.

³ The reading of the signs here is uncertain, and is further obscured by the cancelling lines. I have read tentatively *pryt hd ʿnk-t hmt*, 'thy silver of wife's 'property''. Hughes suggests *pryt hd n ʿr ny hmt*, 'thy silver of becoming my wife'. The receipt of the dowry in this document was first suggested by E. Seidl, *Aeg.* 13, 81, n. 1.

⁴ Thompson, *op. cit.*, Pl. xxiv, pp. 68 ff.

⁵ Translated by Spiegelberg, *Rec. Trav.* 28, 194 f.; *cf.* also Möller, *op. cit.*, 22, Schema VI.

⁶ It is interesting to note that the parties to B.M. 10593 drew up, six months later, a document of 21 *deben* of silver, B.M. 10594; *cf.* Thompson, *op. cit.*, Pls. xxvi, xxvii, pp. 70 ff. This is not called a 'document of endowment', but the 21 *deben* of silver and the provisions of the contract show that it could be considered as such. However, the main emphasis seems to be on the provisions for the return of the said sum. But the yearly stipend mentioned in the latter papyrus is not the same as that enumerated in B.M. 10593, and the relationship between these two documents is difficult to determine.

The endowment sum is, then, a nominal amount representing money or value received by the husband from the wife. He does not pay the yearly stipend for sustenance from it, and so use it up, as Spiegelberg suggested, but it is treated as principal, in relation to which the payments to the woman for sustenance must be treated as interest, since even in the case of divorce it would seem that these payments must be continued until such time as the woman desires the repayment of the dowry or principal sum. Nor can the husband force his wife to accept the return of the dowry, but he can give it to her only when she requests it, as is shown by the sentence, 'I shall not be able to say to thee, "Receive thy endowment from my hand", (but) at the time when thou desirest it from me, I will give it to thee'.¹

3. The Independent Use of the Conjunctive *mtwz*

P. Michigan Inv. No. 4526. A1, following the names of the contracting parties, reads, *d̄i-t̄ m[tr h̄-t̄z̄y] n h̄d 21 . . . n p̄r̄y-t̄ s̄n̄h̄ m̄twz n̄ h̄rd-t̄w r m̄s-t̄t̄ n̄z̄y h̄n̄c̄ n̄z̄ h̄rd [t̄-w n̄ty] [i-ir̄-t̄] [r] m̄s-t̄z̄w n̄z̄y n̄ty n̄b n̄ty m̄twz̄y h̄n̄c̄ n̄z̄ n̄ty īwz̄y d̄i-t̄ h̄p̄r̄z̄w p̄r̄y-t̄ š̄r̄y ʿ p̄r̄y š̄r̄y ʿ p̄r̄y h̄n̄ n̄z̄ h̄rd-t̄-w r m̄s-t̄t̄ h̄n̄c̄ n̄z̄ h̄rd-t̄-w n̄ty [i-]ir̄-t̄ r m̄s-t̄z̄w n̄z̄y m̄twz̄y d̄i-t̄ n̄z̄t̄ [š̄s̄] 72 n̄ [sw] . . . n p̄r̄y-t̄ [ʿk̄] h̄bs h̄r r̄m̄p̄-t̄, 'Thou hast caused [my heart to be satisfied] with 21 (*deben*) of silver . . . as thy endowment. To the children whom thou hast borne to me together with the child[ren whom] thou wilt bear to me belong everything which is mine together with that [which I shall acquire. Thy eldest son is my eldest son among the children whom thou hast borne together with the children whom thou wilt bear to me. I am to give to thee 72 (measures) of [wheat] in [grain] . . . as thy food and clothing yearly.' Here, in the last sentence quoted, the conjunctive *mtwz* does not continue the mood and tense of any preceding verb, but is used independently. In this independent use *mtwz* is to be translated as an independent future, implying obligation; thus it has here the sense, 'I am (obliged) to give to you . . .'. Spiegelberg has pointed out a similar usage following a conditional clause,² but there are many examples where, as in this document, there is no conditional clause actually present or implied. Earlier occurrences of this usage with the same wording as 4526. A1 are the marriage settlements Karāra I/1³ and Rylands 10/2.⁴ Ostrakon Strassburg d. 1845/7 has *mtwz̄t h̄p̄r n̄ p̄r̄y ʿw̄y*, 'You are to be in my house'.⁵ Thompson has published a demotic ostrakon of magical content which, in line 4, reads, *mtwz̄w th̄b̄z̄w h̄r mw*, 'They are to be sprinkled with water' (so translated by Thompson).⁶ Similarly, in the Magical Papyrus, *mtwz̄k d̄i-t̄*, 'You are to put (it in something)', follows the name of the ingredient.⁷ In leases the independent use of *mtwz* often occurs following the neighbours of the property, where it begins a new thought; cf., for instance, Berlin 3102/13, *mtwz̄y sk̄z*, 'I am to plough',⁸*

¹ I believe that the translation of *s̄n̄h̄* by 'endowment' is established for its usage in 'documents of *s̄n̄h̄*' by the foregoing discussion. Moreover, such a meaning is entirely in keeping with the use of *s̄n̄h̄* in other cases, such as, for instance, Brussels 3/2, Spiegelberg, *Die demotischen Papyrus d. Musées Royaux du Cinquantenaire*, Pls. iv, v, translated also by Sethe, *Bürgschaftsurk.*, 720 ff.

² Spiegelberg, *Dem. Gr.*, § 152.

³ Spiegelberg, *VBP*, I, 21. This document is dated about 342-332 B.C.; cf. *ibid.*, 28.

⁴ Griffith, *op. cit.*, Pl. xlviii. This document is dated 315 B.C. I am indebted to Edgerton for this and the two following references.

⁵ Edgerton, *op. cit.*, 10, 13.

⁶ Thompson, *PSBA* 35, 95 ff.

⁷ Griffith and Thompson, *The Demotic Magical Papyrus of London and Leiden*, Pls. xi/21-22, xii/28. Edgerton has called my attention to a similar usage in the Dendera texts pointed out by Junker, *Sprachliche Verschiedenheiten in den Inschriften von Dendera*, 9, § 17. 2.

⁸ Spiegelberg, *Demotische Papyrus . . . Berlin*, Pl. xxx. I am indebted to Hughes for calling my attention to this usage in leases.

similarly, Strassburg 9/11, *mtwzy d̄i:t mw r-r̄z̄f*, 'I am to put water on it'.¹ A closely parallel use is found in P. Michigan Inv. No. 4244. 4a/17-19, 'Thou hast claim on me again (in regard to) the law of the agreement (ϣ̄) which I made to thee on the document of endowment . . . as well as the law of the agreement aforesaid, making two agreements, and I will do (*mtwzy*) for thee their law'. Many parallels to this last might be quoted.²

4. The Use of *m-s̄* with the Meaning 'pertaining to'

In P. Michigan Inv. No. 4526. C2, the 'Document of Cession'³ of the sale of half of a house, the property is described as 'thy half part of the house . . . together with the half part of its courtyard which is south of it [*nty*] [*m-s̄z̄f*]'. The restoration is based on P. Michigan Inv. No. 4244. 1/5, 'thy house . . . together with thy courtyard *m-s̄z̄f* south of it', and P. Michigan Inv. No. 4244. 6a/2, 'the birth (hy(·t) of the ibises together with the southern 'house' of the ibis and the falcon *nty m-s̄z̄s*'. Literally, *m-s̄* means 'behind', but I believe that in the usages above quoted *m-s̄* is to be taken in the sense of 'pertaining to',⁴ and that *nty m-s̄z̄f* (or *nty m-s̄z̄s*) is to be translated 'which pertains to it'. The use of *m-s̄* in this sense does not seem to have been recognized previously; however, Hughes has called my attention to a similar usage in Rylands 17.⁵ In the body of the document, line 3, the property is described as 'the house . . . comprising a chamber, a vestibule, a staircase below upward', but in the agreement made by the wife of the seller, the property is described as *pyz̄f ʿwy ʿirm n̄s nty m-s̄z̄f nty hry*. Griffith had taken the latter phrase to mean 'they that have claim on him', 'those things that (are written) after it',⁶ or 'those things which follow it',⁷ but is it not rather 'his house and those things which pertain to it aforesaid'? A similar usage is found in P. Michigan Inv. No. 4526. B2/x-3, *p̄s s̄s̄ . . . m-s̄ t̄s dny-t p̄s̄ p̄s̄ ʿwy*, 'the document . . . pertaining to the half part of the house', paralleled by a passage in Louvre 2434-2437, *s̄s̄ n̄ wy m-s̄ p̄y ʿwy*, 'document of cession pertaining to my house'.⁸

5. The Title *ʿrb̄t̄* and 'Letters of Agreement'

Spiegelberg has published a fragmentary papyrus, Loeb 62, in which one of the persons named therein bears the title *ʿrb̄t̄*.⁹ Since at that time no parallel documents were known, it was not possible to ascertain the import of this title nor to have any clear idea as to the nature of the document. However, in the group of Michigan papyri from Philadelphia there are two documents, both fragmentary, which contain the title *ʿrb̄t̄*, and one of these is complete enough to enable us now to determine the nature of the transaction with which the man bearing this title is associated.

P. Michigan Inv. No. 4200, written in the twentieth year of Epiphanes, is badly pre-

¹ Spiegelberg, *Die demotischen Papyrus d. Strassburger Bibliothek*, Pl. vii.

² Edgerton has called my attention to a similar usage in a hieratic text from the Twenty-first Dynasty, Spiegelberg, *ZÄS* 53, 12, l. 9.

³ Seidl questions my translation of *s̄s̄ n̄ wy* as 'cession', and points out to me that it should be translated 'Abstandsurkunde' rather than 'Zession'; cf. the remarks by Partsch in Spiegelberg, *Die demotischen Papyri Hauswaldt*, 12* ff. However, since the translation 'cession' is customary in English, I have continued to use this term, but I do not seek by such a translation to imply any particular juristic interpretation.

⁴ *ⲛⲓⲥⲁ* does not appear to have this meaning in Coptic; cf. Crum, *Copt. Dict.*, 314.

⁵ Griffith, *op. cit.*, Pl. lxxv, pp. 273 ff., 142 ff.

⁶ *Ibid.*, 274, n. 6.

⁷ *Ibid.*, 144, n. 9.

⁸ Revillout, *Chrestomathie démotique*, 212.

⁹ Spiegelberg, *Die demotischen Papyri Loeb*, Pl. xxxiv, and cols. 94 ff. Spiegelberg had read the title *ʿrb̄*, without the *t̄*, but this can be seen on the facsimile, l. 7, and is confirmed by the Michigan documents.

served, and only fragments of the upper portion of this document remain. Following the protocol, the document reads:

The agreement to which [. . . Pa]neith the younger, son of 'Orses¹, [his mother (being) . . . , and] the woman *Tikas, daughter of Teos, her mother (being) *[Ta]nas, came . . . in the presence of [the *ꜣbꜥ*] Pneferos, son of Petesouchos, (in) year 20, Choiak.

['They spoke¹] in the presence of the *ꜣbꜥ* Pnefer[os] aforesaid, saying:

We have given¹ to thee the letter of agreement (*tr šꜥt hn*) ['whose conditions¹] 'are written below¹ (concerning) the house which we bought [from . . .] Patous [the younger, son of] 'Patous¹, [. . .] . . of which Paneith the younger, son of ['Orses¹], owns [. . .] . . half 'on its¹ western 'side¹, and [*Tikas, daughter of Teos], owns [. . . half on its eastern side].

The ownership of the property is confirmed by P. Michigan Inv. No. 4526. C1, 2, recording the sale of the eastern half of the house to *Tikas, and noting the previous (?) sale of the western half to Paneith.

In P. Michigan Inv. No. 4526. B1 the lower portion of another 'Letter of Agreement' is preserved, and from what is extant, together with some help from 4200 and Loeb 62, the missing part can be restored with a considerable degree of certainty. With the restorations it reads:

[The agreement to which *Tikas, daughter of Teos, her mother (being) *Tanas, and Ḥor, (son of) Patous, his mother (being) '*Nebwotis¹, came in the presence of the *ꜣbꜥ* Peteüris, (son of) . . . , in year . . . , month . . .

'They spoke¹ in the presence of the *ꜣbꜥ* Peteüris aforesaid, saying:

We have given to thee the letter of agreement . . . (in regard to) 150 (*deben*) 4 *kite* of silver.

The woman *Tikas, daughter of Teos, aforesaid, says it (in the presence of) Peteüris, the *ꜣbꜥ* aforesaid:

Ḥor, (son of) Patous, aforesaid, has given to me 150 (*deben*) 4 *kite* of silver . . . , principal and interest, in year . . . , month . . . ; I have received them from his hand; my heart is satisfied therewith; they are complete without any remainder.

I have given to him the document of specie payment and the document of cession pertaining to my half-part of the house

If I have given the 150 (*deben*) 4 *kite* of silver (at the rate of) 24 (*kite*) of copper to 2 *kite* (of silver) aforesaid to Ḥor, (son of) Patous, aforesaid, by year 22, 'Mecheir¹, the last day, the appointed time, he shall give to me the document of specie payment and the document of cession, making two documents which are in his possession, and he shall be far (from) the *ꜣbꜥ* (in regard to) this letter of agreement which is in his [possession, making] 'three¹ documents. He shall [give them to me without citing any title or] any matter in the world.

If I have not given the 150 (*deben*) 4 *kite* of silver (at the rate of) 24 (*kite*) of copper to 2 *kite* (of silver) aforesaid to Ḥor, (son of) Patous, by year 22, 'Mecheir¹, the last day, the appointed time

¹ *Dim.* Seidl has raised the question, which also occurred to me, as to whether the use of the perfect here refers to the present document or to a *šꜥt hn* given at some previous time, to which this document refers. I am of the opinion, however, that in spite of the use of the perfect tense of the verb, the letter of agreement which has been given to the *ꜣbꜥ* is the document 4200 itself. Note that Loeb 62/8 speaks of [*nš hn(-w)*] *nty hry* (the restoration is certain) being given (the verb must be restored) *n dr-ꜥꜥ*, i.e. into the hand of the *ꜣbꜥ*, though the actual agreement follows, having been mentioned previously only in the introductory clause, 'The agreement to which A and B came'. So, too, in cessions, such as, for instance, B.M. 10616; B. 1/6-7, cf. Glanville, *Griffith Studies*, Pl. xvii, the sentence 'I will make for thee the document aforesaid' is followed immediately by 'Thou hast claim on me in regard to the law of the document of specie payment which I have made for thee [on a certain date], making two documents which I have made for thee'. It does not seem improbable that through a juristic fiction the sentence, 'We have given to thee the letter of agreement', may refer to the document in which this sentence is contained, even though the writing of the document is not yet completed, and has not yet been handed over to the *ꜣbꜥ*.

aforesaid, I will be far from him (in regard to) the document of specie payment and the document of cession, making two documents which are in his possession, and I will be far (from) the *ʿrbṯ* (in regard to) this letter of agreement which is in his possession, making three documents. They shall be given to him¹ without citing any title or any matter in the world. I shall be far from him² (in regard to) my half part, the measurements of which and the neighbours of which are written above. He shall pay its twentieth to the bank of Pharaoh (on) a day within ten days after the appointed time aforesaid.

The farmer Petearmotis, (son of) Patous, the husband of *Tikas, daughter of Teos, aforesaid, stands and says:

Write and do everything aforesaid; my heart is satisfied therewith.

The farmer Ḥor, (son of) Patous, aforesaid, says it (in the presence of) Peteüris, the *ʿrbṯ* aforesaid:

If the woman *Tikas, daughter of Teos, aforesaid, has given to me the 150 (*deben*) 4 *kite* of silver aforesaid at the appointed time aforesaid, I will give to her the document of specie payment and the document of cession which are in my possession. I will be far (from) the *ʿrbṯ* (in regard to) [this letter] of agreement, making three documents, and I will give them to her.

If I have not given to her the documents aforesaid at the appointed time aforesaid of giving to me the money aforesaid which she shall do, I will give 300 (*deben*) of silver to the burnt offerings and the [libations] of Pharaoh Ptolemy, (son of) Ptolemy, in the month named. She shall have claim on me to give to her the documents aforesaid still, without citing any title or any matter in the world.

In Loeb 62, Herieus the younger, son of Kasanoupis and Kollauthis, and Pneferos, son of Petesouchos and Teos, come to an agreement in the presence of the *ʿrbṯ* 'Herieus', son of Petearmotis. In this case Pneferos has given to Herieus the younger 70 *deben* of silver. As security, Herieus the younger has given to Pneferos a 'document of 21 (*deben*) of silver of the treasury of Ptah, refined', which Herieus the younger made in the name of Pneferos and that of Taonnophris, his daughter, on the day on which Pneferos gave the 70 *deben* of silver to Herieus the younger. If Herieus the younger repays the 70 *deben* of silver by the time appointed, he is to be given back the document of 21 *deben* of silver; if he does not repay the money by the time appointed, it would seem that the document of 21 *deben* of silver is to continue in force.³ The other provisions, including those concerning the *ʿrbṯ*, are the same as those in 4526. B1.⁴

Thus we have three documents, called 'Letters of Agreement' in the case of the Michigan papyri, and simply an 'Agreement' in the case of Loeb 62, all containing a reference to *ʿrbṯ*, written within a period of thirteen years,⁵ and possibly coming from the same com-

¹ *I.e.* to Ḥor.

² Or possibly, 'from them'.

³ I am of the opinion that this document of 21 *deben* of silver was a document of endowment; note B.M. 10594, Thompson, *A Family Archive from Siut*, Pls. xxvi, xxvii, where a document of 21 *deben* of silver, a marriage settlement, is not called a document of endowment, but has provisions for a yearly stipend; *cf.* p. 76, n. 6, above. *Cf.* also P. dém. Bibl. Nat. Paris 219, transliterated and translated by Spiegelberg, *VBP*, I, 41 f., where the document of endowment is made out to the father for his daughter. I do not believe that it is necessary to consider the document of 21 *deben* of silver mentioned in Loeb 62 as a marriage settlement, and the fact that it might be cancelled by the repayment of the money would seem to weigh against this. However, if it is a document of endowment, this would explain its value as a security.

⁴ This summary of Loeb 62 is based on a restoration I have made of that document. I hope to be able to publish a facsimile of this restoration, together with a discussion of the document, in the near future.

⁵ 4200 is dated in the twentieth year of Epiphanes. 4526. B1 has the twenty-second year of the same reign as the date on which the payment of the money falls due, and if, as I believe possible, it concerns the property which is mentioned in 4200, and for which we have the record of the sale, P. Mich. Inv. No. 4526. C1, 2, also dated in the twentieth year, it must have been executed at or subsequent to the same time. In Loeb 62 the repayment of the money is due in the eighth year of Philometor (*cf.* l. 13), and there is good reason to suppose that the latter document was written in the seventh year.

munity.¹ Each document records the appearance of two parties before the ḳrbꜛ, in whose presence they have set forth the agreement to which they have come. The nature of the transaction and the responsibility of each party in connexion therewith are recorded in this letter of agreement, which is then delivered to the ḳrbꜛ, and which he holds until the conditions therein set forth are fulfilled, at which time he turns over the document to whichever party is entitled to it. In 4200 the conditions of the agreement are lost; both 4256. B1 and Loeb 62 are concerned with a loan of money and the security thereof.

Briefly, in 4526. B1 the situation is this. The woman *Tikas has borrowed from Ḳor a sum of money which, with its interest,² amounts to 150 *deben* 4 *kite* of silver. In return she has given to him as surety documents of specie payment and cession, the title to her half-part (of a house). Such a transaction was, for all purposes, a mortgage, though it is different from those published by Spiegelberg, which describe the amount loaned and the property involved,³ and from Hauswaldt 18, republished with commentary by Sethe, in which the first document is a tentative document of specie payment, describing the property and giving the amount loaned, and the second a cession, evidently made after the loan had fallen due and was not paid, *i.e.* a foreclosure.⁴ Since Ḳor held the documents which gave him title to the property, it was necessary to make a record of this transaction to ensure that the conditions of this contract would be fulfilled. For this purpose *Tikas and Ḳor came before a third and disinterested party, the ḳrbꜛ Peteüris,⁵ and set forth the conditions and obligations of the contract in the letter of agreement which remained in the possession of the ḳrbꜛ until the contract was fulfilled either by the repayment of the loan or the forfeiture of the security. In Loeb 62 the conditions, allowing for the difference in the nature of the security, are the same.

Aside from holding this letter of agreement, it would seem that the ḳrbꜛ had no other responsibilities. His duties come to an end on the day the repayment of the money is due, and the letter of agreement is delivered to the person legally entitled to it; if the loan has been repaid, to *Tikas in 4526. B1, and to Herieus the younger in Loeb 62; if the loan has not been repaid, then to Ḳor in 4526. B1, and to Pnferos in Loeb 62.⁶ And since, if the loan is repaid, *Tikas and Herieus the younger respectively are then in possession of the letters of agreement, it is they, and not the ḳrbꜛ, who must enforce the penalty in case the documents given as security are not returned, as Seidl has pointed out to me.

¹ Spiegelberg believed that, because the parties concerned were 'servants of Hathor mistress-of-Aphroditopolis', Loeb 62 came from Aphroditopolis. However, we know from other documents in the Michigan group from Philadelphia, all of which belong to the same family, that the husband and the father-in-law of *Tikas were also 'servants of Hathor mistress-of-Aphroditopolis', and it seems probable that Paneith and Peteüris, the ḳrbꜛ, also bore this designation. The two other documents known to me which have in them this designation also come from Philadelphia; *cf.* P. demot. Zenon 6/2, 5, Spiegelberg, *Die demotischen Urkunden des Zenon-Archivs (Demotische Studien, VIII)*, p. 14, Pl. v; B.M. 10616. A4/1, Glanville, *op. cit.*, Pl. xvi (Glanville, *op. cit.*, 156, had read Ḳrꜛ (?) for what is certainly *tp-ih-t*). Since Philadelphia is the known provenance of the other papyri which contain 'servants of Hathor mistress-of-Aphroditopolis', it would seem at least possible that Loeb 62 also came thence.

² The words *ḳsdꜛ ms* do not appear in the extant portion of the document, but it is probable, as in Loeb 62, that the amount named represented both principal and interest.

³ Spiegelberg, *Rec. Trav.* 31, 91 ff.

⁴ Sethe, *Bürgschaftsurk.*, No. 12, pp. 246 ff.

⁵ We do not possess the beginning of 4526. B1, but it seems probable, from its nature, that the opening clauses were parallel to 4200 and Loeb 62.

⁶ The documents make no provision for the presentation to the ḳrbꜛ of evidence as to whether the loan has or has not been repaid. The question still remains as to what assurance the ḳrbꜛ might have had in regard to which of the two parties was legally entitled to the agreement after the date on which the loan fell due.

It is probable, therefore, that $\epsilon\rho\beta\zeta$ is the legal title for a disinterested party who has in his care the record of a transaction in order that there may be available such a record in case the contract is not fulfilled. In the case of non-fulfilment or dispute, this record could be used as a basis for suit, though this is not stated. Further, I believe that the office of $\epsilon\rho\beta\zeta$ was not regularly established, but that, in all probability, a private individual functioned as such only for the period of his responsibility. In 4200 the $\epsilon\rho\beta\zeta$ is one Pneferos, son of Petesouchos; in Loeb 62 one of the contracting parties is Pneferos, son of Petesouchos, who is there a farmer. If these two documents do come from the same community in Philadelphia, it is possible that we have the same person mentioned in each document, and that the man acting as $\epsilon\rho\beta\zeta$ in 4200 was a farmer by occupation.

We have, in these papyri, a new type of legal document, with no known parallels among contemporary papyri,¹ and a new juristic functionary. Having established the function of the $\epsilon\rho\beta\zeta$ in the documents P. Michigan Inv. No. 4526. B1 and Loeb 62, we need some word by which this title can be translated. Seidl has suggested that the duties of the $\epsilon\rho\beta\zeta$ would indicate that he served as a 'trustee', and I provisionally accept this translation.²

One further word must be said. The foregoing discussion is based on 4526. B1 and Loeb 62. Since the terms of the agreement in 4200 are lost, we can only presume that the duties of the $\epsilon\rho\beta\zeta$ in this case were similar. But since both 4526. B1 and Loeb 62 are concerned with the loan of money and the security thereof, while 4200 seems, at least, to deal with no such matters, we cannot be certain of the duties of the $\epsilon\rho\beta\zeta$ in connexion with that document. Perhaps 4200 was an agreement dealing with the property rights of each person in regard to the house of which each owned half. If this be true, the responsibility of the $\epsilon\rho\beta\zeta$ in holding the document would extend over a considerable period of time.

¹ There is some degree of similarity between the duties of the $\epsilon\rho\beta\zeta$ and the well-known *syngraphophylax* of the Greek papyri. But the *syngraphophylax* is merely one of the witnesses who holds the document, while the $\epsilon\rho\beta\zeta$ has a definite juristic function in connexion with the document itself, in which he and his duties are mentioned.

Seidl calls my attention to a *συγγραφὴ ἀνήσ ἐν πίστει* (cf. M., *Chr.*, No. 233, pp. 257 f.), and he points out that the giving of the two title documents in 4526. B1 is also an *ἀνή ἐν πίστει*, but that, in 4526. B1 we have the $\epsilon\rho\beta\zeta$, whose duty it is to watch over the observation of this *πίστις*.

² The duties and the position of the $\epsilon\rho\beta\zeta$ having been determined, it is doubtful whether this word can be connected etymologically with the Coptic $\alpha\rho\mu\acute{\eta}$ 'pledge', 'deposit of money' from $\epsilon\rho\beta$ 'take in pledge, give in pledge'.

THE MANSION OF LIFE AND THE MASTER OF THE KING'S LARGESS

By ALAN H. GARDINER

With Plates v, vi

THE present article on the $\overline{\text{𓂏}}\overline{\text{𓂏}}$, var. $\overline{\text{𓂏}}\overline{\text{𓂏}}$, *hwt-ꜥnh* is intended as the prelude to a longer study on the $\overline{\text{𓂏}}\overline{\text{𓂏}}$ *pr-ꜥnh* to appear in *JEÄ* 24, part 2. The $\overline{\text{𓂏}}\overline{\text{𓂏}}$ or 'House of Life' is well known as a place connected with the activities of the most learned scribes of Egypt, and the question arises whether the $\overline{\text{𓂏}}\overline{\text{𓂏}}$, which our materials present as on the whole a much older designation, is identical with the $\overline{\text{𓂏}}\overline{\text{𓂏}}$ or to be distinguished from it. In order to differentiate between the two I render $\overline{\text{𓂏}}\overline{\text{𓂏}}$ as 'Mansion of Life'. It must be acknowledged at the outset that one piece of evidence speaks in favour of identity. This is the Famine stela of Sehêl (No. 31 of my article on *pr-ꜥnh*) where King Djoser appeals to the learned Imhôtep for information about the sources of the Nile, and the famous sage asks permission to be allowed to consult the ancient books in the 'Mansion of Life' ($\overline{\text{𓂏}}\overline{\text{𓂏}}\overline{\text{𓂏}}\overline{\text{𓂏}}\overline{\text{𓂏}}\overline{\text{𓂏}}$). However, the other evidence on $\overline{\text{𓂏}}\overline{\text{𓂏}}$ which I have collected is so inimical to the notion of identity that some means must necessarily be found of explaining away this isolated instance. Was it a simple error on the part of the Ptolemaic authors of the Famine text, designed to give it a specious archaic colouring? If, on the contrary, the identification rests upon a true tradition, then I see no alternative to supposing that the term $\overline{\text{𓂏}}\overline{\text{𓂏}}$ in the earliest Dynastic times referred to two heterogeneous buildings.

I

The chief source for the $\overline{\text{𓂏}}\overline{\text{𓂏}}$ is the title $\overline{\text{𓂏}}\overline{\text{𓂏}}\overline{\text{𓂏}}\overline{\text{𓂏}}$, also more shortly written $\overline{\text{𓂏}}\overline{\text{𓂏}}$, of which according to Junker, *Giza II*, 65 the Berlin Dictionary knows thirty examples, all of them of the Old Kingdom. My own collection consists of only twenty, but these seem a sufficient basis for inferences, unless Junker's mention of a variant $\overline{\text{𓂏}}\overline{\text{𓂏}}\overline{\text{𓂏}}$ applies to more than the one example in Borchardt, *Grabd. d. K. Ne-user-re*, 121, which Kees (*Re-Heiligtum*, III, 26) had interpreted in that manner. Reference to Borchardt's publication shows that the sign surrounding the $\overline{\text{𓂏}}$ is as large as $\overline{\text{𓂏}}$ and is completely destroyed on two sides. Since the owner of the tomb $\overline{\text{𓂏}}\overline{\text{𓂏}}\overline{\text{𓂏}}\overline{\text{𓂏}}$ Djedjemꜥnekh possesses (*op. cit.*, 121) several other titles which are regular concomitants of the title in question, it is extremely unlikely that the reading $\overline{\text{𓂏}}\overline{\text{𓂏}}$ is correct. Again, much stress has been laid on a supposed variant $\overline{\text{𓂏}}\overline{\text{𓂏}}\overline{\text{𓂏}}$ in Mar., *Mast.*, p. 109 (B 16). Apart from the isolated character of this variant, I doubt its existence. Mariette quotes three (or four?) legends from the tomb. One gives the name clearly as $\overline{\text{𓂏}}\overline{\text{𓂏}}$ 'Ankhyeres, a name found elsewhere. Another ends with $\overline{\text{𓂏}}\overline{\text{𓂏}}$, where, if $\overline{\text{𓂏}}$ is part of the preceding title, it is a part never found elsewhere, whereas $\overline{\text{𓂏}}\overline{\text{𓂏}}$ 'controller of the palace' belongs to the aforementioned regular concomitants of $\overline{\text{𓂏}}\overline{\text{𓂏}}$. In the third legend the ending is $\overline{\text{𓂏}}\overline{\text{𓂏}}\overline{\text{𓂏}}\overline{\text{𓂏}}$. Is it not possible that $\overline{\text{𓂏}}\overline{\text{𓂏}}$ Seshat-ꜥnkhyeres is the full name, and that $\overline{\text{𓂏}}\overline{\text{𓂏}}$ Seshat and $\overline{\text{𓂏}}\overline{\text{𓂏}}$ 'Ankhyeres are alternative abbreviations of it?¹

¹ Another possible view would be that the names Seshat and 'Ankhyeres are really distinct names. For two names for the same person immediately following one another see Junker, *op. cit.*, 112-14. In that case,

I do not understand the formation, but if the final -ś is the pronominal suffix, a suppressed element referring to a goddess might partly explain $\text{𓆎} \text{𓆏} \text{𓆐}$. In any case, it would surely be rash to rest the identity of 𓆎 with $\text{𓆎} \text{𓆏} \text{𓆐}$ on so hypothetical an association with the goddess of writing.

If we examine with care the examples of $\text{𓆎} \text{𓆏} \text{𓆐}$ we shall find that a considerable number place that title at or near the conclusion of the series dealt with by Blackman in his important article (*JEA* 5, 148 ff.) on $\text{𓆎} \text{𓆏} \text{𓆐}$ 'the House of the Morning'.¹ The inscriptions usually begin with $\text{𓆎} \text{𓆏}$ 'Unique friend', and continue with such titles as $\text{𓆎} \text{𓆏} \text{𓆐}$ 'Chief Nekhebite', $\text{𓆎} \text{𓆏}$ 'Controller of the Palace' and $\text{𓆎} \text{𓆏} \text{𓆐} \text{𓆑} \text{𓆒} \text{𓆓} \text{𓆔} \text{𓆕}$ 'Master of the secrets of the House of the Morning'. Examples where $\text{𓆎} \text{𓆏} \text{𓆐}$ is added to these or to some of them are Leps., *Dkm.*, II, 36, c; 86, b; Mar., *Mast.*, D 2, D 21, D 47, D 49; Steindorff, *Grab d. Ti.*, 26; Junker, *Giza II*, Fig. 18 opp. p. 150; Selim Hassan, *Excavations 1930-1931*, pp. 110, 190; Cairo 55 = Borchardt, *Statuen*, p. 49; Cairo 171 = *op. cit.*, p. 121; also the case discussed above from the pyramid of King Neweserrē. Now Blackman has shown that the 'House of the Morning' was the place where the king's toilet was performed, and several of the associated epithets prove that they form a factually related series arranged with some regard for a consecutive order of events. There are definite grounds for thinking that the 'Chief Nekhebite' had duties connected with the royal crowns (Blackman, *op. cit.*, 149, n. 2), and so too had the $\text{𓆎} \text{𓆏}$ 'Keeper of the royal diadem' (*Wb.*, II, 256, 17)² which, as Blackman has seen (*op. cit.*, 152), belongs to the series and is at least twice (Leps., *Dkm.*, II, 36, c; Mar., *Mast.*, D 49) in close conjunction with $\text{𓆎} \text{𓆏} \text{𓆐}$.³ Another unique epithet that points in the same direction is $\text{𓆎} \text{𓆏} \text{𓆐}$ 'beautifying Horus', i.e. the king, which occurs between $\text{𓆎} \text{𓆏}$ and $\text{𓆎} \text{𓆏} \text{𓆐}$ in the tomb of Debehni (Leps., *Dkm.*, II, 37, a).

Blackman seems to me to have overstressed the religious aspect of the House of the Morning. The temples undoubtedly possessed a chamber of that name which was the counterpart of our modern vestry, and which was used when the king himself, instead of a priest as his usual deputy, participated in the religious services. But a close scrutiny of the aforesaid series of titles makes it certain that they refer merely to the court ceremonial. The significant title $\text{𓆎} \text{𓆏}$ 'Controller of the Palace' is nearly always a constituent. Now as Blackman has not failed to point out (*op. cit.*, 160 ff.), the natural sequel to the matutinal toilet is breakfast. He does not put it exactly in those words, nor has he connected the title $\text{𓆎} \text{𓆏} \text{𓆐}$ with the king's repasts. This is the further step that I desire to take, and the corollary to be added is that the 𓆎 was that part of the palace where the Pharaoh lived and had his being; here, in particular, he must have partaken of his meals, attended no doubt by his queen and family and not impossibly by other members of his household.

however, there would be the difficulty that the feminine Seshat is a very inappropriate name for a man, unless indeed it were itself a shortening for some such name as Hetep-seshat.

¹ In Blackman's detailed enumeration he sometimes stops short before our title, which he renders 'Supervisor of the Contributions in the House of Life', is reached; cf. however his Nos. 3 (β, γ), 6 (α, β), 7, 8, 11.

² The stela Brit. Mus. 101 recently re-edited in *JEA* 21, 1 ff., is interesting as combining this with other epithets connected with the king's toilet, see *op. cit.* 4, n. 2.

³ The latter instance gives 𓆎 for *iri*, which we know to be the true reading from later variants. While Sethe's view that 𓆎 in the Old Kingdom determines the pictographic character of the sign it follows is in the main undoubtedly correct, such exceptions as this urge caution. So too in a single instance of the early Fifth Dynasty we find 𓆎 (Junker, *op. cit.*, 147), though we know from the plural $\text{𓆎} \text{𓆏} \text{𓆐}$ (e.g. Mar., *Mast.*, D 23, p. 248) and from the isolated singular 𓆎 (*op. cit.*, D 49, p. 312) that *hri* should be read. The note on the reading *Wb.*, III, 139, 1, should be reconsidered accordingly.

The space at my disposal makes it impossible to set forth at length the different series of titles among which $\text{𓄿} \text{𓄿} \text{𓄿} \text{𓄿}$ occurs, but any one who will take the trouble to look up the references above given will see that this title usually occurs *after* those relating to the king's toilet, and not seldom immediately or shortly before the personal name.¹ This position seems to me highly significant. The toilet necessarily precedes the meal, and when the meal is over little remains to be said.

I am not sure whether the title $\text{𓄿} \text{𓄿} \text{𓄿} \text{𓄿}$ 'Administrator of Praising-Horus-at-the-front-of-heaven', which occurs almost immediately after $\text{𓄿} \text{𓄿} \text{𓄿}$ in the tomb of Debehni (Leps., *Dkm.*, II, 37, *a*) and shortly before it in that of Wepemnofret (Selim Hassan, *op. cit.*, Fig. 219, opp. p. 190) may likewise have reference to the royal meal. At all events it belongs to the same series of titles, and to the latter part of it (see Mar., *Mast.*, D 2, p. 176; D 47, p. 307; D 49, p. 312), and Sethe (in Garstang, *Mahásna and Bêt Khalláf*, 21) has shown that $\text{𓄿} \text{𓄿} \text{𓄿}$ was a royal vineyard.² Hence the administrator of that vineyard may also have had the privilege of bringing its produce direct to the king's table. In more than one early inscription (Louvre B 1 and 2; Berlin 1141, 1142; see Weill, *Ile. et IIIe. dyn. ég.*, Pls. vi, vii) the title $\text{𓄿} \text{𓄿}$, *i.e.* $\text{𓄿} \text{𓄿}$ 'controller of the two seats', though not, I think, actually in the above-quoted series of titles, occurs in close connexion with $\text{𓄿} \text{𓄿}$, and the unique variant $\text{𓄿} \text{𓄿} \text{𓄿} \text{𓄿}$ 'controller of the two seats in the Mansion of Life' (Leps., *Dkm.*, II, 81) encourages us to believe that this office was connected with the throne upon which Pharaoh sat whilst eating. Since even an absolute monarch would be unlikely to occupy two chairs simultaneously, perhaps here the reference is to the respective seats of king and queen, who will have taken their meals together like any other man and wife of exalted birth; however, the usual reference of dual designations to Upper and Lower Egypt counsels caution. Another title found in company with $\text{𓄿} \text{𓄿}$ (Junker, *op. cit.*, 159; Selim Hassan, *op. cit.*, 111) or else with $\text{𓄿} \text{𓄿}$ (Leps., *Dkm.*, II, 81) is $\text{𓄿} \text{𓄿}$ 'Controller of the black wine-jar', which, if my translation is correct, tells its own tale.³

The above combinations would, however, lack their indispensable foundation unless it could be shown that the title 𓄿 was closely bound up with the notion of feasting and with the supplies for feasting. Maspero (*Études ég.*, II, 207-9) defined the function of the 𓄿 with rough accuracy as that of a 'maître d'hôtel', but in my opinion he went astray in envisaging 𓄿 as 'la chapelle du temple local qui contenait les statues du double d'un Pharaon'. The besetting sin of Egyptologists, or to speak more charitably, the inevitable result of the nature of their material, is to attribute religious or funerary import to contexts which have no need of it. It must never be forgotten that the outstanding characteristic of Egyptian ritual and belief was to set the life of the gods and the dead on precisely the same footing as the life of the living. Hence what we find enacted in religious and funerary scenes is extremely likely to have had its counterpart in any wealthy household, and particularly in that of the Pharaoh. Now Junker (*op. cit.*, 64-6) has shown with admirable clarity that Fourth Dynasty funerary repasts involved the co-operation of three officiants: (1) the 𓄿 *wdpw* or 'butler', who evidently derived his role from the service of the living, (2) the 𓄿

¹ The order may be disturbed by such factors as the division of the titles into columns, compare (*e.g.*) Leps., *Dkm.*, II, 36, *c* with *op. cit.*, II, 37, *a*, and no one who knows the habits of Egyptian tomb-designers would expect a rigid invariability in this respect.

² So too, before Sethe, Maspero, *Études ég.*, II, 267-9.

³ Junker (*op. cit.*, 161-2) discusses this title at length. On the ground of $\text{𓄿} \text{𓄿} \text{𓄿}$ *hk; bwt*, with which it is frequently associated, he connects the title with the cult of Hathor. But even if this conjecture holds, it need not necessarily waft us from the scene of the royal banquet, where Hathor, as the goddess of wine and music, had, as the story of Sinuhe shows, her own appropriate part to play.

wty or ‘embalmer’, who equally clearly was of funerary origin, and (3) the $\text{𓄿} \text{hri wdb}$. In his sensible discussion of the 𓄿 Junker weighs the possibility that the funerary function of that personage may have had nothing to do with his earthly duties. I doubt if he would have been so cautious had he realized the continuity of the series of titles studied above.

In the tombs the 𓄿 is usually shown (see *op. cit.*) facing the deceased noble with right arm stretched out to the level of the face (Pl. vi, 1). This is the gesture of ‘calling’ or of ‘address’, and since the verb $\text{𓄿} \text{wdb}$ may mean ‘to change’—the primary sense in Coptic, see Crum, *Dict.*, s.v. ⲟϣⲱⲧⲏ —no less than ‘to turn’, I thought for a moment that 𓄿 might signify the servant who changed the various courses constituting the menu. That was doubtless the function indicated by the aforesaid gesture, though in the funerary application the 𓄿 apparently did not actually mention the items themselves, but recited the appropriate formulae punning upon their names as set forth in the *Pyramid Texts*. However, Junker observes that the legend accompanying this gesture is $\text{𓄿} \text{wdb}$ or 𓄿 or $\text{𓄿} \text{wdb}$ or $\text{𓄿} \text{wdb}$ (*op. cit.*, 65; also the detailed specification, 62–3); the words $\text{𓄿} \text{wdb}$ are conspicuous by their absence. The conclusion to be drawn is that though the gesture 𓄿 represents the 𓄿 changing the courses and acting, in Maspero’s words, as the *maître d’hôtel*, nevertheless this is not the exact function expressed in the name 𓄿 . As regards the reading of that title, the interpretation of 𓄿 as *hri* has already been justified (above p. 84, n. 3). The element 𓄿 is undoubtedly to be read *wdb*. Not only is *wdb* a technical term in connexion with offerings, but also the pun in the Ramesseum dramatic papyrus 125 (Sethe, *Dramatische Texte*, 227) is conclusive. There, as the officiant named $\text{𓄿} \text{hri}$ comes into play, the words $\text{𓄿} \text{wdb}$ are spoken, being supposed to be addressed by Horus to Seth. We are not concerned with the meaning of that utterance; its only interest to us here is that it proves the reading *hri wdb*. That Sethe’s attempt to interpret the title 𓄿 as ‘with turned face’ was a mistake is proved by the reading of the first element as *hri*. To take *wdb* in this title as the word for ‘shore’, which is the view adopted by *Wb.*, I, 409, 4 and hesitatingly also by Kees, *Kulturgeschichte*, 22,¹ is in the last degree improbable, since *wdb* ‘shore’ refers to a tract of sand rather than to cultivated fields, and if, as seems likely from the fact that the 𓄿 appears to have superintended the official ‘counting of the cattle’,² he was concerned not merely with the royal banquets, but with the supplies for the same, a sand-bank surely is a very unlikely source for the best vegetables.³ For these reasons I am strongly of opinion that Junker, *op. cit.*, 65 is right in taking *wdb* in our title as the infinitive or as a *nomen actionis* from $\text{𓄿} \text{wdb}$ in connexion with offerings—he renders ‘zuwenden’ or ‘Zuwendung’—and this suggestion is reinforced by the fact that the single sign 𓄿 occurs at least twice as an abbreviation for that verb, see $\text{𓄿} \text{wdb}$ *Pyr.*, 115, c; $\text{𓄿} \text{wdb}$ Bissing, *Gem-ni-kai*, II, Pl. 30 (see below).

Fortunately we are not without evidence to show what the verb *wdb* means in its technical funerary sense. There are two scenes (Pls. v; vi, 2) where this verb is written above an officiant at a funerary banquet. The Sixth Dynasty representation from the tomb of Kagemni (Pl. v) is more eloquent and lavish of detail than such scenes are wont to be. To the left (*op. cit.*, Pl. 27) sits the great man before a table of offerings over which, as is seen from the identical set of scenes on the opposite wall (Pls. 16–19), was once inscribed the complete *menu*, i.e. the now stereotyped longer list of offerings. Before him to the right (Pl. 29) a

¹ Kees formerly read the word as *hri* ‘fields’, see Bissing-Kees, *Untersuchungen zu den Reliefs aus dem Re-Heiligtum*, 21.

² *Op. cit.* (in the last note), 20.

³ The passages quoted by Kees, *op. cit.*, 21 show at least that the ‘scribes of the house of the *hri wdb*’ (see below) were often simultaneously ‘scribes of the fields’.

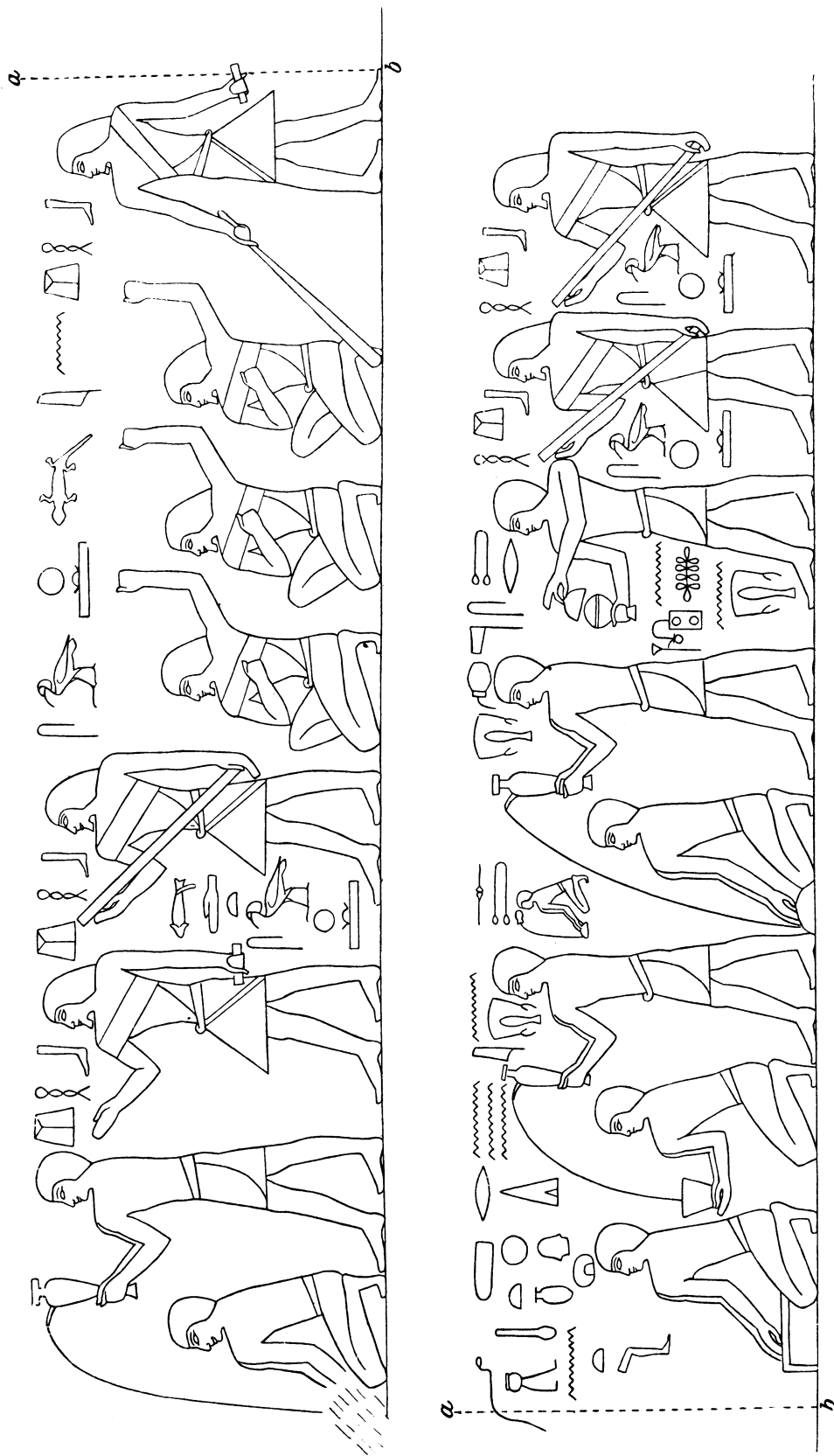

FROM THE TOMB OF KAGEMNI

Redrawn by Miss Broome from Von Bissing, *Mastaba des Gem-ni-kai*, II, Pls. 29-31, cf. Pls. 18-19

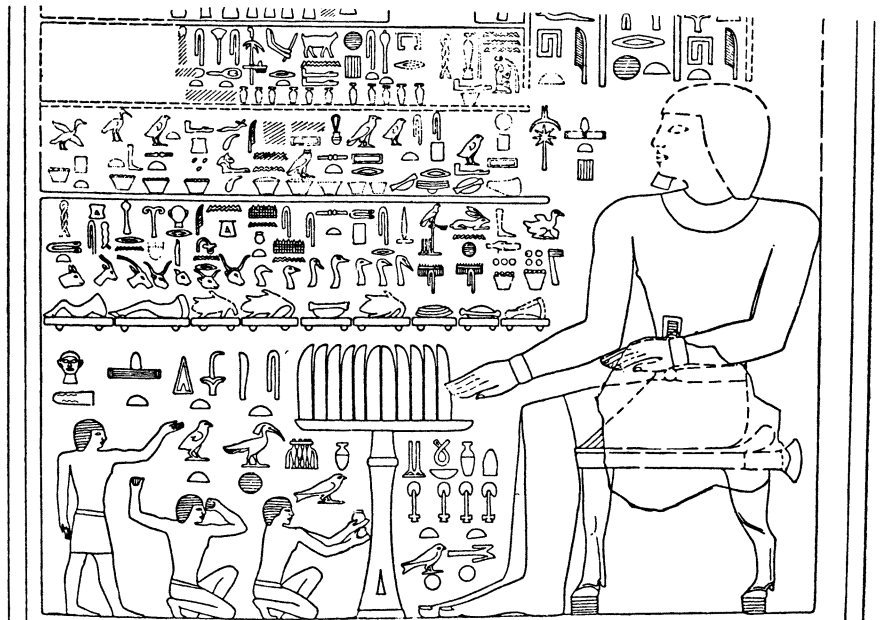



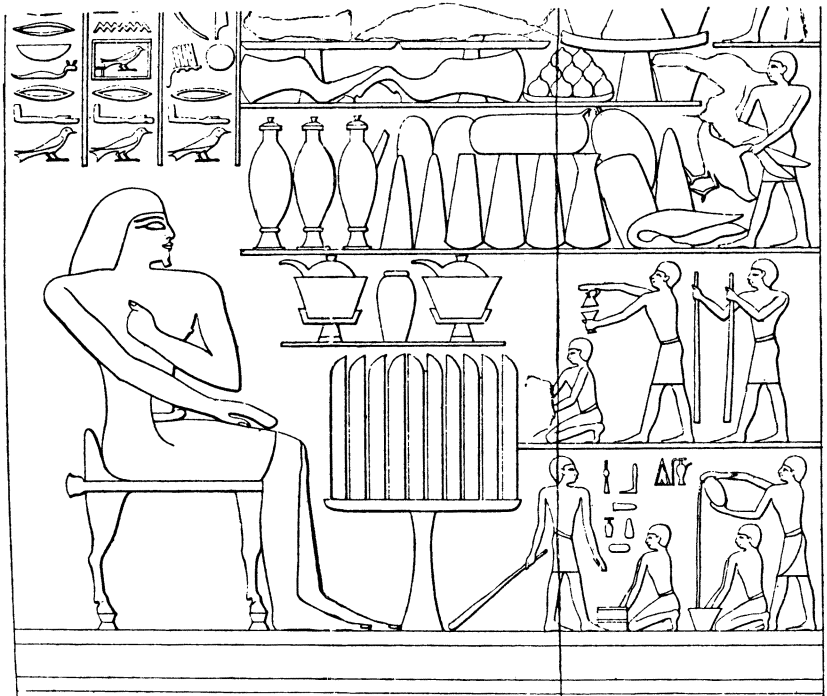







1



2

FUNERARY RITES FROM TWO FIFTH DYNASTY TOMBS

1. From the tomb of Hetpseshet, Junker, *Giza II*, p. 187, Fig. 33
2. From the tomb of Ra^cwēr, Leps. *Dkm.* II, 84

priest pours water from a tall jar over the hands of a kneeling man, and the logic of the situation demands that the latter should be either Kagemni himself, or a *ka*-priest impersonating him.¹ For this is the rite of  'water-pouring' with which every feast began, and it cannot be doubted that the hands therein to be washed were those of the beneficiary himself, not of those attending upon him. The subsequent events follow in cinematographic fashion. Two 'lector-priests' () or it may be the same one performing his function in alternative manners, recite the appropriate spells or read them from an extended papyrus-roll. The three kneeling figures shown in the attitude  are probably echoing those spells to a breast-thumping accompaniment. The earlier counterparts to this scene, of which Pl. vi, 1 gives an example, attribute these ceremonial acts to the  *hrī wdb* and to the  'embalmer' respectively. Further to the right in the tomb of Kagemni (*op. cit.*, Pl. 29, *cf.* 19) is the lector-priest again, his feet turned in the opposite direction and trailing behind him the long brush known from later texts to have been made of the *hḏn*-plant. This, as indicated by the legend  'Recitation. Removing the foot', is the well-known rite performed when the ceremonies connected with the daily ritual of the dead or of the gods were brought to a close, when in fact the officiating priest left the cult-chamber.² Thus far the scenes in the tomb of Kagemni are in no way abnormal; the foot-removing priest is seen again, *e.g.* in the tomb of Ptaḥhotpe (Paget-Pirie, Pl. 38) and elsewhere (for references see Klebs, *Reliefs d. alten Reiches*, p. 138, n. 4; *d. mittl. Reiches*, p. 107). What is, however, entirely abnormal in Kagemni is that the figure of the departing lector-priest is followed by other figures enacting the hand-washing and the reciting of the spells all over again, only with some variation of the details (*op. cit.*, Pls. 30, 31, *cf.* too 19; redrawn thence by Miss Broome, Pl. v). How is this repetition to be explained? Hardly as a renewal of the rites before Kagemni later on the same day. The words  *wdb iht* over the first kneeling man give the clue, and the same expression  is found in the much earlier representation of the foot-removing priest shown in Pl. vi, 2. In the last-named scene the priest in question even turns his face away from the owner of the tomb, thus giving all his attention to the man kneeling in front of him, hands stretched out over a small table ready to receive the purifying flow of water. From various Old Kingdom texts it has been conjectured that *wdb iht* means 'diversion of the food-offerings' from one beneficiary to another.³ We know from many sources that food-offerings laid before the gods in their temples were subsequently taken thence and used for the benefit of the dead. Surely the scene in the tomb of Kagemni must indicate that the funerary gifts laid before him—in part, no doubt, as a  from the king—were afterwards transferred to others who thus virtually became guests of his. We now understand how in the underground chamber of this same tomb the last item in the great offering-list is labelled  'An offering which the king gives. Diversion of the food-offerings'⁴ and why elsewhere (*e.g.* Murray, *Saqqara Mastabas*, I, Pl. 18) the final items should be just those same items of hand-washing, censuring, and fumigation which opened the entire ritual. The explanation evidently is that when the food-gifts from the royal

¹ The latter alternative seems proved by Paget-Pirie, *Tomb of Ptahhetep*, 38, where the kneeling figure receives a proper name of his own. It is significant, however, that in Middle-Kingdom tombs the priest simply pours the water over an altar, no second officiant being present, see Newberry, *Beni Hasan*, I, Pl. 18; Davies, *Antefoker*, Pl. 28. Since the tomb-owner was dead and buried far away underground, in the funereal rite the hand-washing had either to take the semblance of a mere libation, or else to be performed upon a deputizing *ka*-priest. On the other hand, in the *depiction* of this act the tomb-owner might well have been sometimes intended.

² See Excursus II in Davies-Gardiner, *Tomb of Amenemḥēt*, 93-4.

³ Firth-Gunn, *Teti Pyramid Cemeteries*, p. 125.

⁴ *Op. cit.*, p. 124.

the official who presided over the royal meals in the king's 'Mansion of Life', his living- or dining-room, was also the official in charge of the $\text{𓆎} \text{𓆏} \text{𓆐}$, the gifts given by the king.¹ It will be seen how different this conclusion is from Kees's conception of a 'Domänenverwalter' who carried on his avocation in the 'Gelehrtenschule' known as the 'House of Life'.² Nor have I found much evidence which could justify Pirenne's definition of the 𓆏 as the official 'qui dirigerat, sous les dynasties memphites, les bureaux de l'impôt',³ though no doubt the king's kitchen was supplied largely from forced contributions from which, as at Coptos, a temple might be dispensed by royal decree.

II

Four times in the Pyramid Texts the Mansion of Life is named in connexion with the obscure goddess $\text{𓆎} \text{𓆏} \text{𓆐}$ Mafdet (*Wb.*, II, 29, 6) who is said to dwell there; the epithets in question are $\text{𓆎} \text{𓆏} \text{𓆐}$ *Pyr.*, 440, c; $\text{𓆎} \text{𓆏} \text{𓆐}$ *Pyr.*, 677, d; 685, d; with the name of the goddess suppressed, *Pyr.*, 672, b; cf. also at Edfu, *Leps.*, *Dkm.*, IV, 46, a, 26 $\text{𓆎} \text{𓆏} \text{𓆐}$. In all these passages this cat-like goddess is represented as killing a snake with her paw, and the context is a spell for protection against serpents. In the Pyramid Texts the spell is of course applied to the protection of the dead king, but it seems very likely that this application is secondary and that the original intention of the spell was to benefit the living Pharaoh. If so, $\text{𓆎} \text{𓆏} \text{𓆐}$ may here once again designate nothing more than the living-rooms of the royal palace, and the goddess will represent either a real or imaginary creature kept for the purpose of hunting venomous snakes. One thinks of the mongoose, of which, as Dr. Fraser of the Natural History Museum tells me, many mummified specimens are found in that Museum mixed up with the mummified cats. It is a serious difficulty that Mafdet as depicted on a very ancient monument (Petrie, *Royal Tombs*, I, Pl. 7, 4 recognized as part of *op. cit.*, II, Pl. 7, 10⁴ by Sethe in Borchardt, *Sahure*, II, 78) looks more like a cat (so Schäfer) or panther (so Sethe) than a mongoose; and, as Faulkner suggests, does not a mongoose kill rather with its mouth than with its claws? On the other hand, the equally early representation (*op. cit.*, II, Pl. 7, 7; cf. Palermo Stone, *rt.*, 3, 13) of the animal running up a 𓆎 -sign is passably like a mongoose.⁵ Miss Broome and Miss Calverley tell me, however, that their cat at to the land-designation *idb*. We must bear in mind that in the Middle Kingdom the officer connected with the Royal Table was known as $\text{𓆎} \text{𓆏} \text{𓆐}$ $\text{𓆎} \text{𓆏} \text{𓆐}$, apparently *wrtw n 𓆎 hks* (Lange-Schäfer, *Grab- und Denksteine*, III, 55-6), the correlative term for the recipient being $\text{𓆎} \text{𓆏} \text{𓆐}$ $\text{𓆎} \text{𓆏} \text{𓆐}$ (*op. cit.*, 53).

¹ Junker, *op. cit.*, 76 quotes with qualified favour Sethe's view (*Dramat. Texte*, 209, n. 1) that this expression originally meant 'der König sei gnädig und gebe'. I fail to find a particle of evidence for the notion that this phrase ever incorporated a wish, and the said interpretation ignores the connexion with *htp niswt* and *htp wšht* upon which Junker himself (p. 77) lays stress. In translating *htp* as 'boon' rather than 'food-offering' (Davies-Gardiner, *op. cit.*, 80) I had in view the fact that good burial, &c., are sometimes intended by the gift, but I would now admit that the Egyptian might have said 'offering' while he meant a good burial. For the word-order *htp (r)di(w) niswt* my philological account (*loc. cit.*) overlooked *Pyr.*, 1651, which proves it. Otherwise there is hardly a word which I should wish to alter in what I there wrote. Sethe seems to have underrated the importance of the conception of food-transference to which the present article is mainly devoted, and his explanation of the variant $\text{𓆎} \text{𓆏} \text{𓆐}$ *Pyr.*, 1019 as containing the *w* of the *šdm.f* form before nominal subject is very improbable. I should now describe the form *rdi(w)* rather as a perfective passive participle than as a relative form. The original sense of the expression, as I now see it, is to be sought in the words of the *hri wdb* as he stands before the recipient of the royal gift, alive or dead; what he says is 'An offering given by the King', a virtual predicate to the present he brings with him.

² Kees, *Kulturgeschichte*, 22, 190-1.

³ Pirenne, *Histoire des institutions*, I, 122, 162, n. 5.

⁴ Note the interesting fact that here Mafdet is pictorially represented as 'lady of the Mansion of Life'.

⁵ In particular, the legs are not those of either a cat or a panther.

Abydos killed several horned vipers by first pouncing upon them with her claws and then biting them. In face of this evidence it seems to me preferable to suppose that Mafdet was really a cat-goddess.

III

For my remaining examples of $\overline{\text{𓏏}}$ I am dependent on Gauthier, *Dict. géogr.*, iv, 55, since it has been impossible for me to search through the vast body of Graeco-Roman texts where the expression might conceivably be found. In Chassinat, *Edfou*, II, 92, 98 among other epithets of Horus he is called $\overline{\text{𓏏}}$ $\overline{\text{𓏏}}$ $\overline{\text{𓏏}}$ $\overline{\text{𓏏}}$ $\overline{\text{𓏏}}$ $\overline{\text{𓏏}}$ 'he of Behdet dwelling in the Mansion of Life', and similarly at Denderah (Mar., *Dend.*, I, 26) Hathor is named $\overline{\text{𓏏}}$ $\overline{\text{𓏏}}$. One may well ask whether these phrases mean more than 'in his (or her) own home'. Of Hathor it is said $\overline{\text{𓏏}}$ $\overline{\text{𓏏}}$ 'she makes great the Mansion of Life' (Dümichen, *Tempelinschr.*, II, 18, 8), which I am tempted to interpret as meaning that she increases the importance of the temple where she is at home.

Thus, with the sole exception of the passage from the Famine Stela, there seems no valid reason for identifying the $\overline{\text{𓏏}}$ 'Mansion of Life' with the $\overline{\text{𓏏}}$ 'House of Life', *i.e.* the workshop of the *ἱερογραμματεῖς*. Sufficient evidence has been produced to make it highly likely that, except in the one instance just mentioned, the $\overline{\text{𓏏}}$ was just that place where a Pharaoh or a god lived. It is not impossible, however, that the notion of 'Life' contained in this compound term was more materially conceived than it would be with ourselves; it may well have been consciously associated with the thought of 'victuals'.

NOTE

The evidence as to the exact nature of the action often seen in representations of funerary rites, where a standing man pours out water, is somewhat conflicting. Most often he stands behind a man kneeling with his hands outstretched before him. In Leps., *Dkm.*, II, 84, and also in *op. cit.*, *Ergänzungsbd.*, Pl. 31, the kneeling man has his hands in a bowl $\overline{\text{𓏏}}$, and the water is being poured over them. In Davies, *Ptahhetep*, II, Pl. 31, the water is falling directly on to the kneeling man's hands. Similarly in the sign *syt*, *Pyr.*, § 1011, *a*, N-text, first occurrence; and so in the scene described on pp. 86-7 above. Such examples indicate that hand-washing is the action performed. But in the sign *syt* as given in two cases in Leps., *Dkm.*, II, 38, and twice in *Pyr.*, § 1981, *a*, the water falls in front of the kneeling man's hands; similarly in Paget-Pirie, *Ptahhetep*, Pl. 9, where the water falls on an object $\overline{\text{𓏏}}$. In *El Bersheh*, I, Pl. 11, however, the water is poured (*syt*) on to the ground before the deceased's feet, and in Junker, *Giza II*, Abb. 29, a similar act is being performed. As Dr. Gardiner has noted (p. 87, n. 1), sometimes the water is merely poured over a table (?), no second officiant being present; in *Gem-ni-kai*, II, Pl. 19, and in the sign *syt* in *Pyr.*, § 1011, *a*, P-text, as in the same sign, *Gem-ni-kai*, II, Pl. 30, the water falls on to an object $\overline{\text{𓏏}}$ of obscure nature. In *El Bersheh*, I, Pls. 32, 34 show scenes similar to those in *Gem-ni-kai*, II, Pls. 19, 30: at the back a kneeling man, with hands placed over a small table with single tall foot, has water poured (*syt*) on to them by a standing man; in front of this scene is a kneeling man holding a bowl $\overline{\text{𓏏}}$ into which water is poured in the usual way, the action being described as $\overline{\text{𓏏}}$ $\overline{\text{𓏏}}$ (= $\overline{\text{𓏏}}$ $\overline{\text{𓏏}}$ in Kagemni); in front of this again is a kneeling man, with no water-pourer standing behind him, his hands resting on an object $\overline{\text{𓏏}}$.

In *Pyr.*, § 16, *a-d*, is the spell to be recited during the rite *syt* (written with a pot pouring water on to an object $\overline{\text{𓏏}}$, but unfortunately little is to be gleaned from this as to the nature of the rite. 'O Osiris, take thou away¹ all those whom K. hates,² and who have spoken evilly against his name.

¹ Or 'thou hast taken away', or 'I take away for thee'.

² Or 'who hate K.'.

O Thoth, carry off him who has injured¹ Osiris; fetch him who has spoken evilly against the name of K. Put thou him² into thy hand (*four times*); let not thyself be separated from him!³ Beware! be not separated from him!' If this is a rite of washing the King's hands the spell perhaps identifies the King's slanderers with the water poured over (and into) his hands.

B. G.

¹ So Sethe in *ZÄS* 54, 31. Sethe does not, however, refer to this passage in his discussion of *šw* in *Übers. u. Komm. z. d. . . . Pyramidentexten*, to § 611, *a-b*. However, to take *šw* here as 'him' would be difficult, since there is no possible antecedent.

² Or 'I put him for thee'.

³ Similarly of Seth, *Pyr.*, § 642, *b*; *cf.* § 43, *a*.

BIBLIOGRAPHY: GRAECO-ROMAN EGYPT

PAPYROLOGY (1937)

The work is divided as follows:

- § 1. Literary Texts. E. A. BARBER, Exeter College, Oxford.
- § 2. Religion, Magic, Astrology (including texts). H. J. ROSE, St. Andrews University, Fife, Scotland.
- § 3. Publications of Non-Literary Texts. T. C. SKEAT, Dept. of MSS., British Museum, London, W.C. 1.
- § 4. Political History, Biography, Administration, Topography, and Chronology. E. G. TURNER, King's College, Aberdeen, Scotland.
- § 5. Social Life, Education, Art, Economic History, Numismatics, and Metrology. J. G. MILNE, 23 Bel-syre Court, Woodstock Road, Oxford.
- § 6. Law. H. F. JOLOWICZ, University College, Gower Street, London, W.C. 1.
- § 7. Palaeography and Diplomatic. T. C. SKEAT.
- § 8. Lexicography and Grammar. L. R. PALMER, The University, Manchester.
- § 9. General Works, Bibliography, General Notes on Papyrus Texts. T. C. SKEAT.
- § 10. Miscellaneous, Excavations, Personal. T. C. SKEAT.

The authors wish jointly to express their gratitude to all those scholars who have sent them copies of their publications, a kindness which has greatly facilitated the work of compilation.

The abbreviations of references used in this and the following Bibliographies will be found among those given in vol. 23, pp. 142-4; to these must be added: *Arch. hist. dr. or.* = *Archives d'histoire du droit oriental*; *Bull. Ass. am. art copte* = *Bulletin de l'Association des amis de l'art copte*; *Forsch. u. Fortschr.* = *Forschungen und Fortschritte*. For other abbreviations see vol. 23, p. 230, n. 1, with the addition of the following: Cop. = Coptic; doc(s). = document(s); edn. = edition; pap(p). = papyrus, papyri; revr. = reviewer; Rom. = Roman.

[The date '1937' is omitted in the case of books, periodicals, etc., published in that year.]

I. Literary Texts

A. GENERAL

In *Euripides Alexandros u. andere Strassburger Papyri mit Fragmenten griechischer Dichter* (Berlin) B. SNELL covers a wide field. On pp. 1-68 he republ. the fragm., old and new, of the *Alexandros* and tries to reconstruct the play; cf. the dissertation (Münster, 1936) of CHR. LEFKE, *De Euripidis Alexandro*. Pp. 69-92 are concerned with the pap. containing lyrics from Tragedy publ. after CRÖNERT by N. LEWIS in *Ét. de Pap.* 3 (1936), 46-92; SNELL offers additions and corrections, especially for the *Medea*, and a new text of the third piece, which he doubtfully assigns to the *Melanippe ἡ σοφῆ*. There follows a new text of the Messenger's Speech contained in the same pap., describing the duel between Hector and Achilles, which SNELL would assign to the *Hector* of Astydamos. On the verso of this pap. are extracts from an anthology. SNELL gives MAAS's text of two pieces: (1) eleven lines of Philemon = Fr. 89 K., (2) a Spartan Paean to Eurys, and nn. on the remaining extracts. Pp. 93-111 contain the following texts: (1) Inv. gr. 2340 (3rd cent. B.C.), scraps of Early Elegy; (2) Inv. gr. 1406-9 (2nd cent. A.D.), from Simonides' *epinicia* for runners; (3) Inv. gr. 1348, perhaps Comedy; (4) Inv. gr. 2345 (3rd cent. B.C.), Comedy: *ibid.* verso, perhaps Comedy; (5) Inv. gr. 1313 (3rd cent. A.D.), hymn of *Mystae in asynarteta*. Most of the above pieces had been partially publ. by CRÖNERT, but the present edition is far fuller and altogether more satisfactory.

In *Riv. di fil.* 14 (1936), 385-409, F. DELLA CORTE discusses the following eight papp., some of which have not been previously edited: (1) P. Berl. 9870-9871, assigned to a Hesiodic 'Catalogue of Women' (on these two papp. see the same writer in *Riv. di fil.* 15, 42-5); (2) P. Berl. 9809. Citation of Plat. *Phileb.* 16 d-17 a identified in col. 1; (3) P. Berl. 9879 (P. Reinach 5), tract on music; (4) P. Berl. 8439, post-Aristotelian grammatical fragment; (5) P. Berl. 10580 (PBC 3, 6731), two papp. of Dioscoros of

Aphrodito; (6) P. Berl. 9766 (P. Oxy. 23), abridgement (? by Aristotle) of Plato, *Laws*; (7) P. Würzb. 19. Marcus Seius Nicanor (1st cent. B.C.) claimed as author of this tract *περὶ τρόπων*, cf. Varro, Fr. 60.

Michigan Papyri, vol. III (Ann Arbor, 1936), contains four literary papp., the first two of which have been already publ. No. 139 comprises 18 lines of a 'Hesiodic' nature. No. 140 = Soph. *O.C.* 136-46. Note 138 *ὄρᾶν* omitted, 143 *ἀλεξηρωρ*. No. 141 = Thuc. VII. 57. 11. Eclectic text. In l. 3 the pap. confirms REISKE'S emendation *κατελιγμένον*. No. 142 = Dem. *Contra Aristocratem*, [636] 51-[637] 54.

I have not yet seen A. VOGLIANO, *Papiri della R. Università di Milano, Volume primo* (Milan).

B. EPIC, ELEGIAC

In *Mnemosyne* 5, 62-8, B. A. VAN GRONINGEN publs. a fragmentary glossary to *Iliad* ix. 454-68 from a pap. (? 1st cent. A.D.) = No. G 99 vs. in the collection of E. VON SCHERLING (Leyden). Lines 458-61 of the vulgate are missing (see ALLEN'S note in the app. crit. of the Oxford Classical Texts edn.). In *Philologus* 46, 1-18, R. PFEIFFER deals first with the fragm. of a mythological poem publ. by NORSA and VITELLI in *St. it. fil. class.* 12 (1935), 87-91, and argues that these 23 hexameters come from the Great Eoiai, or, less probably, from the five Books of the Catalogues. P. Tebt. 271 has a similar origin. Secondly, he assigns the first *ιστορία* in PSI 1173 to *Odyssey* iii. 4 (not xi. 281, as COPPOLA had stated), and restores the text accordingly. Thirdly, he identifies Cat. BM 142 as a comm. on *Iliad* ix. 447.

E. DIEHL has written two arts. (*Wien. St.* 54 (1936), 143-7, and *Abh. d. Herder-Gesellschaft zu Riga*, 5. Bd. Nr. 9) on Callimachus' style, and K. ZIEGLER in *Die Antike* 13, 20-42, discourses on the poet's treatment of women. The book of J. COMAN, *L'Art de Callimaque et de Catulle dans le poème 'La Boucle de Bérénice'* (Bucarest, 1936), contains little that is new. The study of M. DE COLA, *Callimaco e Ovidio* (Palermo), is a useful collection of parallels. I have not seen the art. of L. CASTIGLIONI in *Rend. R. Ist.* 70, 155 ff., containing observations on the text of the *Diogeseis*. An article by W. KLINGER in *Munera philologica L. Cwiklinski oblata* (Posnaniae, 1936), 35-9, deals with the text of Euphorion.

C. LYRIC

The outstanding event of the year has been the publi. by MEDEA NORSA in *Ann. R. Sc. Pisa*, 6, 8-15, of an ostr. (2nd cent. B.C.) containing four stanzas of Sappho in sixteen lines preceded by another line, transcribed by the editor as *ορρανοθεν †κατιον*, which may represent the end of another stanza—and perhaps of another poem. The new text is partially covered by two known fragmm., Diehl 5 and 6 = p. 52, 6 L, and p. 18, 6 L, which it completes and corrects in certain points. Unfortunately, owing to the fragmentary condition of the ostr. and the carelessness of the scribe, much of the text remains very obscure. The poem describes a precinct and altars in 'idyllic' surroundings—apple-trees, roses, the murmur of cool water, the slumber induced by flickering leaves, etc.—and ends with a prayer to Cypris to attend as cupbearer. In l. 2 NORSA reads *ὑμμε, Κρήτες*, and connects the poem with a hypothetical visit of Sappho to Crete during her exile. But R. PFEIFFER in *Philologus* 46, 117-25, expresses his disbelief in this address to the Cretans. The same scholar interprets *κατιον* as possibly *Σαφροῦ[ς ἄλλο μέρος]*, and in l. 1 of stanza 4 retaining *ἔθα δὴ σύ*, the reading of the ostr., against *ἔλθε δὴ σύ* read by NORSA after Athen. xi. 463 e *ἔλθε, Κύπρι*, postulates a fifth stanza beginning *τοῖοδε τοῖς ἔμοιο' ἐτάροιαι καὶ σοῖς, | ἔλθε*, cf. Athen. *loc. cit.* Altogether the new find raises some pretty problems.

C. THEANDER in *Eranos* 34, 49-77, continues his *Studia Sapphica* with a discussion of \bar{a} 12, $\bar{\epsilon}$ 3, and $\bar{\epsilon}$ 5, and adds some notes on Sappho's art. In *St. it. fil. class.* 14, 139-50, W. FERRARI treats of a reminiscence of Sappho (2. 7 ff. D) in Lucretius (3. 154 ff.), and in *Atene e Roma* 38 (1936), 221-42, G. FERROTTA writes an appreciation of Alcaeus. TH. REINACH and A. PUECH are responsible for the Budé edn. (Paris) of Alcaeus and Sappho, and B. LAVAGNINI has publ. *Aglaia* (Turin), a new anthology of Greek Lyric from Callinus to Bacchylides. In *Cl. Quart.* 31, 94-101, D. L. PAGE examines instances of irregular division in a strophic chorus and claims that Alcman's *Partheneion* is sung by the whole chorus. He adds nn. on ll. 45 ff. and ll. 58-9. The same poem forms the subject of an art. by F. SCHWENN in *Rh. Mus.* 86, 289-315.

D. DRAMA

In *Phil. Woch.* 57, 558-60, W. MOREL discusses the tragic fragm. publ. by E. LOBEL in *Greek Poetry and Life* (Oxford, 1936), 295-8, and assigns it to a tragedy, which was the model of Ennius' *Andromacha Aechmalois*, possibly by Antiphon. In *Cl. Quart.* 31, 178-81, D. L. PAGE publs. parts of two cols. (3rd cent. B.C.) from a tragedy, which may be Euripides' *Meleagros*. *Ibid.* 32 (1938), 45-6, the same scholar publs. two fragmm.

(1st–2nd cent. A.D.) from Euripides' *Medea* (Fr. 1 = ll. 1165–77, Fr. 2 = 1156–60 and 1191–9); these latter fragmm. are now said by J. E. POWELL to belong to the same pap. as P. Harr. 38. In *Hermes* 72, 239–40, H. LUCAS uses Favorinus, *Περί Φυγῆς*, 2, 36 ff. to prove that Eur. Fr. 157 and 158 (from the prologue to the *Antigone*) are continuous. The reading *εὐρυχῆς* in Favorinus' citation and that of Dio Chrysostom (*Or.* 64, 6) supports the attribution of this speech to Favorinus. *Ibid.*, 466–9, H. KLOESEL proposes *ἐνωάζουσα* in l. 7 of the *Niobe* fragm. with the meaning 'über etwas oh sagen'. *Classical Studies presented to Edward Capps* (Princeton, 1936), 14–23, contains an art. by W. N. BATES on *The Satyr Dramas of Sophocles* with special ref. to the *Ichneutae* pap. W. SCHADEWALDT, writing on the *Achilleis* of Aeschylus (*Forsch. u. Fortsch.* 13, 19–20), stresses the modernity of Aeschylus' treatment. The *Neue Fragmente d. Aischylos u. Sophocles* of FRITSCH has been revd. at length by ZIMMERMANN in *Phil. Woch.* 57, 737–48.

In *Hermes* 72, 50–77, A. KOERTE publs. a new text and app. crit. of Menander's *Fabula Incerta*, i.e. the fifth play in the Cairo pap., with a full comm. He claims that the piece is in Menander's more mature style, and argues that neither P. Oxy. 429 nor PSI 1176 come from this play, the latter being possibly Philemon's work. In *Am. Journ. Phil.* 58, 456–7, H. FRAENKEL asserts that Men. *Epiir.* 1–5 'mean exactly what they say'. Charisius buys the most expensive wine and then he has even (*καί*) to force it down his throat. In *Hermes* 72, 123–7, A. LESKY argues that Men. *Theoph.* 25–30 prove the survival in Menander's day of the low stage with easy access to the orchestra. In *St. it. fil. class.* 14, 151–66, K. BUECHNER discusses Epicurus' influence on Menander. E. A. DUPARC has written a dissertation (Amsterdam) on Menander's female characters. In *Mnemosyne* 5, 53–61, G. ZUNTZ prints a new text of P. Berl. 11771 (comedy ascribed to Alexis) and discusses the piece. In *Cl. Phil.* 32, 44–58, P. W. HARSH writes on *Angiptorum*, *Platea*, and *Vicus*. *Phil. Woch.* 57, 1073–80, contains a rev. of WEHRLI's *Motivstudien zur griechischen Komödie* by E. WUEST, and *ibid.* 1029–44 of KUIPER's *Grieksche origineelen en Latijnsche navolgingen* by A. KLOTZ.

E. PHILOSOPHY, ORATORY, ROMANCE

In *Archiv* 12, 175–8, J. E. POWELL prints a fuller text of P. Harr. 1 in the light of its identification with Musonius' tract *εἰ πάντα τὰ γινόμενα τέκνα θρεπτέον* (Stob. *Flor.* 75, 15 = Musonius, Fr. 15 A). P. Harr. 12 has been identified by MAAS as from Plato, *Alc.* i. 107 c ff. In *St. it. fil. class.* 13 (1936), 267–81, A. VOGLIANO discusses a fragm. (P. Berl. Inv. 16369) of a new *Gnomologium Epicureum*. The dissertation of B. HAESLER on Favorinus, *Περί Φυγῆς*, has been revd. by H. R. SCHWYZER in *Gnomon* 13, 329–31.

In *Rend. R. Ist.* 70, 129–32, I. CAZZANIGA publs. an Oxyrhynchus pap. (1st–2nd cent. A.D.) containing Aeschines, *In Ctesiph.*, 86 ff. The text agrees with the tradition of A. In *Wien. St.* 55, 68–78 H. OELLACHER publs. a rhetorical catechism from Pap. Graec. Vind. 754 (5th–6th cent. A.D.) with an interesting comm.

B. E. PERRY in *Studies in the Text History of the Life and Fables of Aesop* (Haverford, Penn., 1936), 39–70, deals with the texts of the pap. fragmm. His book has been revd. by A. HAUSRATH in *Phil. Woch.* 57, 770–7. In *Aeg.* 16 (1936), 225–56, H. ZEITZ traces the hist. of the *Aesoproman* in the light of the papp. In *Symb. Oslo.* 15–16 (1936), 101–10, F. ZIMMERMANN publs. a fuller text and study of PSI 725 = No. 11 in his *Griechische Roman-Papyri* (Heidelberg, 1936). W. E. BLAKE has publd. *Charitonis Aphrodisiensis de Chaerea et Callirhoe Amatoriarum Narrationum libri octo* (Oxford, 1938).

F. MISCELLANEOUS

In *Symb. Oslo.* 17, 103–6, under *Varia* 82, S. EITREM emends P. Oxy. 425 and 1383 = *Coll. Alex.*, *Lyrica Adespota* 32 and 33. In *Arch. f. Rel.* 34, 313–22, he reprints with interesting nn. the two verse epitaphs on Isidora of Hermupolis, publd. by GRAINDOR in *Bull. Inst. fr.* 32 (1932). In *Mél. Maspero* 2, 265–81, A. WILHELM discusses three Gk. epigrams from Eg. The art. of Q. CATAUDELLA in *Atene e Roma* 38 (1936), 176–84, contains an appreciation of Nonnus.

In *Wien. St.* 55, 95–106, H. GERSTINGER prints fragmm. of two papp., P. Graec. Vind. 30885 a and 30885 e (4th–5th cent. A.D.), containing part of Cicero, *In Catil.* I, with a Greek word-for-word transl. The Latin text presents some points of interest.

2. Religion, Magic, Astrology

A. GENERAL

A *Festschrift* remarkable for its immense variety of contents is entitled *Quantulacumque: Studies presented to Kirsopp Lake by Pupils, Colleagues and Friends* (London, Christophers). Many of the arts. contained in it have no bearing on the present subject, but several have, and will be mentioned in their proper

places. So much importance often attaches to the precise form (*uolumen* or *codex*) of our material that the new examination by H. A. SANDERS of the date at which the latter became common cannot but be welcome. It is his presidential address to the American Phil. Ass. at their December meeting in 1937, and is published in *Univ. of Mich. Quart. Rev.* 1938, 95. He would make the *codex*-form already fairly common for all kinds of literary works (not merely for cheap editions, rough note-books, and so forth), as early as the beginning of the Christian era. Incidentally, he finds (110) that to suppose a *codex*-form for Mk. gives a much easier explanation of the loss of its concluding section than if we imagine it to have first appeared as a *uolumen*. Quite a number of arts. and monographs, not specifically dealing with anything papyrological or Egn., should nevertheless be taken account of as parallel studies, often throwing light on these. Merely as examples may be mentioned K. KERÉNYI's pamphlet, *Pythagoras u. Orpheus* (Berlin, Die Runde), which contains some interesting ideas on the difference between these two mystic disciplines; G. W. ELDERKIN's ingenious study of the marriage of Zeus and Hera and its symbol in art, *AJA* 41, 424; R. P. ECKELS's dissertation on *Greek Wolf-Lore* (Philadelphia, for the Univ. of Pennsylvania), which handles a group of beliefs so wide-spread that the papyrologist cannot neglect them; and C. W. VOLLGRAFF's suggestion regarding the provenance of the Rom. belief that the Palladium was in the shrine of Vesta (in *Bull. Acad. roy. de la Belg.*, 1938, 34), whereof he finds a trace in Kallimachos. It goes without saying that the new vols. of *PW* contain, like their predecessors, much that is relevant.

B. CULTS OF THE GRAECO-ROMAN PERIOD

Just on the border-line between religion and literature is the study by F. DELLA CORTE of the ancestry of the legend of Perseus as told by Ovid (*Riv. di fil.* 15, 42, cf. 14 (1936), 385); he supposes it to be derived from the Hesiodic *Ehoiai*. C. B. WELLES (*Proc. Am. Phil. Ass.* 67, 1936, 7) describes *A Yale fragment of the Acts of Appian*, and takes occasion to give an account of the 'acts of the heathen martyrs' in general. In *Ann. Serv.* 36 (nominally 1936), 115, O. GUÉRAUD and CH. KUENTZ clear away an old misconception. There is a terracotta in the Cairo Mus. which professes to be, and perhaps is, a genuine antique; it represents Harpokrates and has a brief inscr. in hierogl., which has been read as transliterated Gk., *ΧΕΡΝΙΒΟΙΙΑΣΤΗΣ*. They point out that this unheard-of title of the god is a phantom, for in the first place the inscr. is a modern forgery, in the second it consists of three Egn. words mechanically copied from a genuine document. STERLING DOW, dealing with *Egyptian Cults at Athens* in *Harv. Theol. Rev.* 35, 183, uses little or no papyrological material, but his subject-matter is much to the point. S. EITREM (*Symb. Oslo.* 17, 26) prints a paper which he read before the Papyrological Congress at Oxford in 1937 on *Σπονδή, θαλλός and other extra payments*, and uses, but does not confine himself to, papp. for his material. Under the heading *Varia* (*ibid.* 103) he has several points of interest. M. S. SALEM, in *JRS* 27, 165, holds that the so-called Lychnapsia Philocaliana are identical in date with the fourth epagomenal day of the native Egn. calendar; a little of his material comes from papp.

C. RULER-CULT

It happens that, so far as the present writer has noticed, unusually little has been written on this subject. Mention, however, may be made of M. E. HIRST's discussion, in *Cl. Quart.* 32 (1938), 5, of the portents in Horace's second ode and of F. PRÉHAC's brief n. in *Rev. ét. lat.* 15, 273, concerning the position of the colossus of Nero.

D. JUDAISM

I do not attempt as yet to deal with *Princeton University Studies in Papyrology No. 3* (Princeton Univ. Press, 1938), in which A. C. JOHNSON, H. S. GEHMAN, and E. H. KASE edit and comment upon the Scheide Biblical papp. The important new pap. of Ezekiel which it contains and the conclusions drawn therefrom have not yet been long enough before the public for any sufficient body of critical opinion on them to be formed. The Greek OT is well represented in the recent publms. of the Chester Beatty papp., Fasc. IV Sup. (collotypes of the text of Genesis printed in Fasc. IV) and Fasc. VII (Ezekiel, Daniel, and Esther, Papp. IX and X). Both are edited by SIR F. G. KENYON and publ., like the rest of the series, by Emery Walker, London, 1936 and 1937 respectively. The new papp. are the remnants of 118 leaves (236 pp.) whereof there survive in all 89. The most interesting is the Ezekiel (part of the same MS. as the Scheide leaves), which is the LXX version, hitherto represented only by one MS., Chigi R. vii. 45, and a Syriac transl., the rest of the tradition giving the version of Theodotion. The Chigi MS. is shown by the new discovery to be pretty accurate. A summary of much new material is given by H. I. BELL, *Recent Discoveries of Biblical Papyri* (Oxford), appreciatively revd. by H. A. SANDERS, *Am. Journ. Phil.* 58, 370. The fragment of the

LXX, P. Ryl. Gk. 458 (*JEA* 23, 86), is dealt with by H. G. OPITZ and H. H. SCHRAEDER in *Z. f. neut. Wiss.* 35 (1936), 115, who point out that it contains at least one good and old reading, ἐπελάθης (the technical Ptol. word for 'trespass') for the vulg. εἰελάθης in Deut. 23, 35. An old pap. fragm. of the Hebrew Bible has recently been shown to be even older than was formerly supposed. In 1903 S. A. COOK publ. what is known as P. Nash, containing among other things the Decalogue, and tentatively dated it in the early second cent. A.D. W. F. ALBRIGHT (*J. Bibl. Lit.* 56, 145) argues on the basis of material since discovered that the forms of the letters indicate rather a date between 165 and 37 B.C. One very natural result of the accumulation of new material is that no edn. of the Greek Bible can claim anything like finality for its text. H. VON SODEN, reviewing among other things RAHLFS's LXX, LEGG's Mark, and several works on papp. and other MSS. in *Gnomon* 13, 43, writes what is practically an authoritative essay on the present condition of the study and its problems. A much shorter rev. shows the same tendency to consider principles as well as the merits of particular works, A. ALLGEIER's not. of the Göttingen edn. of Mac. 1, in *DLZ* 58, 359. Some criticisms and suggestions accompany the account of P. Chester Beatty IV, V, and ROBERTS, *Two Biblical Papyri* (see *JEA* 23, 86, 87), by 'M.-L.D.' in *Rev. bibl.* 46, 141. The most convenient summary of our information up to the time of writing is that contained in Sir F. G. KENYON, *The Text of the Greek Bible* (London, Duckworth). It is for students, not for the general reader, technical and compressed but admirably clear; relevant matter concerning the NT is of course included. Apart from Biblical texts, some interesting work on Jewish religious hist. has appeared. E. BIKERMAN in *Rev. hist. rel.* 115, 163 is of opinion that the documents in Josephus, *Ant.* 12, 5/258-64 relative to the persecution under Antiochos Epiphanes are either genuine or at least a contemporary forgery; he bases his conclusion on material partly from papp., and has some interesting remarks on ancient documentary forgeries in general. The views of GOODENOUGH (*JEA* 22, 63) on mysteries in Philo have met with some sharp criticism, as that of E. BRÉHIER in *Rev. ét. gr.* 50, 168, and of M. J. LAGRANGE in *Rev. bibl.* 45 (1936), 265, the latter being not wholly free from *odium theologicum*. GOODENOUGH replies in *Quantulacumque* (cf. A above), 227, to his critics, but though his title promises an account of *Literal Mystery in Hellenistic Judaism* he seems to the present writer to use both substantive and adjective in most unusual senses. He breaks new ground in *J. Bibl. Lit.* 56, 103, with an account of the pictorial symbolism which the Jews of that age indulged in despite all precept to the contrary, and gives a most interesting account of its motifs and their relation to Christian art. *Ibid.*, 91, R. H. PFEIFFER collects what is known of the contacts and mutual knowledge of Jews and Greeks before Alexander.

E. MAGIC

The only work of any importance I have noticed is a very good one, HERBERT SCHOLZ, *Der Hund in d. griechisch-römischen Magie u. Religion* (Berlin, Trilitsch & Huther), which draws freely on the magical papp. It is a useful assemblage of facts. A theme partly magical is discussed in *Quantulacumque* (cf. A), 1 by CAMPBELL BONNER, who treats of the Sibyl hanging in a bottle (Petronius, *Sat.* 48).

F. HERMETISM: ASTROLOGY

An important piece of Hermetic exegesis is the art. by A. J. FESTUGIÈRE in *Harv. Theol. Rev.* 31 (1938), 1. He expounds the image of the *krater* in *corp. Herm.* 4, and deduces from it a connexion between Hermetism and the Gnostic circles which produced the Pistis Sophia and the second Book of Jeû; he then treats of the fate of the voluntarily childless in *corp. Herm.* 2, 17. A reviewer ('V.') of SCOTT-FERGUSON, *Hermetica*, IV (cf. *JEA* 23, 86), in *Rev. bibl.* 46, 133, warmly supports FERGUSON where he differs from SCOTT. In *Phil. Woch.* 57, 235, A. SCHERER warmly welcomes GUNDEL's *Neue astrologische Texte* (*JEA* 23, 87), adding some comments and minor corrections. The same work seems to have been the chief stimulus which moved F. CUMONT to compose a really admirable volume, *L'Égypte des astrologues* (Brussels, Fondation Reine Élisabeth), in which he at one and the same time demonstrates the proposition that the existing works on astrology, even the latest, reproduce in substance fairly early Ptol. handbooks and gives a fascinating account of sociological conditions in Eg. before Actium. In *JEA* 22 (1936), 218, R. W. SLOLEY, in reviewing CURTIS-ROBBINS, *An Ephemeris of 467 A.D.* (Univ. of Michigan Press, 1935), points out that it is valuably supplemented and corrected by J. K. FOTHERINGHAM's n. in *Cl. Rev.* 49 (1935), 242, and adds an observation made privately to him by FOTHERINGHAM.

G. NEW TESTAMENT

Besides the admirable work of KENYON, noticed under (D) and warmly welcomed by P. BENOIT in *Rev. bibl.* 46, 604, mention must be made of an excellent manual less strictly specialist, indeed so simple

and clear as to be available for beginners in NT criticism, yet containing matter enough to make it worth the attention of advanced students of the subject. This is K. and S. LAKE, *An Introduction to the New Testament* (London, Christophers, 1938). The authors have most wisely included a sketch of the social, religious, and political conditions of the age in which the events recorded in the NT took place. The only fault I have noticed is a certain looseness of citation in the nn., e.g., 'see Mommsen's *Strafrecht*' (no p. given). The important documents notd. in *JEA* 23, 87, continue to be discussed. M. DIBELIUS in *DLZ* 58, 4, emphasizes the importance of the fragm. of the Fourth Gospel for the confutation of certain extremist views. H. A. SANDERS in *Cl. Phil.* 32, 163, holds that the Unknown Gospel was not put together from the canonical evangels, but 'the author lived in a community where the primitive forms of two gospels circulated, or even where the traditions that preceded such gospels were known'. P. BENOIT, *Rev. bibl.* 46, 58, makes an elaborate examination of the Beatty-Michigan codex of the Pauline corpus, and concludes that on the whole it shows an Alexandrian text like that of B already in existence. E. H. KASE, in a rev. of *Michigan Papyri*, vol. III, in *Am. Hist. Rev.* 43 (1938), 437-8, takes occasion to suggest that the mysterious 'Sceva' of *Acts* 19, 14 owes his existence to nothing more than a dittography of the letters (ἐν οἷ)ς καὶ νιόι, whereof P. Mich. 138 preserves traces in its reading σκενίου. The Beatty-Michigan codex itself is made still further available by the appearance of Fasc. III sup. of *The Chester Beatty Biblical Papyri* (London), with colotypes and a few small corrections of the printed edn. Of the arts. in *Quantulacumque* (see A) several deal with NT criticism from various points of view. Perhaps the most radical is that of H. PERNOT, 173, who holds that the text of the great uncials, and presumably that of all papp. hitherto discovered, is very bad, so far as the Gospels are concerned, owing to extensive early editing and harmonizing. Criticism of sources and historicity of the Gospels, largely under the influence of *Formgeschichte*, comes from H. J. CADBURY (99), R. P. CASEY (109), M. S. ENSLIN (117) and N. HUFFMAN (123). Documents of various extent are produced by H. A. SANDERS (*A Third Century Pap. of Matthew and Acts*, 151) and C. H. KRAELING (*Two Selections from Acts*, 151), and others already known are commented on by SIR F. G. KENYON (145) and CANON STREETER (149). The other arts. on biblical MSS. in this volume do not deal with papp., or not primarily with them.

H. CHRISTIANITY AND CHRISTIAN HERESIES

A further document bearing on Christian interest in chronology is publ. by H. LIETZMANN in *Quantulacumque* (see A), 339. Berlin possesses 'unter Nr. 13296 ein stark zerstörtes und nur auf einer Seite lesbares Pergamentblatt' which on investigation proves to be a fragm. of a chronicle, of the kind which MOMMSEN calls *consularia Constantinopolitana* with its derivative the *consularia Italica*. It runs, with gaps, from 251 to 338, and notes, besides the consuls, the outstanding events of ecclesiastical hist., such as the martyrdom of S. Cyprian and the bringing to Constantinople of the relics of SS. Andrew and Luke. An obscure theological controversy is discussed *ibid.*, 41, by H. G. OPITZ in his essay *Dionys v. Alexandrien u. die Libyer*.

The edn. of the *Πράξεις Παύλου* by C. SCHMIDT and W. SCHUBART (Glückstadt and Hamburg, 1936) has been received with warm praise. H. I. BELL (*JTS* 38, 189) agrees with the editors that the author did no more than let his imagination play on the data of *Acts*. He makes a few corrections and suggestions on small points. H. A. SANDERS, whose rev., in *Cl. Weekly* 30, 141, confines itself to summarizing the work, makes a more important contribution in *Harv. Theol. Rev.* 31, 74, by producing from the papp. of the University of Michigan a part of one of the leaves of the Berlin MS. used by the German editors.

3. Publications of Non-Literary Texts

A. GENERAL

The past year has seen a remarkable extension of our knowledge regarding taxation in Roman Eg., appropriately crowned by the appearance, as this Bibliography goes to press, of the fundamental study of Prof. SHERMAN LEROY WALLACE, *Taxation in Roman Eg.* (Oxford, 1938), comment on which must be deferred till next year.

Pride of place naturally falls to *Tax Rolls from Karanis: Part I, Text* (= *Michigan Papyri*, vol. IV, part I), ed. HERBERT CHAYYIM YOUTIE, with the collaboration of V. B. SCHUMAN and O. M. PEARL. (= *Univ. of Michigan Studies, Humanistic Series*, vol. XLII), xvi + 437 pp., 4 pls., Univ. of Michigan Press, Ann Arbor, 1936, \$5.00. To give an adequate account of this work, which arrived just too late to be noticed last year, is at the moment impossible, since introduction, nn., comm., and indices are all being held over for Part II. Suffice it to say that it publs. three colossal rolls, P. Mich. 223 (now in Cairo), 224 (with republ. of an isolated fragm. already edited as P. Jand. 141), and 225. Together they give us a complete record, in the form

of a day-book, of all money taxes collected in the village of Karanis throughout three entire years (A.D. 171–4). Not only are such general imposts as *λαογραφία*, *φυλάκων*, *χωματικόν*, *τρίτη βαλανείου*, etc., represented, but also many particular dues levied on land or connected with its ownership, such as the *ναύβιον*, *ἀριθμητικὸν κατοίκων*, and a host of others. For a full analysis we must wait for Part II, but meanwhile the editor himself, in *Cl. Weekly* 30, 199–201, has given a valuable general account of the book, including some of the interesting results derived from study of the texts (e.g. that the guard-tax, *φυλάκων*, was payable only by those exempted from *λαογραφία* or unfit for guard-duties). The mass of material is staggering, the three papp. containing over 13,450 lines—‘a text longer than the *Odyssey* and nearly as long as the *Iliad*’—and quite apart from their immediate value for the understanding of the taxation system they form a vast storehouse of raw material for sociological inquiry in many directions. But for the moment we must content ourselves with admiration for the indefatigable labours of the editor and his assistants, and for the skill and clarity with which their work is presented. Revs. so far are mostly non-committal, pending the arrival of Part II; note, however, those by WILCKEN, *Archiv* 12, 241–2, and C. PRÉAUX, *Chron. d'Ég.* 12, 279–81.

Less imposing in size, but hardly of less importance, is the new BGU IX: HEINZ KORTENBEUTEL, *Steuerlisten römischer Zeit aus Theadelphia (Äg. Urk. aus d. staatl. Mus. zu Berlin: Gr. Urk., IX. Bd.), ix* + 268 pp., 4 pls., Berlin, 1937. The texts here run to a mere 2,968 lines—‘wie eine freundliche Villa neben einem amerikanischen Wolkenkratzer’, as WILCKEN humorously observes. The contents are, however, much more diverse than those of P. Mich. IV, and the hist. of the papp. themselves needs some explanation. BGU 1891–9 are derived from a group of 7 rolls acquired by the Berlin Mus. in 1912. The verso of one of these has already been publ. (the famous *Gnomon* of the Idios Logos), the recto of another has been edited under the title *Bankakten aus d. Faijum*, by H. FRISK; the present work publs. recto and verso of three more rolls and the recto of the *Gnomon*, thus leaving two rolls and the verso of the *Bankakten* still to be edited. BGU 1900 was acquired by exchange from the BM in 1913. From the same find come the rolls at Columbia Univ. publ. by WESTERMANN and KEYES in *Tax Lists and Transportation Receipts from Theadelphia*.

A very brief indication of the contents may be given here: 1891–2 are day-books of the *πράκτορες ἀγγυρικῶν* of Theadelphia, recording payments for *λαογραφία* and associated taxes (A.D. 134); 1893 (on recto of the *Gnomon*) is a list of payments in kind received by the sitologi of *Βερνικίς Αἰγιαλοῦ* (A.D. 149); 1894, totals of all money-taxes received in Theadelphia in A.D. 157, arranged under heads—a most important document recording many new taxes, though its value is somewhat marred by lack of a logical disposition; 1895, receipts of taxes in kind, Theadelphia, A.D. 157; 1896, assessments of various garden- and vineyard-taxes, under names of land-holders, A.D. 166 (?); 1897, alphabetized register of payers of *οκτάδραχος σπονδὴ Διονύσου* and *δωδεκάδραχος*, A.D. 166; 1897 a, arrears of *ναύβιον κατοίκων* and *ναύβιον ἐναφείων*, A.D. 166; 1898, alphabetized list of payers of an unspecified land(?) tax, A.D. 172; 1899, similar to 1896, A.D. 172; 1900, list of 50 associations for collective farming of land, c. A.D. 196. Since each holding is almost exactly 80 arouras, the total area of land involved is $80 \times 50 = 4,000$ arouras. It would hardly have been possible to divide up land already under cultivation in this way, and it looks as though we have here some large-scale attempt to reclaim waste lands.

The editing of these texts, bearing in mind the restrictions imposed by the general plan of the BGU, is beyond all praise. The introductions are crisp and clear, the comm. succinct and sober; as is fitting in an edn. of what will be primary documents for the hist. of taxation, the editor has shown a commendable reluctance to indulge in theorizing, and is never afraid to record a *non liquet*. A good popular account of the book is given by KORTENBEUTEL in *Forsch. u. Fortschr.* 13, 314–15, concluding with the announcement that BGU X will contain a further instalment of the Augustan papp. from Abušir el-Meleḡ, BGU XI Byzantine papp. from the German excavations at Hermopolis. BGU IX is revd. by WILCKEN in *Archiv* 12, 239–41.

The small collection of papp. owned by the Fondation Égyptol. Reine Élisabeth, Brussels, consisting of some 150 pieces ranging in date from the third cent. B.C. to the seventh A.D., is being publ. *seriatim* in *Chron. d'Ég.* by M. HOMBERT and C. PRÉAUX. The first document selected for editing is a third-cent. private letter in very vulgar Gk., which provides plenty of problems both of reading and interpretation; *Chron. d'Ég.* 12, 92–100, with pl. Revd. by WILCKEN in *Archiv* 12, 242–3. More interesting is the second item (*Chron. d'Ég.* 12, 258–64, with pl.), a note (A.D. 91–2) certifying that one Satabous has been exempted from poll-tax as *ἀσθενής*, which the editors interpret as physical rather than economic disability.

P. Mich. III (*JEA* 23, 88–9) has been revd. by WILCKEN in *Archiv* 12, 228–31; C. B. WELLES, *AJA* 41, 509–10 (important suggestions); C. PRÉAUX, *Chron. d'Ég.* 12, 269–70; K. FR. W. SCHMIDT, *GGA* 199, 147–56 (very long and detailed); H. I. BELL, *JTS* 38, 417–18. F. HEICHELHEIM, *Zu Pap. Mich. III 173 u. Hesperia V (1936), 419 ff. Nr. 15*, in *Aeg.* 17, 61–4, points out that the ratio of silver to copper implied in the

document in question is very much *lower* than 1:325, hence it cannot be assigned to the reign of Philometor (cf. *JEA* 23, 89). HEICHELHEIM's argument would seem to be confirmed by the independent observation of WELLES, in the above-mentioned rev., that P. Mich. 182 (182 B.C.) already implies a ratio of 1:432. But the whole question is very involved, and I do not think the last word has yet been said.

P. Oslo. III (*JEA* 23, 89–90) has been revd. by WILCKEN in *Archiv* 12, 225–8; in a characteristically brilliant n. on the 'nomarch of Naukratis' mentioned in P. Oslo. he observes that the only other instance of government by a nomarch is the likewise autonomous Gk. city of Antinoopolis. The territory (*νομαρχία*) of Antinoopolis was never an independent nome, but an enclave in the Hermopolite nome (cf. *JEA* 21, 84), and so, probably, there was a Naukratite *νομαρχία* in the Saïte nome. The parallelism of these institutions is simply explained by the fact that Hadrian took Naukratis as the model for his new foundation of Antinoopolis. C. B. WELLES, in *AJA* 41, 510–12, has some important suggestions to make, especially on P. Oslo. 118, 130, 133, and 140, while F. ZUCKER, *Zu Papp. Oslo. III* in *Symb. Oslo.* 17, 54–6, prints some miscellaneous nn. on the documentary papp. P. HEEGAARD, *Three Horoscopes in the Oslo Collection*, *Symb. Oslo.* 15–16, 98–100, discusses P. Oslo. 163–5, of which only the bare texts are printed in P. Oslo. III. S. EITREM's paper, *Religious Calendar concerning the Imperial Cult in Atti IV Congr. Int. Pap.*, 85–8, is now superseded by the final publ. of the pap. as P. Oslo. 77.

P. Harris (*JEA* 23, 89) has been revd. by WILCKEN in *Archiv* 12, 234–6; B. SNELL, *Gnomon* 13, 577–86 (almost entirely on literary texts); C. PRÉAUX, *Chron. d'Ég.* 12, 270–4; W. G. WADDELL, *Cl. Rev.* 51, 70. G. GHEDINI contributes *Note a tre lettere cristiane in P. Har. to Aeg.* 17, 98–100, discussing P. Harris 107, 126, and 158.

P. Varsov. (*JEA* 22, 68) is severely criticized by K. FR. W. SCHMIDT in *Phil. Woch.* 57, 1003–9; many suggestions for new readings are made.

P. Janda VI (*JEA* 21, 84) and VII (*ibid.*) are very favourably revd. by P. VIERECK in *Hist. Z.* 153 (1936), 569–71, and 156, 335–8. The latter vol. is the subject of an extremely able and detailed not. by E. KIESSLING in *Gnomon* 13, 98–103, making some indispensable corrections in P. Jand. 137 (τῶν μ(ῆ) ἐν[γ]εγραμ[μέν(ων)]) in l. 17, and [μῆ ἐγγε]γραμ(μ)ένων in l. 20). Other revs. of P. Janda VII come from H. KORTENBEUTEL, *Riv. di fil.* 15, 215–17, and K. FR. W. SCHMIDT, *Phil. Woch.* 57, 128–31.

To turn to publ. of ostr., O. Wilb.-Brk. (*JEA* 22, 67–8) is notd. by H. I. BELL, *JEA* 23, 135–7 (detailed criticism of Mlle PRÉAUX's views on the institution of *λαογραφία*, which the reviewer finds unconvincing); M. ENGERS, *Museum* 44, 133–5 (some criticisms; thinks the editor too ready to generalize from insufficient material); N. LEWIS, *Cl. Weekly* 30, 95; W. SESTON, *Rev. ét. anc.* 38 (1936), 465–6 (important on meaning of *merismos* and possible relation to the *caput*); CH. PICARD, *J. Sav.*, 1937, 182–3; W. PEREMANS, *Rev. belge* 15 (1936), 1055–9 (in Flemish, but might be important to those who can read it); M. SEGRÉ's rev. in *Il Mondo classico* 6 (1936), 372 I have not seen.

O. Mich. (*JEA* 22, 68) has been revd. by N. LEWIS, *Am. Journ. Phil.* 58, 105–7; O. Oslo. (*JEA* 20, 88) by F. ZUCKER in *Gnomon* 12 (1936), 668–9 (some good suggestions).

Finally G. MANTEUFFEL, *Die neue Warschauer Ostrakasammlung, Atti IV Congr. Int. Pap.*, 45–50, gives some facts about 121 ostr. bought from the collection of Prof. A. DEISSMANN; these are different from the Deissmann ostr. already publ. by P. M. MEYER in his *Gr. Texte aus Äg.*, which are now in the Univ. of Sydney, N.S.W. MANTEUFFEL appends a publ. of three ostr. of the Roman period, but even if the reading of the texts is to be relied upon, I find it impossible to believe in the expansions of the abbreviations proposed. It is to be hoped that the definitive publ. will include plenty of good facsimiles.

GOODSPEED and COLWELL's *Gk. Papyrus Reader* (*JEA* 22, 68) is revd. by C. W. KEYES, *Cl. Journ.* 32 (1936–7), 303–4; E. P. WEGENER, *Museum* 44 (1936–7), 164–5 (rather critical); and V. B. SCHUMAN, *Cl. Phil.* 32, 380–2 (important corrections, made from inspection of the original, to P. Goodsp. 3, republ. as No. 70 of the present collection).

B. PTOLEMAIC

Another fascicule of UPZ has appeared: U. WILCKEN, *Urk. d. Ptolemäerzeit (Ältere Funde)*, II. Bd.: *Papp. aus Oberäg.*, 2. Lief., pp. 91–213, Berlin & Leipzig. The steady rate at which this monumental undertaking proceeds, and the clear and easy style of presentation, make one apt to forget the incalculable labour involved, each *Lieferung* in itself being almost equal in extent to an average-sized vol. of papyri. One special feature of this part is the help given by SIR HERBERT THOMPSON in supplying information about the relevant dem. documents, and the collaboration of the two acknowledged masters of Gk. and dem. papyrology respectively is a matter for special rejoicing.

The contents may be briefly indicated here: Nos. 163-9 are bankers' dockets to dem. contracts relating to the famous house around which the law-suit of Hermias centres; 170-3 are the papers of Apollonios *alias* Psemmonthes, which, WILCKEN claims, have no connexion with the Hermias archive; 174-84 are contracts of sale between members of the choachytae, separated for the sake of clarity from the Hermias papp., and including the celebrated 'Casati contract' (No. 180), which with its appropriate comm. runs to 28 pp. of text; 185-90 are miscellaneous papp. relating to the choachytae; 191-3 are the petitions of the pastophori of Amenophis to the Epistrategus Phommous; 194-7 are docs. of the paraschistae. This leaves only the records of the royal bank at Thebes still to be edited, with the indices to the entire work.

A remarkable pap. in the Rainer collection has been edited by H. LIEBESNY, *Ein Erlass d. Königs Ptolemaios II Philadelphos über d. Deklaration von Vieh u. Sklaven in Syrien u. Phönikien* (PER Inv. Nr. 24. 552 gr.), in *Aeg.* 16 (1936), 257-91. It contains, in fact, two separate proclamations made by Philadelphus in 262-1 B.C. to his Palestinian dominions, the former establishing an annual registration of cattle (*λεία*), the latter, and more important, a registration within 20 days by all who had either bought or taken in pledge persons characterized as *σώματα λαϊκά ἐλεύθερα*, and a general prohibition for the future of this scarcely-disguised form of slavery, expressly excepting, however, soldiers and 'others domiciled (*κατοικοῦντες*) in Syria and Palestine' living with native women (*cf.* the Syrian Elaphion of P. Eleph. 3-4). WILCKEN, reviewing the publ. in *Archiv* 12, 221-3, points out the remarkable parallels between it and the famous alleged decree of Philadelphus which is incorporated in the Letter of Aristeeas, and which he regards as a genuine document. At the last moment a full discussion of the second proclamation comes from the pen of the acknowledged authority on problems of slavery, W. L. WESTERMANN, *Enslaved Persons who are free*, *Am. Journ. Phil.* 59 (1938), 1-30. Among a number of attractive and important suggestions may be noted his theory that the present proclamation was designed to close loop-holes in an earlier one ordering a general registration of slaves in Syria and Phoenicia, parallel to P. Hib. 29. WESTERMANN strongly holds that the Aristeeas *πρόσταγμα* is spurious.

Three papp. from the Zenon archive in Athens are publ. by S. B. KOUGEAS in *ΕΛΛΗΝΙΚΑ* 9 (1936), 5-16, with good photos., which are all the more valuable as the originals of the first two papp. have been mislaid in the Historical Seminar of the University. The third is in the Archaeological Museum. No. 1 is a letter of Apollonios the Dioketes to Zenon ordering him to take delivery of and transport by canal to Philadelphia a cargo of wood sent through Nikeratos, a copy of a letter to whom is subjoined. The letter belongs to a period when Apollonios was taking an active interest in the development of his *δωρεά*, and another letter from him, P. Cair. Zen. 59221, is actually dated the same day (Dec. 19, 254). No. 2, a fragment of a letter to Apollonios, seems to offer terms for building or repairing irrigation works, apparently on a large scale, for even if the figure 15,000 in l. 4 is not to be taken with the immediately preceding *σώμασιν*, 5,000 mattocks are certainly referred to in l. 5. No. 3, dated Oct. 25, 251, has had a curious history; originally it was a letter from Zenon to Kleitarchos, sharply reprimanding him for having omitted from his account various items, one of over 9,000 artabs of barley; after it was sealed and addressed, Zenon decided to alter the wording, so the letter was unfolded and the text drastically remodelled. Having now become a draft, it was of course retained in Zenon's office.

H. KORTENBEUTEL, *Zum Sondergericht d. Aposkeuai*, *Aeg.* 16 (1936), 292-5, publ. an application, of the second cent. B.C., from a woman describing herself as 'the *ἀποσκευή* [a term for wives and children of soldiers on active service] of Zeuxilas'; the application is addressed to a phourarch, and KORTENBEUTEL concludes that it was this officer who was entrusted with the special jurisdiction which we know the *ἀποσκευαί* enjoyed. WILCKEN in his rev., *Archiv* 12, 223-4, emphasizes how much we still have to learn about this obscure institution.

Some skilful restorations in the well-known letter announcing the approaching visit of a Roman senator are proposed by A. WILHELM, *Pap. Tebtunis* 33, in *JRS* 27, 145-51.

P. JOUQUET, *Quittance de prêt en forme de contrat à six témoins datant de l'an 7 de Ptolémée Aulète*, *Mél. Desrousseaux*, 229-38, I have not yet been able to see. From the Brussels cards I learn that it is a pap. belonging to the French Institute in Cairo, and written at Ibiou Eikosipentarouron in the Fayyūm, Dec. 18, 75 B.C.

NOCK, ROBERTS, and SKEAT, *The Gild of Zeus Hypsistos* (*JEA* 23, 91), has been revd. by WILCKEN, *Archiv* 12, 219-21. For the troublesome verb in l. 13 WILCKEN proposes *συνπ(ν)ευματαρχήσειν*, 'to head a conspiracy', which is certainly attractive. I may add that I now read *τ[ό]σον ἐκ τόπ(ου)* in l. 19, for which expression *cf.* P. Ryl. 67, 5, and P. Lond. inv. 2327 (unpubld.); after this I am inclined to think *ἀποκλέψειν τ[ή]ν ἐτεραν* (= *ἐταίραν*) the simplest, if a somewhat sensational, solution.

C. ROMAN

A. E. R. BOAK, *An Ordinance of the Salt Merchants*, *Am. Journ. Phil.* 58, 210–19, publ. a Michigan pap. containing an agreement made by an association of ἀλοπῶλαι at Tebtunis in A.D. 47. This throws a flood of light on the working of the salt monopoly under the Romans; in language resembling the statute of an ordinary σύνοδος, the association decides who shall collect the trade-tax, which of the various members shall sell salt or gypsum, or both, and where, and at what price; the complete absence of any ref. to Government control is particularly significant. Revd. by C. PRÉAUX, *Chron. d'Ég.* 12, 281–3.

PHILLIP H. DE LACY, *An Oxyrhynchus Document acknowledging repayment of a loan*, *JEA* 23, 76–80, with Pl. xi, publ. a Princeton pap. dated June 14, 52. Especially valuable is his complete list (in the nn., on pp. 78–9) of ἡμέραι Σεβασταί, quoting 46 passages as against 24 in BLUMENTHAL's earlier collection.

Two Latin tablets recording the births of children to soldiers on active service (who being prohibited from contracting legal marriages could not get their children officially registered in the ordinary way) have recently been publ.; the earlier, dated April 25, 127, is edited by H. I. BELL, *A Latin Registration of Birth*, in *JRS* 27, 30–6, and Pl. ii. Though comprising only the second half of a diptych, the writing is fortunately so disposed that the beginning of the *scriptura exterior* and the ending of the *scriptura interior* are both preserved, giving between them an almost complete text. The second tablet is publ. by H. A. SANDERS, *A Birth Certificate of 138 A.D.*, in *Aeg.* 17, 233–40, with illusts. Here only the second half of the document is preserved, the texts on the wood and on the wax being practically identical; luckily, however, both preserve the references to the *lex Aelia Sentia et Papia Poppaea* which regulated the procedure here adopted.

W. G. WADDELL, *A Numbered Petition among the Papp. Fuad*, *Atti IV Congr. Int. Pap.*, 61–2, is interesting for the method adopted for the registration of petitions. The doc. is a petition to the Prefect M. Sempronius Liberalis (c. A.D. 157–9).

Perhaps the most surprising addition to our knowledge of Roman Eg. is the Rylands pap. publ. by ERIC G. TURNER, *The Gerousia of Oxyrhynchus*, *Archiv* 12, 179–86. This is an application, dated A.D. 226, by a citizen of Oxyrhynchus to a municipal official described as διέπων τὰ στέμματα, demanding enrolment in οἱ ἀπὸ τοῦ γεροσίου on the ground that he has reached the prescribed age of 68. To prove this he subjoins an extract from the πεδιακὸν ἐπικρίσεως, the cataster compiled from the κατ' οἰκίαν ἀπογραφαί the nature of which was finally established by WILCKEN's researches last year (cf. *JEA* 23, 92). TURNER discusses the instances of a gerousia in other parts of the Roman world, but decides that the gerousia of Oxyrhynchus was not a parallel institution; it was purely an age-group, of limited numbers, and the members had no political power, though they might possess considerable social influence—'like an Old Boys' club'. Another ref. to the gerousia of Oxyrhynchus can now be found in the hitherto puzzling doc. publ. by G. POGGI in *Aeg.* 15, 209; TURNER points out that [γε]ρόντων in A. 29 and [γερόν]των in B. 30 can be restored with practical certainty. The Rylands pap. will be republ. in P. Ryl. IV.

Hardly less surprising is the appearance of one of the lost columns of the *Acta Appiani* (P. Oxy. 33, now P. Lond. Inv. 2435 verso); it immediately precedes the already publ. text, and gives some further sensational, if rather baffling details of this *cause célèbre*. Now in the library of Yale University (Inv. 1536), it is excellently publ. by C. B. WELLES, *A Yale Fragment of the Acts of Appian*, *TAPA* 67 (1936), 7–23, with a photo. and an interesting general discussion of docs. of this class.

O. GUÉRAUD, *Un Édît du Préfet T. Haterius Nepos au sujet du bas clergé égyptien*, *Mél. Desrousseaux*, 199–209, and P. ROUSSEL, *Remarques sur un pap. florentin*, *op. cit.*, 429–34, are not at the moment accessible.

HENRI JANNE, *La Lettre de Claude aux Alexandrins et le christianisme*, *Mél. Cumont*, 273–95, discusses the whole question afresh, and comes out strongly for the view that the letter was occasioned by conflicts between Jews and Christian missionaries, pointing out, in addition to the alleged parallels in Acts (which he accepts) that the Church of Alexandria was traditionally founded in A.D. 40.

SKEAT and WEGENER, P. Lond. 2565 (*JEA* 23, 91–2), is revd. by C. PRÉAUX, *Chron. d'Ég.* 12, 106–9 (important on the conflict of principles revealed by the speeches at the trial).

In *Archiv* 12, 238–9 WILCKEN records some *addenda* and *corrigenda* to his edn. of P. Brem. (*JEA* 23, 91), which with characteristic modesty he refuses to review, except for a bare outline of the contents.

W. H. BUCKLER, *Epistula Traiani. Rectification*, *Rev. de phil.* 11, 404, publ. a correction by ARTHUR STEIN to BGU 140. Lines 3–4 should be restored [L]ῆ Τραι[α]νοῦ Ἀδριανοῦ Σεβαστοῦ [καὶ] | [[Που]πλίου 4[ασσουμίου 'Ρου]στικού; the emperor is thus Hadrian, not Trajan, and the date 119.

D. ROMAN-BYZANTINE

P. COLLOMP and his pupils continue their publ. of the Strasbourg collection (cf. *JEA* 23, 90) by editing,

with the briefest of nn., six more docs., ranging in date from 277 to 391 A.D.: *Papyrus grecs de la Bibliothèque nationale et universitaire de Strasbourg* (suite), *Bull. de la Faculté des Lettres de Strasbourg*, 15, 173–6, 229–32.

E. P. WEGENER, *Four Papyri of the Bodleian Library* (*JEA* 23, 93), is revd. by WILCKEN, *Archiv* 12, 246. P. Ross.-Georg. v (*JEA* 23, 93) is revd. by M. SAN NICOLÒ in *DLZ* 58, 851–2.

E. BYZANTINE

C. PRÉAUX, *Une Reconnaissance de Dette du IV^e siècle après J.-C.* (P. Wilbour Brooklyn gr. 1), *Arch. hist. dr. or.* 1, 1–16, Pl. iii, publ. a pap. in the Brooklyn Mus. Though containing little to excite special interest (it is a loan without interest of 20 artabs of corn), the doc. is subjected to a detailed analysis, clause by clause, which is a model of lucid exposition. W. KAMPS contributes, in an appendix, a juristic analysis and a list of the legal terms employed.

A fine and unusual doc. is publ. by M. NORSA, *Elezione del ΚΕΦΑΛΑΙΩΤΗΣ di una Corporazione del V secolo D.C.*, *Ann. R. Sc. Pisa* 6, 1–7, Pl. i. It consists of a formal notification from the members of a corporation to one Aur. Chaeremon, announcing that they have elected him their *κεφαλαιωτής* for the coming year, enumerating his duties, and various rules for the conduct of members. The business of the corporation is obscure, through mutilation of the pap., but may have been banking; the date is either 426 or 441 A.D.

S. G. KAPSOMENOS, a pupil of SCHUBART, edits two papp. in Berlin under the title *Zwei byzantinische Papyri aus d. Zeit Justinians*, *BZ* 37, 10–17. The former is an order from the Praeses of the Thebaid, Fl. Phoebammon, for payments by the village of Aphrodito towards the annona of a numerus of Numidians stationed at Hermopolis; though only the right half is preserved, the text can be completely restored by the aid of the parallel docs., P. Lond. 1663 and P. Cair. Masp. 67321. The other doc. is a contract of surety on behalf of a private tax-collector on the domains of one Dioscorides, a singularis in the service of the Dux of the Thebaid. It is dated at Antinoopolis, A.D. 538.

A fifth-cent. pap. from the still unpubl. Weill collection is separately edited by Mlle G. ROUILLARD, *ΦΛΙΑΚΟΝ de Fl. Jean, officialis*, in *Mél. Desrousseaux*, 417–22. Described as a *φιλιακόν*, an obscure term which the contents do nothing to elucidate, the doc. is in fact a receipt of 9 sol. *ὑπὲρ τοῦ προστάγματος τῶν χωμάτων* (*l. χωμάτων*) *Τεντύρων*. In spite of Mlle ROUILLARD's efforts, the situation remains far from clear.

A. E. R. BOAK, *Early Byzantine Papyri from the Cairo Museum*, Nos. 8–20 (*JEA* 23, 93–4) is cordially revd. by WILCKEN, *Archiv* 12, 244–6. In his not. of C. H. ROBERTS, *Two Letters of the Byzantine period* (*JEA* 22, 70), WILCKEN (*Archiv* 12, 247) makes some minor corrections in the text from his own revision of the originals.

4. Political History, Biography, Administration, Topography, Chronology

A. GENERAL

M. H. FISCH, *Alexander and the Stoics*, *Am. Journ. Phil.* 58, 59–82, 129–51, examines and rejects the views put forward by W. W. TARN in his British Academy Lecture *Alexander the Great and the Unity of Mankind*, and offers a tentative reconstruction of the hist. connexion between Alexander and the Stoics. CHARLES ALEXANDER ROBINSON, JR. in *Alexander the Great and the Barbarians* (*Classical Studies presented to Edward Capps*, Princeton, 1936, 298–305) associates himself with TARN's views as expressed in the lecture. W. SCHUBART writes a brilliant short survey, *Verfassung u. Verwaltung d. Ptolemäerreiches* (*Alte Or.* 35, Heft 4), and also a short summary of the main characteristics of the Hellenistic king (*Forsch. u. Fortschr.* 13, 123–4). A. HEUSS's *Stadt und Herrscher d. Hellenismus in ihren staats- u. völkerrechtlichen Beziehungen* (*Klio*, Beiheft 39) is a pioneer work in the juridical sphere. In *Un Problème de la politique des Lagides: la faiblesse des édits* (*Atti IV Congr. Int. Pap.*, 183–93) CLAIRE PRÉAUX provides a comm. on the aims of Ptol. domestic policy and the mistaken attempt to use legislation as a means to economic ends. The weaknesses of Ptol. legislation—the contrast of statute and practice, the series of regulations containing the same provisions, the necessity for using violence in execution, the growth of a special official morality, and development of a system of private guarantees—are damningly set out. W. W. TARN's book *Hellenistic Civilisation* has been transld. into French by E. J. LEVY (*La Civilisation hellénistique*, Paris, 1936). The rev. of PAOLA ZANCAN, *Il monarca ellenistico nei suoi elementi federativi* (*JEA* 23, 94) by CLAIRE PRÉAUX (*Chron. d'Ég.* 12, 110–12) should be noted.

In *Das Gesetz u. d. Kaiser in griechischen Urkunden* (*Klio* 30, 54–69) W. SCHUBART, following a similar

method to that used in *Das hellenistische Königsideal* (*JEA* 23, 94), examines the generalizing clauses of documents, especially petitions, to show that while much that is Hellenistic was retained in the ideal portrait of the Roman emperor, one very important difference is the conception of Law as parallel or opposed to the ruler. E. BRECCIA's *Das römische Aegypten* (*Die Antike* 13, 61-76) is a transl. into German of an art. that originally appeared in *Le Vie d'Italia e del mondo* 3 (1935), 1035-63.

B. POLITICAL HISTORY

A. PRIDIK writes on *Berenike, d. Schwester d. Königs Ptolemaios II Evergetes: Untersuchungen zur Ptolemäer- und Seleukidengeschichte*, in *Acta et Commenta Universitatis Tartuensis*, 35-6 (Tartu, 1936), viii+305 pp.

W. OTTO's *Zur Geschichte d. Zeit d. 6. Ptolemäers* (*JEA* 21, 89) (revd. also by C. B. WELLES, *Am. Journ. Phil.* 57 (1936), 349-52) has inspired P. JOUGUET to write a comm. on Egyptian hist. during the period in question, in which he discusses and criticizes a number of OTTO's views (*Les Débuts du règne de Ptolémée Philométor et la sixième guerre syrienne*, *Rev. de phil.* 11, 193-238). H. HENNE, *Note sur le règne conjoint de Philométor, du futur Evergète II et de Cléopâtre II* (*Rev. ét. anc.* 38 (1936), 443-7), calls attention, as others have done (e.g. H. I. BELL and T. C. SKEAT in their review in *JEA* 21, 262-4), to P. Teb. III, 811 and other documents to show that the association of Cleopatra II with Philometor and his brother had certainly taken place by 167/6 B.C. V. ARANGIO-RUIZ, *Una nuova iscrizione sul protettorato dei Tolomei in Cirenaica*, *Riv. di fil.* 15, 266-77, comments in detail on an inscr. publ. in *Documenti antichi dell'Africa italiana* as No. 538. This text (and the whole of it is to be dated to 109/8 B.C.) shows Ptolemy Soter II regulating affairs in Cyrene as if sovereign, though acc. to Justin 39, 3, 1, etc., on the death of Euergetes II in 116 B.C. Cyrene was left as an independent kingdom to the latter's natural son Apion. The style and address of the inscr. do not allow the possibility that Apion was at this period acting as viceroy for Soter II.

In *César et Cléopâtre, Annales de l'École des Hautes Études de Gand*, 1, 37-77, J. CARCOPINO, resuming a point of view taken up in *Pointes de vue sur l'impérialisme romain*, 89-155, establishes a strong case for his thesis that any romantic attachment between Caesar and Cleopatra, whether in Alexandria or Rome, was entirely incidental to Caesar's intention of subordinating Eg. to Roman power. Among other evidence for the successful execution of this intention he offers a new interpretation of the dem. stela from the Serapeum (now Louvre 335), according to which the Caesar whose birthday is celebrated on Payni 23 (REVILLOUT's reading confirmed) is the dictator, and the date is 47 B.C.: the Egn. priesthood received instructions to celebrate simultaneously their own festival of Isis and the *dies natalis* of the master of the Roman world. He further examines the claim (made on grounds of high policy, whatever the rights of the case) that Caesarion was Caesar's child, and attempts to prove it impossible for chronological reasons, but his arguments do not amount to demonstration. L. E. LORD, *The Date of Julius Caesar's Departure from Egypt, Classical Studies presented to Edward Capps*, Princeton, 1936, 223-32, concludes that Caesar must have left Alexandria by May 1, 47 B.C., or very soon after.

U. WILCKEN's paper, *Octavian after the Fall of Alexandria*, *JRS* 27, 138-44, is of considerable interest for Octavian's intentions towards Eg. and his relations with the Senate. WILCKEN shows that in the Bucheum stela No. 13 (29 B.C.) the so-called 'kratesis' era is used, not the dating by regnal years. The priests of Hermonthis, in contrast to those of Philae in the same year, chose the former method since it did not involve the recognition of Octavian as Pharaoh. But opposition from the Egn., perhaps reinforced by the veiled disapproval of the Senate, which encouraged the conqueror to make use of a dating-system not based on regnal years, was swept aside by Octavian's imperiousness. C. B. WELLES's introduction to P. Yale Inv. 1536 (cf. § 3) (*A Yale Fragment of the Acts of Appian*, *TAPA* 67 (1936), 7-23) sketches Roman policy towards Alexandria and the hist. of Alexandrian nationalism.

I have not seen either E. ALBERTINI, *Les troupes d'Afrique et leur prétendu mouvement vers l'Ég. en 308*, *Mél. Maspero* 2, 261-6, or G. BARDY, *La rivalité d'Alexandrie et de Constantinople au V^e siècle*, *France franciscaine* 19, 5-19.

C. BIOGRAPHY

This year's book on Cleopatra is by JACK LINDSAY, *Last Days with Cleopatra*, London, 1936. In *PW*, XIX/I, 1217-19 there is a full prosopographical account by A. STEIN of *M. Petronius Mamertinus*, and an added note by W. HOFMANN. A. STEIN makes some interesting observations in *Papyrusforschung u. Prosopographia Imperii Romani, Atti IV Congr. Int. Pap.*, 209-15.

D. ADMINISTRATION

V. TSCHERIKOWER, *Palestine under the Ptolemies, A Contribution to the Study of the Zenon Papp.*, *Mizraim* 4-5, 9-90, uses the correspondence of Zenon's journey in Palestine in 259-8 B.C. and the letters from agents and sheikhs in the following years to illustrate Ptol. commercial, military, administrative, urban, and land policies in Palestine, and contrasts them with those applied in Eg. Some of the same ground is covered by G. VAGGI, *Siria e Siri nei documenti dell'Egitto greco-romano*, *Aeg.* 17, 29-51, a collection and analysis of instances of the adjective.

H. LIEBESNY's publ. of *Ein Erlass d. Königs Ptolemaios II Philadelphos* (*Aeg.* 16 (1936), 257-91) (*cf.* § 3) adds some information about the administration of Syria and Phoenicia as a Ptol. province. E. KISSLING sketches the present state of knowledge *Zum Katökenproblem in Aegypten in Forsch. u. Fortschr.* 13, 392. F. ZUCKER's careful art. *Πέροαι* in *PW*, XIX, 910-26, while especially concerned with the legal fiction of *Πέροαι τῆς ἐπιγονῆς*, devotes several columns to an examination of the actual antecedents of persons described as *Πέροαι* and *Π.τ.ε.* and their grouping in *πολιτεύματα*. W. PEREMANS, *Vreemdelingen en Egyptenaren in Vroeg-Ptolemaisch Egypte*, Louvain, xxx+313 pp. (in Flemish) contains elaborate lists and statistics of foreigners in early Ptol. Eg. The same author has written what I take to be a summary of part of his results in *Jaarbericht* 4, *Ex Oriente Lux*, 183-6, *Vreemdelingen en Egyptenaren in Egypte gedurende de 3de Eeuwe v.c.*

A. CALDERINI, *Nuovi studi sulle schede di censimento* (*Scritti in onore di Bartolomeo Nogara*, Rome, 45 ff.) reports on recent work done on the Egn. census, and comments on 14 census declarations published since his last collection of evidence (*Aeg.* 12 (1932), 346). In an important paper, *Recensement périodique et réintégration du domicile légal* (*Atti IV Congr. Int. Pap.*, 225-50), V. MARTIN questions the proposition that there was a necessary connexion between the 14-year census and the command, issued to persons living outside their *ἰδία*, to return there, not merely to register, but to remain there subsequently. He revs. the machinery of the census edicts, and offers a new interpretation of the edict of Vibius Maximus. It was addressed solely to Alexandrians, and made it possible for individuals from the nomes whose presence was required in the city to obtain a permit to return there after registering in their homes.

In a rev. of CLAIRE PRÉAUX, *Les Ostraca grecs de la collection Charles-Edwin Wilbour au Musée de Brooklyn* in *JEA* 23, 135-7, H. I. BELL gives reasons for believing in the existence of a form of poll-tax in Ptol. times, and for rejecting the view that payment of poll-tax was a mark of inferiority. In a lecture which I regret being unable to see H. C. YOUTIE summarized the hist. of tax-farms in Athens, Rome, and Eg. (*Publicans and Sinners*, *Michigan Alumnus Quarterly Rev.* 43, 650-62). In *ΜΕΡΙΣΜΟΣ ΑΝΑΚΕΧΩΡΗΚΟΤΩΝ: an Aspect of the Roman Oppression in Egypt* (*JEA* 23, 63-75) N. LEWIS, in addition to discussing the tax in question, provides the fullest collection of evidence to date on the flight from the land in the Roman period. H. HENNE, *Le Démotique ΠΟΛΙΕΥΣ à Antinooupolis* (*Atti IV Congr. Int. Pap.*, 321-31), attempts an explanation of it, and of certain other deme and tribe names of that town.

In *PW*, VI A 2, 2205, art. *Trapeza*, E. ZIEBARTH sketches the hist. of banking in Eg., both as monopoly and as a field for private enterprise, and his art. is supplemented by a note of E. KISSLING's, *op. cit.*, 2208-9 *s.v.* *Trapezites*. E. ZIEBARTH also writes seven lines on one of the more interesting of Alexandrian and Egn. municipal offices in *PW*, XVII/2, 1517, *Nuktostrategos*. To *PW*, XVII/2 W. ENSSLIN contributes the article on *Numerarius*, and *op. cit.*, XIX/1 he discusses the honorary title *Perfectissimus*.

E. TOPOGRAPHY

A. CALDERINI's *Dizionario dei nomi geografici e topografici dell'Egitto greco-romano*, part 1 (*JEA* 22, 71), continues to receive a warm welcome. Some additions and corrections are given by J. SIMON, *Orientalia* 6, 132-42. C. ANTI, *Scavi di Tebtynis (1930-1935)*, *Atti IV Congr. Int. Pap.*, 473-8, makes some remarks about the topography of Tebtunis à propos of the archaeological mission directed by him. Similarly A. VOGLIANO, *Gli Scavi della Missione archeologica Milanese a Tebtynis*, *Atti IV Congr. Int. Pap.*, 485-96, has a few observations about Ibion (Medinet Mādī). M. J. LEIBOVITCH, *A propos de l'expédition militaire dirigée en Éthiopie par P. Petronius sous le règne d'Auguste*, *Bull. Soc. roy. de Géographie d'Ég.* 19, 270-7, in an attempt to fix the locality of *Pathros* of the dem. texts, suggests identifications for the *oppida* captured by Petronius in Nubia (Pliny, *N.H.* vi. 35, 4). In *PW*, XVII/2, 1509, WINDBERG writes notes on the Ethiopian peoples *Νυβηνῖται* and *Νύκτιοι*. H. KEES, *PW*, XIX/1, 407-15, gives a hist. treatment of *Pelusion*. P. W. HARSH, *Angiportum, Platea and Vicus*, *Cl. Phil.* 32, 44-58, cites the various meanings of the Greek term *ἄφοδος* to illustrate the Latin *vicus*.

F. CHRONOLOGY

L. LAFFRANCHI, *Nota sulla Data LHA delle monete alessandrine di Gallieno* (*Aeg.* 17, 25–8), proposes to explain $\eta\alpha$ not as = 9, but as $\xi\tau\omicron\varsigma \eta \kappa\alpha\iota \alpha$, i.e. of Gallienus and Macrianus (and Quietus), the latter therefore being recognized in Egypt as co-regents. M. J. BOYD, *The Chronology in Porphyry's VITA PLOTINI* (*Cl. Phil.* 32, 241–57), discusses the papyrus chronology for the reign of Claudius II, though without being able to bring forward any new material, and rejects the suggestion, first made by DESSAU, that Plotinus' biographer is reckoning by Egn. regnal years. W. SESTON, *Recherches sur la chronologie du règne de Constantin le Grand* (*Rev. ét. anc.* 39, 197–218), corrects the accepted chronology.

5. Social Life, Education, Economic History, Numismatics

A. SOCIAL LIFE AND EDUCATION

In regard to Social Life, T. A. BRADY's study of *The Gymnasium in Ptolemaic Egypt* (*Univ. Missouri Stud.* 11 (1936), 3, 9–20) is important: also E. KIESSLING's *Zum Katökenproblem in Aegypten* (*Forsch. u. Fortschr.* 13, 392): there is some material in S. EITREM's *Remarks on σπονδή, θαλλός and other extra payments* (*Symb. Oslo.* 17, 26–48). A brilliant book by F. CUMONT, *L'Égypte des astrologues* (Brussels) recreates the contemporary scene from the data furnished by astrological writings of the Graeco-Rom. period. Enriched with nn. (including illu. from papp.) by Mlle C. PRÉAUX, it deserves the closest study.

The methods of education are discussed or illustrated by P. COLLART, *Les papyrus scolaires* (*Mél. Desrousseaux*, 69–80) and *La devinette de la chauve-souris* (*Mél. Maspero* 2, 213–17); see also T. C. SKEAT, *A Greek mathematical tablet* (*Mizraim* 3 (1936), 18–25).

Additions to the facts for the study of Graeco-Egn. art in this period are to be found in A. ADRIANI, *Sculture del Museo Greco-Romano di Alessandria*, III and IV (*Bull. Soc. arch. d'Alex.*, N.S., 9, 3–25 and 190–210), B. HABACHI, *Two tombs of the Roman epoch* (*ibid.*, 270–85), V. CHAPOT, *L'Horus garde-frontière du nome Sethroite* (*Mél. Maspero* 2, 225–31), C. PICARD, *Observations sur l'origine et l'influence des reliefs pittoresques dits 'Alexandrins'* (*op. cit.*, 313–33) [important], and E. MICHON, *Plaque d'or décorée de reliefs de travail Copte* (*op. cit.*, 357–61).

B. ECONOMIC HISTORY

Little has been published on Economics: there may be noted A. ANDRÉADÈS, *De l'origine des monopoles Ptolémaïques* (*Mél. Maspero* 2, 289–95), and F. HEICHELHEIM, *Zu Pap. Michigan III. 173* (*Aeg.* 17, 61–4).

C. NUMISMATICS

The only contribution to Numismatics seems to be L. LAFFRANCHI, *Nota sulla data LHA delle monete alessandrine di Gallieno* (*Aeg.* 17, 25–8), for which cf. § 4 F above.

6. Law

A. GENERAL

(i) Bibliography.

U. WILCKEN, *Urkundenreferat*, *Archiv* 12, 218–47. L. WENGER, *Juristische Literaturübersicht*, VI, *ibid.*, 247–314 includes works up to 1936. Pp. 257–67 are devoted to PIRENNE's three vols. E. SEIDL, *Juristische Papyruskunde, Neuerscheinungen bis Sept. 1936*, *St. et doc.* 3, 213–29; *bis Sept. 1937*, *id.*, 4 (1938), 278–89. A. CALDERINI, *Bibliografia metodica, Diritto e amministrazione*, *Aeg.* 17, 168–74, 312–14, 509–10; *Testi recentemente pubblicati*, *ibid.*, 104–8, 283–4, 479–82. In *BZ* 37 the section *Jurisprudenz* occupies pp. 272–7, 581–9. P. COLLART, *Bulletin papyrologique XVI* (1936), *Rev. ét. gr.* 50, 405–42. List of doctorate theses relating to the hist. of institutions, *Rev. hist. dr.* 16, 180–3 (*Dr. oriental et dr. romain*, 180). J. ERNST (sous la direction de J. MAROUZEAU) *L'année philologique* 10 (1936): *Papyrologie* 164–9, *Droit* 384–91. *Arch. hist. dr. or.*, of which the first annual vol. appeared in 1937 (Brussels), under the general editorship of J. PIRENNE, is divided into three sections, *Orient Ancien*, *Orient Gréco-romain*, *Orient Médiéval*. The publ. of texts and legal vocabularies is to be a special feature. Sectional bibliographies will begin in the second volume.

(ii) Oriental influence. *Reichsrecht* and *Volksrecht*.

E. VOLTERRA, *Diritto romano e diritti orientali* (Bologna), is divided into three parts. The first describes the attempts, sometimes fantastic, beginning as early as the 16th cent., to trace connexions between

Rom. law and Biblical or other Oriental systems; the second refutes in some detail attempts to derive R. l. from other systems of antiquity, while the third examines specific institutions, known to the anc. East, but not to Quiritarian law, which appear in the later Empire. These are few and concern chiefly the law of the family. V. holds that there was no attempt to unify the law of the Empire before Diocletian, who was bent not merely on defending R. l. against the inroads of popular law, but tried to replace provincial by Rom. principles. This attempt died with Diocletian, and the unification sought by Theodosius II was different in that it combined Rom. with local elements. Fundamentally V. is, as he says in a footnote added in the proof, in agreement with E. SCHÖNBAUER, *Reichsrecht, Volksrecht u. Provinzialrecht*, *Z. Sav.* 57, 309–55, who amplifies the contention put forward in *Z. Sav.* 51 (*JEA* 18, 95) that MITTEIS was mistaken in regarding the *CA* as a brutal attempt to force Rom. law on the whole Empire. Neither before nor after 212 was there unity of law: there was *Reichsrecht*, i.e. principles laid down for the whole Empire, *Volksrecht*, i.e. *ius proprium* of a community and based on autonomous regulation, and *Provinzialrecht*, i.e. principles based on official promulgation, such, e.g., as those concerning the βιβλιοθήκη ἐγκτήσεων, which may in substance be derived from native systems. There was no rule that each man should live by his own law, only a general policy not to interfere with existing arrangements (cf. *Studien zum Personalitätsprinzip*, *Z. Sav.* 49, 345–403; *JEA* 16, 134), nor any guarantee that *Volksrecht* would not be overruled. Pressure towards unification begins, however, not with the *CA* but (as with language, cf. WILCKEN, § vi below) under Diocletian, and then such peculiarities as remain gradually assume the appearance of local customs. SCHÖNBAUER, as in *Z. Sav.* 54, 337–8, accepts WILHELM'S reconstruction of P. Giss. 40, and the view that the *CA* was comprehensive. BUCKLAND'S *Edictum Provinciale*, *Rev. hist. dr.* 13 (1934), 81–96 (*JEA* 21, 100) is not quoted. L. WENGER, *Nationales, griechisches u. römisches Recht in Ägypten*, *Atti IV Congr. Int. Pap.*, 159–81, writes in general terms of what has been and may be accomplished with respect to a legal hist. of Eg., as the most promising part of a general legal hist. of antiquity. He accepts WILHELM'S reconstruction of P. Giss. 40, with the deduction that non-Rom. elements continued to flourish, not only in spite of the Rom. law, but with Rom. sanction, and ends with a short but illuminating discussion of the limits of the principle of personality. In *Ludwig Mitteis*, *Arch. hist. dr. or.* 1, 181–211, WENGER discusses the development of research on the lines laid down by M., and emphasizes particularly the truth of M.'s view that Gk. law was a unity. Recent work on the spread of Gk. ideas and their relationship to Oriental systems is also briefly mentioned, and WILHELM'S reading of P. Giss. 40 together with SCHÖNBAUER'S general ideas accepted.

(iii) Christian influence.

C. HOHENLOHE, *Einfluss d. Christentums auf d. Corpus iuris civilis*, Vienna, fervently upholds the view that the law of the later Empire is deeply influenced by Christian doctrines, and that the great Romanists of the 19th cent. failed to recognize the change from classical 'individualism' which had been thus brought about. He also repeats his view (*Collatio legum Romanarum et Mosaicarum*, Vienna, 1935; revd. *Z. Sav.* 56, 361–2) that St. Ambrose was the author of the *Collatio*, because he wanted to make clear how much the secular law needed alteration by showing how like it was to the Mosaic law which had for the most part been superseded by the coming of the Messiah. The book deals with modern as much as with historical problems.

B. BIONDI, *Giustiniano primo, Principe e Legislatore Cattolico* (*Pubbl. dell'univ. cattolica del Sacro Cuore*, vol. 48), Milan, 1936, is not directly concerned with the influence of Christianity on the law, but intended to defend Justinian against the constantly reiterated charge of Caesaropapism. J. expressly admits the force of *canones*, and when he incorporates their contents in his legislation this is not to give them a validity which they would lack without state authority, but merely a form of recognition which also serves the same purposes as those of a private collection.

(iv) The oath.

B. KÜBLER, *KVGR* 28 (1936), 295–305, reviewing favourably SEIDL, *Der Eid*, II, disagrees with S.'s view that the Christians excused themselves for taking the oath by the emperor's *τύχη*, on the plea that this was merely a 'Fluchobjekt', the oath itself being by God. K. thinks this would have been *maiestas*. Even after the introduction of Christianity, he explains, the emperor remained semi-divine, 'with one foot in heaven'.

E. SEIDL, *KVGR* 29, 245–9, reviewing F. LL. GRIFFITH, *Catalogue of the dem. graffiti of the Dodecaschoenus*, adds some points of interest, e.g. that the imperial oath is shown not to have ousted the oath by supra-terrestrial gods among the native population in the 1st cent.

(v) Diplomatic.

E. SEIDL, *Demotische Urkundenlehre nach d. frühptolemäischen Texten*, Münch. Beitr. 27, publs. the paper read at the Oxford Congress, together with a chronological list of docs. from Alexander's time to the end of Philadelphus' reign, with which period alone he is here concerned. He distinguishes three main categories: (1) the Egn. 'scribe and witness doc.', (2) the 'double' doc., and (3) the bilingual doc. in Gk. and dem., agreeing with PARTSCH that (1) probably needed delivery (*traditio chartae*) to become effective. Sealing is very rare and certainly not necessary. As regards (2) he agrees with KUNKEL (*St. Riccobono* I, 415 (1936)—not seen) that they represent a reception of a Gk. form. The chief interest of P. Mich. Inv. 508 (a Latin marriage contract, prob. 1st-2nd cent.), publ. by H. J. WOLFF, *Aeg.* 17, 470-8, lies in its form, which W. believes to be an independent Rom. adaptation to pap. of the double doc. as commonly written on tablets. The doc. is folded in the middle, and the witnesses' signatures are written (in Gk. characters) outside at right angles to the internal lines, together with a few letters that may represent a Gk. summary. F. CUMONT, *C.-R. Ac. Inscr. et B.-L.*, 313-16, gives the text of a fragmentary inscr. found at Susa in 1937, consisting chiefly of the names of witnesses to a contract. At least two are *χρεοφύλακες*, but C. B. WELLES suggests a restoration which would place the *ἐπιστάτης* before them, as at Dura. The latter scholar, in *Arch. hist. dr. or.* 1, 261-84 publs. Dura P. 101 (A.D. 227) to which W. KAMPS adds *Résumé, Analyse et Index juridiques* (284-8). Diplomatically the interesting feature is that the signatures on the verso are found opposite knots in the string which kept the upper text closed. The doc. is a purchase by a veteran of a vineyard, mainly Rom. in form.

(vi) Various.

U. WILCKEN, *Ueber den Nutzen d. lateinischen Papp.*, *Atti IV Congr. Int. Pap.*, 100-22, among much else of legal interest, connects Diocletian's abolition of the old *ὑπομνηματισμοί* (BICKERMANN, *Aeg.* 13, 344 ff.; *JEA* 20, 98) with the introduction of Latin for the framework of the individual *gesta* which replaced them. The judgements, however, though originally in Latin only, are accompanied by transls. as early as the fourth century, and in the fifth are only in Gk. For the earlier period it is a rule that whereas the emperors answered letters in the language in which they were written, the *subscriptiones* to *libelli* were always in Latin. In *Archiv* 12, 235, W. finds confirmation of this rule in P. Harr. 67. O. GUÉRAUD, *Mél. Desrousseaux*, 199-209, publs. a short *κεφάλαιον ἐγ διατάγματος* of Haterius Nepos which orders *παστοφόροι* and lesser assistants (*χρεακοί*) to confine themselves to their proper work and not to wear wool (*cf.* Gnomon, §§ 71 and 74-6). He conjectures that it may have been copied for the information of some office of the Idios Logos, and that the *ἐν μέσῳ κεφάλαια* of the Gnomon were, like it, docs. that had accumulated in an office chosen because they were 'easy of access', as opposed to many which in the course of time would have got mislaid or destroyed. The fragm. (probably 4th cent.) corresponding to part of D.12.1.1.1. which was discussed by F. DE ZULUETA at the Oxford Congress, 1937, is reprinted in *Bull. Ist. dir. rom.* 43 (1935), 408, and is to appear with others in P. Rylands III. As D.12.1.1.1. was believed to be heavily interpolated the discovery is important. J. C. NABER, *Ad Octavianas 'Εντεύξεις quasdam*, *Arch. hist. dr. or.* 1, 239-48, contains textual suggestions and other nn. on OCTAVE GUÉRAUD's edn.

B. LAW OF PERSONS

(i) Census. Poll-tax. Colonate.

V. MARTIN, *Recensement périodique et réintégration du domicile légal*, *Atti IV Congr. Int. Pap.*, 225-50, concludes that there is insufficient evidence to support ROSTOVITZEFF's view that edicts ordering people to return to their *ἰδία* were regularly issued in connexion with the census. The mention of the census in the edict of Vibius Maximus (W., *Chr.*, 202) is introductory and accidental, the real object being, as is said immediately afterwards, to secure the presence of the population for agricultural work. There is evidence, however, that such edicts were in several cases issued at the beginning of their author's term of office. A new reading and interpretation of the last lines of W., *Chr.*, 202 is given pp. 236-7.

M. HOMBERT and CL. PRÉAUX, *Chron. d'Ég.* 12, 259-64, publ. with comments the certificate of exemption from *λαογραφία* in the name of Mettius Rufus found among the collection of the Fondation Égyptologique (*JEA* 23, 98). Though *ἀσθένεια* often means poverty they believe that here *ἀσθενής* refers to exemption on the ground of illness. H. I. BELL, *JEA* 23, 135-8, reviewing very favourably CL. PRÉAUX, *Les Ostraka grecs de la Collection C. E. Wilbour* (1935), disagrees on poll-tax. This was not a Rom. innovation intended to mark the politically inferior status of the conquered, but a means of raising revenue taken over from Ptol. times, as the Arabs later took over the Byzantine *ἀνδρισμός*. The distinction was not between conquerors

and conquered, but between members of Gk. citizen bodies (together with katoikoi) who paid at a reduced rate, and Egyptians, *λαογραφούμενος* meaning 'paying the full poll-tax'. If the tax had marked inferior status it would not have survived the CA. For *λαϊκός* = 'native of', cf. PER Inv. 24552 below, B (iii). CH. SAUMAGNE, *Du rôle de l'origo et du 'census' dans la formation du colonat romain, Byzantion*, 12, 487-581, throws light upon the hist. of the distinction between *adscripticii* and other *coloni*, but from legal, not papyrological sources. For the Ptol. census see now P. Harr. 61 (decree of Philometor). I have not seen A. CALDERINI, *Nuovi studi sulle schede di censimento, Misc. Nogara* or CL. PRÉAUX, *Les Modalités de l'attache à la glèbe dans l'Ég. grecque et romaine, Recueil de la Soc. J. Bodin*, 35-66.

(ii) Registration of Birth.

H. I. BELL, *A Latin Registration of Birth, JRS* 27, 30-6, publ. one leaf of a diptych, of A.D. 127, similar to that publ. by H. A. SANDERS, *AJA* 32 (1928), 308-29, but mentioning that the attestation is made in view of future *epicrisis* after the father has been discharged from the army.

H. A. SANDERS, *A Birth Certificate of 138 A.D. Aeg.* 17, 233-40, publ. P. Mich. Inv. 3994, in which the failure to make *professio* is said to be (*propter districtionem militiae*, which proves that S.'s expansion of *districtionem mil.* in BGU 1690 is correct. From the words *se testari ex lege Ael.*, etc., S. infers that the *leges Aelia Sentia* and *Papia Poppaea* not only forbade the registration of illegitimate children at the record office, but also directed the use of this method of attestation before witnesses.

K. F. W. SCHMIDT, *GGA* 199, 147-56, reviewing P. Mich. III expands *c. r. e. ad k.* in the registrations of birth (nos. 166-8) as *causa relata est ad kalendarium*, meaning 'the case has been notified at the proper time'. *c. r.* cannot mean *civis Romanus*, for the superscription shows that the facts registered were not verified (*contra causarum cognitionem*) and citizenship could not be proved by a *kalendarium*. In No. 169 *b(inae) t(abulae)* cannot refer to the 'double' nature of the doc., but is used because there was one copy for each of the twins. For birth certificates cf. H. I. BELL's rev. of P. Mich. III in *JRS* 27, 280-1.

(iii) Slavery.

H. LIEBESNY, *Aeg.* 16 (1936) 257-91, publ. PER Inv. 24552, which contains two *προστάγματα* relating to Syria and Phoenicia probably of Ptolemy II, the first ordering returns of cattle, the second ordering return and production before the *οικονόμος* of *σώματα λαϊκά ἐλεύθερα* held in slavery. A further prohibition of the sale or mortgage of such *σώματα* except *τῶν ὑπὸ τοῦ διοικοῦντος τὰς κατὰ Συρίαν καὶ Φοινίκην προσβολῆ δδομένων* he takes to favour the view of SCHÖNBAUER and others (*JEÄ* 19, 85) against WESTERMANN, that execution leading to actual slavery was not permitted, even by agreement, except in the case of fiscal debtors, and to confirm SCHÖNBAUER's reading (*Z. Sav.* 46, 206) *προ[σ]βολῆν τ[ῆ]σθαι* in P. Teb. 5 (M., *Chr.*, 36), 225. ARANGIO-RUIZ, *Una nuova iscrizione sul protettorato dei Tolemei in Cirenaica, Riv. di fil.* 15, 266-77 (cf. G below), agrees, assuming that Philadelphus' successors restricted the powers of officials to the mere arrest of fiscal debtors, and that Euergetes II (P. Teb. 5) forbade even this. The Cyrenaic *πρόσταγμα*, which forbids execution against the person without previous authorization of the *χρηματισταί*, he takes to have been analogous in its original Egn. formulation to Euergetes' decree, and, as at first drafted, to have referred to officials only, with the object of extending the same principles to Cyrenaica. But as it was feared that officials there might be in a position less favourable than that of private individuals, the words *ἢ τῶν ἄλλων κ.τ.λ.* were added, and the Cyrenaeans thus recommended to apply the same limitations to proceedings under their own municipal statutes. W. L. WESTERMANN, *Enslaved persons who are free, Am. Journ. Phil.* 59 (1938), 1-30, maintains his original view, holding that the new pap. confirms the reading *ἐλεύθερα* in P. Col. Inv. 480, but not KOSCHAKER's and SCHÖNBAUER's interpretation as 'free from mortgage'. LIEBESNY, by interpreting *λαϊκός* as 'native', whereas it refers only to the lower classes, and by defining too narrowly the law *ἐπί τῆς μισθώσεως* (l. 22) which laid down conditions of enslavement, has narrowed unduly the sphere in which it was possible. He also quotes an unpubl. *ἐντεύξις*, P. Col. Inv. 272, of 245 B.C., where the burden of the complaint is that the creditor has arrested and detained a free person on *his own authority*, whereas it seems that an application to the *πράκτωρ* for the purpose would have been lawful. W. also holds (against WILCKEN, *Archiv* 12, 223) that although striking likenesses between PER Inv. 24552 and the alleged decree of Philadelphus ordering a mass liberation of Jewish slaves (Pseudo-Aristeas, 22-5) go to show direct borrowing, the latter is none the less forged.

G. R. MORROW, *The Murder of Slaves in Attic Law, Cl. Phil.* 32, 210-27, argues that the *γραφὴ ὕβρεως* gave some protection to slaves, even against masters, though its efficacy was limited by the fact that only a free person could prosecute and that a prosecutor ran the risk of a penalty if he failed.

(iv) Guardianship.

P. Mich. Inv. 6659, publ. by H. J. WOLFF, *Aeg.* 17, 463–70, probably of Nero's reign, is a woman's petition to the exegete to appoint a guardian for the purposes of a divorce *συγχώρησις*, a peculiarity being that the divorce has already taken place. W. thinks that with other docs. it provides the evidence (denied by M., *Grdz.*, 253) that some relatives became tutors *ipso iure* among *peregrini*.

(v) Marriage.

P. KOSCHAKER, *Die Eheformen bei den Indogermanen, Deutsche Landesreferate zum II. Internat. Kongr. f. Rechtsvergleichung im Haag, 1937, Sonderheft d. elften Jahrg. d. Zeitschr. f. ausländisches u. internationales Privatrecht*, 77–140 b., though not touching papyrology directly is indispensable for any study of anc. marriage. Two forms of betrothal are distinguished, one of an arrhal nature, which corresponds to an incomplete transfer by sale, the other more purely promissory. 'Εγγύησις belongs to the former type, but K. seems to suggest that the distinction between ἐγγ. and ἐκδοσις might rest on the completion of an inchoate transaction. However, he does not say that, and characterizes the problem as 'unsolved, perhaps insoluble'. The connexion worked out between epiclerate and 'free' marriage by the use of comparative material is of fundamental importance. F. DE ZULUETA gives a summary of the paper, *LQR* 54 (1938), 120–3.

C. LAW OF PROPERTY

(i) καταγραφή.

E. SCHÖNBAUER, *Zur Frage d. Liegenschaftserwerbes im Altertume: Das Recht d. Katagraphe, Atti IV Congr. Int. Pap.*, reasserts his view, which he now calls the 'protocol theory', against RABEL's (*Z. Sav.* 54, 188–232; see *JEA* 21, 95) 'register theory' and SCHWARZ's 'document theory'. He agrees with R. and others that MITTEIS's view of κ. as equivalent to the dem. 'doc. of withdrawal' must be given up, but not with R.'s explanations by comparison with the Germanic separation between sale and investiture, for there is no connexion of blood or civilization between Egyptians and Germans, and the German withdrawal is from the land itself, not from rights to it. BGU 998, believed to be the result of Egn. influence, is a declaration before a public authority, and as such totally different from the 'individualistic' native document. R.'s views are not always consistent and require too many meanings for κ.; no mere register could contain all the particulars to be entered according to P. Hal. 1; ἐπί in the Tenos inscr. and in P. Col. Inv. 480 must mean 'before' the magistrates (cf. BICKERMANN, *Aeg.* 13, 333–55; *JEA* 20, 98); Pg. Dura 23 calls itself a κ. and is made before public officers; R.'s explanation of ἀμφούριον in P. Hal. 1 is unacceptable as against WILHELM's 'Grenzgeld', nor can the reading ἀπο[λάβη τὴν τιμὴν] be right. It cannot have been possible for the seller, as R. thinks, to vindicate after κ. had taken place even though he had not received the price. Against SCHWARZ the chief argument is still that his theory cannot connect Ptol. and Rom. practice, and that it is too individualistic to be compatible with Theophrastus' requirement of publicity in all acquisitions of property. The rarity of refs. to κ., which seems surprising on SCHÖNBAUER's theory, he explains by the very fact that κ. was an official documentation laid down as essential by statute and therefore requiring no special mention. It does not occur in the Hermias trial because that is, as WILCKEN has shown, concerned with possession, not ownership.

(ii) Emphyteusis.

H. COMFORT, *Emphyteusis among the Papp.*, *Aeg.* 17, 3–24, examines the relevant docs., all subsequent to Zeno's constitution, including some Cop. ones. The difficulties in P. Cair. Masp. III 67299, in particular that the lessee is to be allowed εἶτε εἰς βελτίονα εἶτε εἰς χείρονα ἐνέγκειν ὄψιν, which is contrary to the rules of emphyteusis, are perhaps to be explained by regarding it as *superficies*, for which ἐμφυτεύειν was also used.

(iii) Mortgage.

E. SCHÖNBAUER, *Rechtshistorische Urkundenstudien z. griechischen Recht im Zweistromlande. I: Pg. Dura 21, Archiv* 12, 194–217, defends his own view of ἀνανέωσις against WELLES (*Z. Sav.* 56, 99–135; *JEA* 23, 100); like the other Dura docs. Pg. 21 is perfectly explicable on Graeco-Hellenistic lines and the notarial function of the court has no connexion with Oriental influence. The hypothec was probably not general, πάντα ὑπάρχοντα referring back to some noun which is not preserved in Pg. 21 or 32. The manumission by dedication from Susa (F. CUMONT, *Mém. de la mission archéol. de Perse*, xx, 84–8; *JEA* 18, 94), as now restored by L. ROBERT, *Rev. de phil.* 10 (1936), 137–48, no longer gives any support to KOSCHAKER's and SAN NICOLÒ's views (*JEA* 19, 83), but is a purely Gk. form of manumission. On ἀνανέωσις in P. Oslo 118 see WELLES, *AJA* 41, 508–12.

A. B. SCHWARZ, *Sicherungsübereignung u. Zwangsvollstreckung in d. Papp. (aus Anlass von Stud. Ital. XII), Aeg. 17, 241–82* (cf. *JEA* 22, 69) regards the doc. on pp. 103 ff. as an example of a mortgage which is neither *ὑποθήκη* nor *ὑπάλλαγμα*, but an alienation subject to a suspensive condition, characterized, like P. Oslo II 40, by the use of the word *μένειν* to describe the creditor's right if the debtor defaults, and therefore capable of being described in the terms which P. Oslo II 40 B applies to A, as a security *ἐπὶ κυρία*. There is little apparent difference between such security and a *ὑποθήκη*, but S. points out that the *μένειν* docs., so far as they refer to land, give the creditor the right to ask for registration of *κατόχη* in the *βιβλ. ἐγκτ.*, whenever he desires, perhaps because this would not be possible (as with *ὑποθ.* and *ὑπαλλ.*) without express permission. Classing the doc. as *ἐπὶ κυρία* does not, however, explain how it comes that the creditor can levy execution against the debtor's property generally. This, S. thinks, is due to another peculiarity of the *μένειν* type, *i.e.* that it definitely gives the creditor the choice (*ἐκλογή* as in P. Oslo II 40) between relying on the ownership clause and general *πράξις*. There are a number of circumstances in which, despite a clause giving the creditor ownership in case of default, *πράξις* may become permissible, and P. Teb. III 817 of 182 B.C., which stipulates for personal liability, with a penalty for delay, in case of failure to guarantee or *κωδινός*, warns us how early Ptol. law overcame the conception of liability restricted to the object pledged. On the procedural side S. finds support for his view that it is only in case of chirographs, as opposed to public documents, that *Mahnverfahren* was a necessary preliminary to *ἐνεχυρασία*, and believes that *διαλογεῖσμοῦ* in line 59 must be a slip for *διαλογῆς*.

P. JOUGUET, *Mél. Desrousseaux*, 229–38, publs. a receipt of 75 B.C. in the form of a *συγγραφή ἐξαρτύρου* which has reference to a debt originally secured by the *ὁμολογία πράσεως* of a cow—a rare instance of *ἀνή ἐν πίστει* of movables.

D. LAW OF OBLIGATIONS

(i) Egyptian contracts.

R. TAUBENSCHLAG, *Le Droit contractuel ég. d'après les pap. grecs, Arch. hist. dr. or. 1, 249–59*, summarizes the refs. to 'Egn.' contracts under the heads of marriage obligations, security, succession, and procedure. The contracting parties are, except in one case, either all of Egn. nationality or mixed. As the form of the doc. governs the competence of the court, so also the parties can, by choosing either a Gk. or an Egn. form, determine the law that is to be applied.

(ii) Loan.

J. CVETLER, *Le cosiddette 'anticipazioni' nell'economia rurale dell'Egitto tolemaico, Atti IV Congr. Int. Pap., 283–91*, summarizes another part of his Czech work on *mutuum* (cf. *JEA* 22, 85), treating of advances of seed-corn and advances made to tenants for clearing land. When these latter are to be repaid in any case it is because the tenant himself will benefit by the improvement; when they are only to be repaid if the work is not done, it is because, as with *βασιλικοὶ γεωργοί*, the tenant has no claim to the crop.

P. H. DE LACY, *JEA* 23, 76–80, publs. P. 7741 of the Garrett Deposit Collection, Princeton, of A.D. 52, an acknowledgment of repayment of a loan made by three brothers to their sister and her husband on the terms that the creditors were to be allowed to occupy some buildings. A peculiar feature is that one brother receives the share of another who is absent and guarantees the borrowers against any claim by him.

CL. PRÉAUX, *Une Reconnaissance de dette du IVe siècle après J-C (P. Wilbour Brooklyn Gr. 1), Arch. hist. dr. or. 1, 289–302*, adds a brief comm. on the hist. of the standard phrases in this 'doc. banal'. *Analyse et Index juridiques* by W. KAMPS, *ibid.*, 302–4.

(iii) Locatio conductio.

R. TAUBENSCHLAG, *Prozesse aus Pacht-, Miets-, Dienst- u. Werkverträgen in d. griechischen Papp., Archiv 12, 187–93*, gives a summary of the points arising in these cases.

S. EITREM, *Symb. Oslo. 17, 26–48*, examines '*Σπονδή, θαλλός and other extra payments*' in kind or money such as occur frequently in connexion with leases and contracts of service, and appear commonly to have a religious origin. He refuses to accept WILCKEN's explanation of *θαλλός* in P. Par. 62 III 15 as a palm-branch given to the successful bidder at the auction, and thinks it is derived rather from the 'extra payment' customarily required from a lessee.

(iv) Societas.

W. KAMPS, *Les Origines de la fondation culturelle dans la Grèce anc., Arch. hist. dr. or. 1, 145–79*, combats E. F. BRUCK's view that these foundations are due to testators' mistrust in their descendants'

willingness to carry out family worship. Their growth is connected with the rise of the 'small' family, the evolution being the reverse of that given by PIRENNE for Eg., where individualist and then family foundations precede the completed family solidarity of Dyn. 6. Annam, however, provides close parallels to Greece.

P. J. T. ENDENBURG, *Koinoonia en gemeenschap van zaken bij de Grieken in den klassieken tijd*, Amsterdam, is largely concerned in tracing shades of meaning, and does not, except occasionally, use material later than Aristotle. The general legal result (according to the summary in German) is that no settled forms were developed, such partnership as existed being generally entered into, not for the purpose of making great amounts of capital available, but simply for the distribution of risk in short-lived undertakings. There are vague similarities with *société en commandite* but no nearer approximations to modern forms.

H. LEVI-BRUHL, *Le 'consortium' artificiel du Nouveau Gaius*, *Atti IV Congr. Int. Pap.*, 293-304, gives in full the argument for his view that the *consortium* was a true joint-family, possible only between relations, or at least members of the same *gens* between whom there was community of cult (cf. *JEA* 23, 100).

A. E. R. BOAK, *Am. Journ. Phil.* 58, 210-19, gives a preliminary report of P. Mich. Inv. 657, which is to be publ. in Pt. II of the *Michigan Papp. from Tebtunis*. It is an agreement entered into by the salt merchants of Tebtunis for A.D. 47-8 in the form of an ordinance, and shows that the merchants were probably organized as a guild. No member is to sell for less than the prices agreed for the three grades of salt.

(v) Agency.

E. RABEL, *Systasis*, *Arch. hist. dr. or.* 1, 213-37, after explaining that the word as used in the Attic orators by no means implies authority to act legally on behalf of another, finds much the same result for Ptol. law by examination of the Serapeum papp. In the 2nd cent. B.C. representation, in particular for the purposes of litigation, is not allowed, and must be specially asked for in each case (cf. P. Teb. III 770, editor's n.)—a position for which there are close parallels in the Middle Ages. A few pages on *systasis* in the Rom. period end with the remark that no unequivocal evidence on the question of direct representation is provided by the use of the word.

(vi) Suretyship.

M. SAN NICOLÒ, *Zur Nachbürgschaft in d. Keilschrifturkunden u. in d. gräko-ägyptischen Papp., Sitzungsb. München, Phil.-hist. Abt.*, Heft 6, Munich (50 pp.), examines cases of suretyship for a surety occurring in the Neo-Babylonian docs. connected with the temple of Eanna at Uruk, and finds some papyrological analogies. Neither in Babylonia nor in Eg. does the phenomenon occur in private law, but as the Temple authorities at Eanna found it necessary to take these precautions to secure the services of hieroduli who were apt to attempt escape from their burdensome obligations, so when the burden of liturgies became unbearable the Rom. authorities, and in the period of *ἀντροπαγία* the landlords, used similar methods. Four cases are given, PSI IV 289; BGU I 244; PSI III 162; and that publ. by DONADONI, *Aeg.* 15 (1935), 207-8, the last referring, however, probably not to a liturgy, but to the presence of a party for the purposes of legal proceedings, which had presumably already begun. We may perhaps add now P. Harr. 65, a case of bail for a man whose son had been sent to the prefect's court to answer charges against him. Possibly, as the editor, J. E. POWELL, says, the father was bail for his son, but gaps in the text make this very uncertain.

P. Berol. Inv. 16374 Recto (A.D. 538, Antinoopolis), one of two docs. publ. by S. G. KAPSOMENOS, *BZ* 37, 15-17, is an indemnity given by a person appointed to collect taxes on an estate (cf. P. Oxy. I 136) to the person who has gone surety for him. As in P. Oxy. I 125, all the promissor's property, past and present, is hypothecated.

(vii) Negotiable instruments.

V. ARANGIO-RUIZ, *Il problema dei titoli al portatore in un nuovo papiro di Tebtunis*, *Atti IV Congr. Int. Pap.*, 251-8, derives arguments in favour of the view that something like negotiability existed from the report of a case of A.D. 127 in which the plaintiff relies upon a doc. which is in the name of another. The pap. is to be publ. in the next Milan volume.

(viii) Discharge of obligations.

G. LA PIRA, *La stipulatio aquiliana nei papiri*, *Atti IV Congr. Int. Pap.*, 479-84, explains historically the illogical coexistence of *stip. Aq.*, with a *pactum transactionis* and penal stipulations in Byzantine papp. (e.g. P. Lond. Inv. 2017). The restriction of the effect of *stip. Aq.* to matters that the parties had in mind is classical reception into civil law of principles derived from the praetorian *pactum*, but when it was desired to secure extension to all matters this was expressed by a ref. to the *stip. Aq.*, which originally had that effect. This is post-classical.

E. THE LAW OF SUCCESSION

C. A. MASCHI, *La solennità della 'heredis institutio' nel d. r.*, *Aeg.* 17, 197–232, argues that the relaxation of rules of form for *institutio heredis* in later classical law was a progressive process under the influence of praetorian indifference to formality, and that Constantine's enactment of 339 (C. 6.23.15) was no innovation. The constitution of Alexander Severus, evidenced by Pap. E. R. 1702, allowing the use of Gk. in wills, was no mere act of tolerance (as MITTEIS held), but fits in with many examples in the Digest of the interpretation of Gk. wills.

F. THE COURTS AND PROCEDURE

L. GERNET, *Sur la notion du jugement en droit grec*, *Arch. hist. dr. or.* 1, 111–44, starting from the conception of the court as umpire concludes that in Attic law (to which he confines himself) even at its most developed stage the function of a judgement was not to recognize pre-existing subjective rights but to settle a quarrel. He denies the validity of the distinction between *δίκαι κατά τινος* and *πρός τινα*, holding in effect that all actions are delictal. E. SEIDL and B. H. STRICKER, *Studien zu Pap. B M eg. 10591*, *Z. Sav.* 57, 272–308, after summarizing the hist. of the case with which THOMPSON'S *A Family Archive from Siut* (*JEA* 21, 92) is concerned, raise several points of procedural and substantive interest. They regard the identification of the trial court with the *laocritae* as doubtful, for in all known cases in which, as here, the judges are priests, the parties and matters in dispute are also of a priestly character, and the jurisdiction may be a special one. In general the inquisitorial nature of Egn. procedure is held to be confirmed, and a former suggestion of SEIDL'S that one of the persons mentioned might have been called as a witness by a party (*JEA* 22, 87) is withdrawn. The procedure is native, with some Gk. innovations, such as the *είσαγωγείς* and the *ὑπόμνημα* to the strategos, and it is shown that the strategos is under a duty, if he cannot succeed in mediating between the parties, to send the case for trial to a court designated by law. The problematical 'valuation' does not represent a reception of *τίμημα*, but is a proceeding intended to safeguard one's right. If something is done which might interfere with a man's rights, he must either bring an action or execute a deed of valuation with sixteen witnesses. Otherwise he will be estopped after a certain time from complaining of the interference. There is an interesting analysis of the elaborate forms of pleading on pp. 292–4. For substantive law the main point made is that in the 2nd cent. at any rate the *κατοχή* of children in their parents' property is now shown not to be given directly by the law of succession but to be based on settlements, which once made cannot be revoked. From a new reading in BM 10598 l. 14 the authors conclude that Tefhape sued Tuot for 'Ackernutzen'. For this claim cf. TAUBENSCHLAG, *Z. Sav.* 55, 283 (*JEA* 22, 84) on *δίκη καρπού*. H. KORTENBEUTEL, *Zum Sondergericht der Aposkeuai*, *Aeg.* 16 (1936), 292–5, shows from a Berlin fragm., P. 7415, that the special court for soldiers' dependents in the *χώρα* was probably that of the Phourarch.

W. KUNKEL, *Z. Sav.* 57, 401–12, reviewing BERNEKER, *Sondergerichtsbarkeit* (*JEA* 22, 87), criticizes a number of points in detail.

J. N. COROI, *Le P. Oxy. III 471, Une cognitio Caesariana sous Trajan, Atti IV Congr. Int. Pap.*, 395–434, collects apropos of this 'heathen martyr' doc. a great deal of information on the imperial tribunal.

According to a rev. by PAOLA BARISON, *Aeg.* 17, 296–7, G. VISMARA, *Episcopalis Audientia* (*Pubbl. Univ. Catt.*, Ser. II, 54, Milan), contains a chapter on the papyrological evidence, in which he contends that P. Lips. 43 shows a case which was not one of arbitration merely in which the parties approached the bishops' court direct, without previously going to the secular authorities.

H. F. JOLOWICZ, *Case Law in Rom. Eg.*, *Journal of the Society of Public Teachers of Law*, 1937, 1–15, discusses the evidence for citation of precedents, including P. Lond. Inv. 2565 (*JEA* 21, 224–47; 23, 111), and argues for a Rom. rather than a Gk. origin of the practice.

G. PUBLIC LAW

CL. PRÉAUX, *Un Problème de la politique des Lagides: la faiblesse des édits*, *Atti del IV Congr. Int. Pap.*, 183–93, shows how the attempt of the Ptolemies to harness the whole social and economic life of the country to the service of the state, and thus to turn much private into public law, made their legislation weak. The essay is partly an amplification of what the author said, *Chron. d'Ég.* 10 (1935), 343–60 (*JEA* 22, 89).

V. ARANGIO-RUIZ, *Una nuova iscrizione sul protettorato dei Tolemei in Cirenaica*, *Riv. di fil.* 15, 266–77 (cf. B (iii) above), reprinting part of the inscr. (probably 109–8 B.C.) in col. 538 of *Documenti antichi dell'Africa italiana* (II. 2) with comments, takes ll. 3–13 to be the end of the *ψήφισμα* referring to

sacrifices, and thus a municipal, not a royal enactment. It is a mistake to suppose that, *in form*, royal enactments took precedence of all other sources, and ll. 14–26 contain a *recommendation* to ‘the Cyrenaeans’, *i.e.* probably the *κοινόν*, asking only that the gist (*γνώμη*) of the accompanying royal *πρόσταγμα* should be included in the local *δικαστικὸν διάγραμμα*. *Διαγρ.* is a collection of rules on some branch of state activity, but outside Eg. not necessarily royal. In the phrase *τῶν βασιλικῶν προσταγμάτων καὶ τῶν νόμων* (ll. 8–9), *νόμοι* means the municipal statutes, and the antithesis is more common than generally supposed, because of the ambiguity of *νόμος* which can also be used for a legal norm generally, but is never used of the enactment of a Hellenistic sovereign. So in the Empire *νόμοι* came to be opposed to *διατάξεις*, and the late Rom. terminology is descended from the relations between the Ptolemies and the free cities. For these relations see also A. HEUSS, *Stadt u. Herrscher d. Hellenismus, in ihren staats- u. völkerrechtlichen Beziehungen*, *Klio*, *Beiheft* 26, 273 pp., whose main conclusion is that there was never any integration into a monarchical legal system, and that, so far as jurisdiction was concerned, the ruler never did more than support and influence the autonomous activities of the cities.

W. SCHUBART, *Das Gesetz u. d. Kaiser in griechischen Urkunden*, *Klio* 30, 54–69, puts together some of the introductory generalities to be found in docs., and refs. to the different virtues of the emperor, especially in relation to law. The existence of a governor, to whom are ascribed some of the imperial attributes, differentiates the Rom. from the Ptol. position.

7. Palaeography and Diplomatic

A. SIGALAS, *Ἱστορία τῆς Ἑλληνικῆς Γραφῆς* (*JEA* 22, 90), is highly commended in *Phil. Woch.* 57, 997–9, by J. KALITSUNAKIS. I have not been able to see the not. by M. SEGRÈ in *Il Mondo classico* 6 (1936), 362.

G. RUDBERG, *De nominibus sacris adnotatiunculae*, *Eranos* 33 (1935), 146–51 (previously omitted from this section by oversight), is a useful discussion of the examples of *nomina sacra* in the Beatty papp. and P. Lond. Christ. 1. On the origin of *nomina sacra*, however, the author’s speculations are much less satisfactory, and his suggestion that they were modelled on the scrawled forms of the Imperial names and titles in the prescripts of papp. will find few adherents. A reconsideration of the whole problem is urgently needed.

I have not seen an art. by L. TH. LEFORT, *La Transcription des textes mutilés*, *Muséon* 50, 1–4, which may belong in this section. It presumably relates to Coptic MSS.

JERZY MANTEUFFEL, *Wykazy Książek w papyrusach* (= Book-catalogues in the papyri), *Munera philologica Ludovico Cwiklinski oblata* (Posnaniae, 1936), 145–54, is also inaccessible to me.

A popular account of the genesis and development of the codex is given by HUGO IBSCHER, *Der Kodex*, in *Jahrb. f. Einbandkunst* 4, pp. 1–15 (of offprint), 2 pls. It includes, however, some rather surprising statements, *e.g.* that the roll is a finer and more practical form than the codex, or that rolls of vellum are unsatisfactory (what about the many thousands of medieval vellum rolls?): and to suggest that pap. is more durable than vellum is surely a paradox. The reference to pap. codices of Gk. Biblical texts dating from the first cent. A.D. is disquieting (or is it a misprint for second cent. A.D.?), and the statement that Gk. and Coptic pap. codices down to the end of the third cent. (are there *any* Coptic MSS. of this date?) regularly consisted of a single large quire is not correct. In dealing with the Mani codices, however, where he can draw from his unrivalled personal experience, the author is on firmer ground, and has much that is interesting to say about these once-splendid volumes.

C. BRADFORD WELLES, *Dura Papyrus* 101, *Arch. hist. dr. or.* 1, 1–24, though not strictly Egn. papyrology, includes some interesting observations on the rivalry of vellum and pap. at Dura (the latter apparently introduced by the Roman army). There is also a fresh discussion of the vexed question of the ‘double deed’; for further details and for other work on legal diplomatic *cf.* above, § 6 A (v).

P. COLLOMP attempts an explanation of the occasional or even exclusive use of the 2nd pers. pl. in royal letters addressed to a single personage, *La Lettre à plusieurs destinataires*, *Atti IV Congr. Int. Pap.*, 199–207. With considerable reservations he puts forward the suggestion that a general circular letter, written throughout in the 2nd pers. pl., provided the model for individual copies, intended for dispatch to different officials, in which the plural had been generally (but by no means consistently) altered to the singular.

G. PASQUALI, *Storia della tradizione e critica del testo* (*JEA* 22, 90; 23, 103) is revd., on the whole appreciatively, by B. L. ULLMAN in *Cl. Phil.* 32, 371–3; even where he disagrees with the author, ULLMAN pays tribute to the depth of learning and many-sided interests which characterize the work.

8. Lexicography and Grammar

G. GHEDINI, *Studi dedicati alla memoria di Paolo Ubaldi (Pubbl. dell' Univ. catt. del Sacro Cuore, Serie V: Sc. stor.*, vol. 16), Milano, 443–80, offers us 'a rapid glance' at the chief characteristics of the apocryphal gospels and quotes many parallels from the papp. The genitive after καθαρεύω and καθαρός is surely ablative of separation and not 'di ambito'. We are informed that πιστεύω takes εἰς or πρὸς with the accusative when the verb is in the future or aorist (p. 450); but note πιστεύω εἰς τὸν Θεόν BGU 874, 11, etc., and πιστεύσαι τῷ λόγῳ BGU 674, 6. On ἐν and εἰς the author remarks that ἐν + the dative for motion towards is rare in the Koinē. It is quite frequent in the papp., e.g. P. Oxy. 65, 3; P. Flor. 156, 7; P. Ryl. 125, 25, etc., etc. For ἄμα c. genitive cf. P. Oxy. 903, 3; P. Lond. 241, 10, etc. τί θέλεις ποιήσω is quite possibly a Latinism: *quid velis faciam*. With ἴδετε ὅτι πόσον δίκαιός ἐστι cf. γράψον μοι ὅτι ποῦ εὕρισκομεν P. Oxy. 1671, 22. τοῦ + infinitive after πείθω is hardly a consecutive use; it should be classed with the same usage after verbs of desiring and attempting. On the substantivizing force of the article cf. χωρὶς τοῦ τὰ διομολογημένα CPR 4, 27; διὰ τὸ ἐμὲ μετρίως ἔχοντα P. Lips. 108, 5, etc.

P. W. HARSH, *Cl. Phil.* 32, 44–58, in dealing with *angiportum*, *platea*, and *vicus*, deals incidentally with *στενωπός*, *ἄμφοδον*, *λαύρα*, *ρύμη στενή*, *τυφλή ρύμη*. The Gk. masculines in circumflexed -ās are discussed by W. PETERSEN, *ibid.*, 121–30. The suffix from small beginnings in the classical period 'spread out until in a possessive sense it has become one of the commonest suffixes in modern Gk. It commonly designates (1) the male person in possession of a thing, e.g. ἄμπελās; (2) the possessor of a bodily or mental characteristic, e.g. κεφαλās "fathead"; (3) the maker or seller of something, a special case of (1), e.g. γαλατās "milkman".' The same author (*ibid.*, 305–28) contributes a study of the Greek place-names in -(ε)ών. To the names for parts of a house we should, I think, add the new word ὑπερών; we have the dative of this contracted form of ὑπερῶν in P. Fay. 95, 12, where the edd. print ὑπερωσι without any accentuation. H. C. YOUTIE (*ibid.*, 155–8) shows convincingly that the ἔχονομα of P. Oxy. 1160, etc., is a colloquial corruption of the adverb ἐχόμενα meaning 'next to, close to'. The same author (*ibid.*, 368–9) quotes a parallel for the σαμβάθῳ of P. Oxy. 903, 19. P. CHANTRAINE, in *Rev. ét. lat.* 15, 88–91, discusses Latin loan-words in late Gk., and shows how such words revived moribund native suffixes such as -τωρ. Of general linguistic surveys which contain chapters on the Koinē I have not seen the work of P. S. COSTAS, *An Outline of the History of the Greek Language: with particular emphasis on the Koine and the subsequent periods* (Chicago, Ukrainian Academy of Sciences of America, 1936). A. SEMENOV's book, *The Greek Language in its Evolution: an Introduction to its Scientific Study* (New York, Macmillan, 1936), does not inspire confidence. S. E. JOHNSON, in *J. Bibl. Lit.* 56, 331–45, suggests an approach to the problem of Semitisms in the New Testament and cites papp.

9. General Works, Bibliography, General Notes on Papyrus Texts

A. GENERAL

Papyrology: its contributions and problems (the Henry Russel Lecture, delivered May 14, 1936), by J. G. WINTER, printed in *Michigan Alumnus Quarterly Rev.* 42 (Summer, 1936, No. 23), 234–48, is excellent as a brief popular survey.

A lengthy art. on *Papyrus*, packed as usual with vast stores of refs., is contributed by H. LECLERCQ to the *Dict. arch. chrét.*, XII, 1, coll. 1370–1520. Though rather uneven and arbitrary in plan and treatment, it is well worth reading; sections on the manufacture of pap. in its technical and commercial aspects are followed by a goodly array of typical Christian texts on pap., printed in full, with translns. and nn.—amulets, prayers, liturgies, homilies, libelli, church inventories, Christian letters, the *Logia*, and so forth. Then come, rather out of place, sections on the papp. of W. Europe, such as the Ravenna deeds and papal bulls on pap. This part of the article is exceptionally full, more so indeed than the corresponding chap. in PREISENDANZ's *Papyrusfunde u. Papyrusforschung* (which, by the way, should have been referred to). We then return to Eg. with sections on Jews and anti-Semitism (the bibliography of BELL's *Jews and Christians* alone runs to almost 3 columns!), brief nn. on the Mani papp., complete transcrs. of the new Gospel fragmm. in the BM, and a short list of the contents of the Chester Beatty papp. Christian music is almost confined to discussion of P. Oxy. 1786 (5½ columns). Finally comes a vast bibliography, consisting of (1) a complete list of all publns. of papp. before 1900, and (2) a list of publns. of specifically Christian papp. from that date down to about 1936.

A comprehensive list of school exercises from Egypt, including papp., ostr., and wooden tablets, has

been compiled by P. COLLART, *Les Papyrus scolaires, Mém. Desrousseaux*, 69–80. Its 177 items are classified under different heads, Alphabets, Writing copies, Grammatical pieces, Homer, Mathematics, etc.; the whole should be invaluable for future editors of papp.

A masterly survey of Latin papp. from the pen of U. WILCKEN, *Über den Nutzen d. lateinischen Papyri*, is publ. in *Atti IV Congr. Int. Pap.*, 101–22. Originally delivered as a paper at the Florence Congress (the subject was suggested to him by VIFELLI) it now reappears fully equipped with footnotes and refs., which the wide dispersion of the material makes extremely valuable. After touching on the value of Latin papp. for our knowledge of palaeography, diplomatic, Latin literature, and Roman law, WILCKEN traces the vicissitudes of Latin as an official language in Eg. from Augustus to Justinian, as exemplified by the docs. themselves.

E. SEIDL's work as liaison officer between dem. and Gk. papyrology gives a special value to his paper at the Oxford Papyrological Congress, *Demotische Urkundenlehre nach d. frühptol. Texten*, now printed as *Münch. Beitr.* 27 (58 pp.). He analyses the types of dem. papp. from Alexander's conquest to the death of Ptolemy Philadelphus, traces the mutual influence (if any) of Gk. and dem. forms, and concludes with a chronological table of the 144 papp. from the period in question.

Some useful accounts of collections of papp. and the progress made with their publ. have recently appeared. KARL KALBFLEISCH, *Aus den Giessener Papyrussammlungen III, Nachr. d. Giessener Hochschulgeseilschaft*, xi. 3, pp. 1–8 (of offprint), gives a pleasant semi-popular account of recent Giessen publns., and announces that the next volume, which will appear very shortly, is to be *Griechische Wirtschaftsrechnungen u. Verwandtes*, by JOHANN HUMMEL (= P. Jand. viii). The remaining volumes of the Janda series will be: Heft 9, *Griechische Rechtsurkunden*, by KALBFLEISCH with assistance from E. KIESLING (in preparation); Heft 10, *Verschiedenes*; Heft 11, *Ostraka Iandana*; Heft 12, *Addenda, Corrigenda*, and *Indices* (in preparation). In the series *Mitteilungen aus d. Papyrussammlung d. Giessener Universitätsbibliothek* the following vols. are projected: Heft 5, *Alexandrinische Gerasia-Akten*, by A. VON PREMERSTEIN (promised for 1937, but I have not yet seen it); Heft 6, *Griechische Verwaltungsurkunden aus Tebtynis aus d. Anfang d. dritten Jahrhunderts n. Chr.* (reported as ready for press); Heft 7, *Rechtsurkunden*; Heft 8, *Verwaltungsurkunden, Wirtschaftsrechnungen u. Verwandtes*; Heft 9, *Verschiedenes*; Heft 10, *Addenda, Corrigenda, Indices* (in preparation).

P. COLLART gives an excellent account of *Les Papyrus inédits de la Faculté des lettres de Paris*, in *Atti IV Congr. Int. Pap.*, 69–75. This institution possesses (1) a large quantity of Ptol. cartonnage excavated by LEFEBVRE and JOUGUET at Ghorân and other sites in 1900–1902 and to be publ. by JOUGUET; (2) the Reinach collection, including unpublished papp. sufficient for several volumes, two of which are in preparation at the moment, *viz.* carbonized fragmm. from Thmuis, to be publ. by ANDRÉ BATAILLE, and a vol. of miscellaneous texts, both literary and documentary, undertaken by the Institut de Papyrologie. The *résumé* of the contents of this latter vol. sounds most attractive; (3) The Weill collection, shortly to be publ. by COLLART and Mlle ROUILLARD. HANS GERSTINGER, *Bericht über d. derzeitigen Stand d. Arbeiten an d. Papyrus Erzherzog Rainer*, in *Atti IV Congr. Int. Pap.*, 305–12, describes the contents of Heft 3 of the *Mitteilungen aus d. Wiener Papyrussammlung*, which will complete the publication of the non-Christian literary papp. Much work has already been done on the Christian texts, including some important fragmm. of Origen. It is hoped to continue the publ. of non-literary papp. in the CPR, and reference is made to some of the more interesting docs. now being studied. Heft 4 of the *Mitteilungen* will contain Hebrew and Aramaic texts, edited by A. Z. SCHWARZ. Unfortunately, now as in the past, economic difficulties are the chief obstacle to the progress of the work.

J. E. POWELL, *I Papiri greci Rendel Harris*, *Atti IV Congr. Int. Pap.*, 23–5, has been overtaken by the publ. it foreshadowed, *The Rendel Harris Papyri* (*JEA* 23, 89).

Another popular account (cf. *JEA* 23, 104) of the various papyrological collections in the Rylands Library is to be found in *Bull. Ryl. Libr.* 21, 298–302.

G. MANTEUFFEL, *Die neue Warschauer Ostrakasammlung*, has been noticed under § 3 above.

I have not seen EVARISTO BRECCIA, *Das römische Ägypten, Die Antike* 13, 61–76, which is said to be translated from an article in an Italian journal; the same author's *Egitto greco e romano* (Nuova Collezione, III), Naples, Loffredo [1936], is likewise inaccessible to me.

KARL KERÉNYI discusses from a psychological point of view the attitude of different ancient civilizations towards book-learning, and stresses the importance of papp. as illustrating the revolution in outlook wrought by Alexandrine scholarship: *Die Papyri u. d. Wesen d. alexandrinischen Kultur, Atti IV Congr. Int. Pap.*, 27–37.

B. BIBLIOGRAPHY

The following bibliographies are continued:

P. COLLART, *Bulletin Papyrologique*, xv (1935), *Rev. ét. gr.* 49 (1936), 501–35.

M. HOMBERT, CL. PRÉAUX, and others: *Bibliographie papyrologique* in *Chron. d'Ég.* 12, 101–25, 265–302.

A. CALDERINI, *Bibliografia metodica*, *Aeg.* 17, 129–94, 304–19; *Testi recentemente pubblicati*, *Aeg.* 16 (1936), 306–40; 17, 104–8, 283–4.

U. WILCKEN, *Urkunden-Referat*, *Archiv* 12, 218–47.

C. C. EDGAR, *Papyri*, in *The Year's Work in Classical Studies*, 99–105.

C. GENERAL NOTES ON PAPYRUS TEXTS

S. EITREM, *Varia*, Nos. 79–85, in *Symb. Oslo.* 17, 103–6, contains a number of excellent suggestions for the reading or interpretation of passages in publ. papp.

J. C. NABER, *Ad Octavianas 'Evreúξεις quasdam*, *Arch. hist. dr. or.* 1, 239–48, is inaccessible to me.

G. MICKWITZ has something to say on the use of gold and silver coins as bullion in *New papyri of numismatic interest*, *Num. Chron.* 17, 141–3 (on P. Brem. 83 and P. Harr. 97).

The section *Aggiunte, correzioni, riedizioni di papiri e di ostraca* is to be found in *Aeg.* 16 (1936), 341; 17, 109–10; 17, 285 (the last-mentioned consists of the publ. of a new fragm. of P. Lond. 1917 by T. C. SKEAT).

10. Miscellaneous, Excavations, Personal

The proceedings of the Fourth Papyrological Congress have appeared in a volume dedicated to the memory of VITELLI: *Atti del IV Congresso Internazionale di Papirologia. Firenze, 28 Aprile—2 Maggio 1935*. Pubblicazioni di 'Aegyptus'. Serie Scientifica: vol. v. Milan, 1936. xxv+496 pp. Price L. 100. Containing 39 papers by authors from 14 different countries, it well illustrates the international character of papyrology, and a commendably large number of contributors either give reports on papyrological work in progress or projected, or discuss questions of general and topical interest. A. CALDERINI, *Problemi di organizzazione e di divulgazione di Papirologia* (351–8), makes some valuable suggestions for editors of papp.; these include (1) a plea for uniformity in presentation of the material (including the novel but attractive proposal that the general conclusions drawn from the doc. should be placed at the end and not, as is now customary, embodied in the introduction); (2) more facsimiles, where possible alongside the text; (3) a standard nomenclature for the titles given to documentary papp.; (4) closer agreement on the abbreviations used to indicate different editions of papp. (a deplorable instance of ambiguity in this matter is provided by VOGLIANO's new *Papiri Milanesi*, so entitled regardless of CALDERINI's own publ. of the same name, for which 'P. Mil.' is the accepted abbreviation since 1928); (5) a *Berichtigungsliste* issued on cards at regular intervals, each card containing, under the name of the pap. concerned, the particular correction, comment, or re-edition to be noted. The final paragraphs discuss methods of popularizing papyrology by lectures, popular arts., publns. of select texts, etc. H. A. SANDERS, *Some Publns. in course of preparation by American Papyrologists* (469–71), deals with the work of Michigan scholars. All the publns. described have since appeared, except for the second vol. of Tebtunis papp., now being prepared by A. E. R. BOAK and MRS. E. HUSSELMAN. A valuable paper by A. MIOLATI, L. AMATI, and C. BOCCA, *Di un nuovo metodo applicato alla fotografia di 'Ostraka'* (77–83, with 4 figs.), describes various experiments with ostr. from which the writing had practically disappeared through rubbing and disintegration. Ordinary ultra-violet and infra-red photography were alike unsuccessful, but remarkable results were obtained by impregnating the ostr. in a fluorescent solution (a preparation of alder bark), illuminating it with ultra-violet light, and photographing with an infra-red filter and infra-red sensitive plates.

The Fifth Papyrological Congress was held at Oxford from 30 Aug.–3 Sept. 1937. The list of members exceeded 170, and over 60 papers were read, the majority of which, thanks to the timely intervention of M. HOMBERT, are shortly to be publ. in book form by the Belgian Fondation Égyptologique Reine Élisabeth. Reports on the Congress so far to hand include a charmingly-worded appreciation by W. OTTO, *Zum heutigen Stand d. Papyrusforschung: der fünfte internationale Papyrologen-Kongress zu Oxford*, in *Hist. Z.* 157, 309–18, and notes in *Cl. Rev.* 51, 161, and *Aeg.* 17, 124–8.

C. ANTI, *Scavi di Tebtynis (1930–1935)*, *Atti IV Congr. Int. Pap.*, 473–8, gives a summary account of the excavations, particularly of the Temple of Suchos. A. VOGLIANO, *Gli scavi della Missione Archeologica Milanese a Tebtynis, ibid.*, 485–96, actually describes his work at Medinet Mādi, and reprints the text of the

lengthy invocations to Isis inscribed on the walls of the temple of Amenemmes III after its restoration in the time of Ptolemy Soter II; though these effusions are of some interest from the standpoint of religious history, in poverty of thought and faultiness of metre they almost foreshadow Dioscorus! So far as papp. are concerned, nothing like the Mani codices has yet rewarded the excavators, though VOGLIANO was fortunate enough to pick up some scraps of Callimachus in Medinet el-Fayyūm. On Medinet Māḍi see also the report of the Antiq. Dept. in *Chron. d'Ég.* 12, 55-7.

The Franco-Polish excavations at Edfu have brought to light, among other remains of the Ptol., Rom., Byzantine, and Arab periods, a remarkable group of about 200 ostrr. relating to a Jewish family settled there; many are receipts for the Jew-tax, the Ἰουδαίων τέλοςμα, on which they shed valuable light. Cf. K. MICHAŁOWSKI, *Neue Funde in Edfu, Forsch. u. Fortschr.* 13, 273-5, and the report by B. BRUYÈRE in *Chron. d'Ég.* 12, 185-9.

E. BRECCIA surveys the past, present, and future of digging for papp. in *Dove e come si trovano i papiri in Egitto, Aeg.* 16 (1936), 296-305. He points out that the *kimān* of the Graeco-Rom. period are now practically worked out, except where there are modern towns on top (e.g. Kōm Ishgau); of the uninhabited *kimān*, only Dimai, Medinet Māḍi, and Antinoe offer any real prospect of papp., though of course there is always the possibility of chance finds in the most unlikely place.

N. FESTA writes a *Commemorazione di Girolamo Vitelli* in *Rend. R. Ist.* 6 (1936), 267-83. An obituary of OTTO GRADENWITZ by E. ALBERTARIO appears in *St. et Doc.* 1 (1936), while H. LIETZMANN contributes an appreciation, *Adolf Deissmann zum Gedächtnis*, to *Z. f. neut. Wiss.* 35 (1936), 299-306.

BIBLIOGRAPHY: CHRISTIAN EGYPT (1937)

BY DE LACY O'LEARY, D.D.

I. BIBLICAL

A. BÖHLIG, *Untersuchungen ü. d. kopt. Proverbientexte* . . . (*JEA* 23, 110) has been revd. by W. TILL in *WZKM* 44, 289–90, and by J. SIMON in *Biblica* 18, 354–6.

W. H. P. HATCH, *The Subscription in the Chester Beatty Manuscript of the Harclean Gospels*, in *Harv. Theol. Rev.* 30, 141–55, refers to the monastery of τὸ Ἐβαρον outside Alexandria, where Thomas of Harqel revised the Syr. gospels, in this subscription called Der' of Ἀντῦνῖνῦ (*i.e.*, following the rule of Antony), which may, however, be pointed Der' of Ἐνατῦνῖονῦ (*i.e.* Ἐβαρον), denoting the 'convent of the Enatonians', which H. thinks the more probable. Neither Ἐνατωνῖνοι nor Ἐβαρωνῖνοι occurs in Greek.

J. L. KOOLE, *Studien z. koptischen Bibeltext* . . . (*JEA* 22, 94; 23, 110) is revd. by W. TILL in *WZKM* 44, 291–2, and has also a very brief not. by S. GASELEE in *JTS* 38, 70.

W. TILL, *Säidische Fragmente d. Alten Testaments* appears in *Muséon* 50, 175–238.

The 'Abna l-Kanisah' edn. of the New Testament (*JEA* 21, 108; 22, 94; 23, 111) is revd. (together with the Euchologion) by O. H. E. BURMESTER in *JTS* 38, 196–9.

F. G. KENYON, *The Chester Beatty Biblical Papyri* . . . (*JEA* 23, 110) has added fasc. VI (Isaiah, Jeremiah, Ecclesiasticus), xiv+32 pp. Earlier parts are revd. by K. LAKE in *J. Bibl. Lit.* 58 (1936), 244–5, and by L. CERFAUX in *Rev. d'hist. eccl.* 33, 72–5, 541–2. As C. points out, the text contains no very unusual reading. The three pp. at the end of the preface 'recueillent les leçons du papyrus qui, à l'avis de l'éditeur, méritent une attention spéciale' (p. 75), and to these the revr. adds a series of others which also merit attention. Here must be noted the art. on *The Nature of the Text of the Chester Beatty Papyrus in Acts*, by R. V. G. TASKER in *JTS* 38, 383–95. 'We have in fact here a text not unlike that of the Caesarean text in the Gospels, a text which is mainly but not solely the text of the great uncials \aleph B, for it has a blend of readings of which some are found also in D.' (p. 393). Ref. should also be made to FR. W. BEARE, *The Chester Beatty Biblical Papyri*, in *Chron. d'Ég.* 12, 81–91.

H. I. BELL and T. C. SKEAT, *New Gospel Fragments* (1935), 33 pp., is revd. by HOMBERT in *Chron. d'Ég.* 11 (1936), 180, by HUBY in *Rech. sc. rel.* 26 (1936), 469–70, by BENOIT in *Rev. Bibl.* 45 (1936), 272–3, and by an anonymous writer in *Exp. Times* 47 (1936), 208–9.

H. I. BELL and T. C. SKEAT, *Fragments of an Unknown Gospel* . . . (*JEA* 22, 94) is revd. by H. A. SANDERS in *Cl. Phil.* 32, 163–4. Earlier revs. are by J. BEHM in *OLZ* 39 (1936), 613–16, by COLWELL in *J. Rel.* 16 (1936), 478–80, and by SCHMIDT and JEREMIAS in *Theol. Blätter* for Feb. 1936, 34. Here also should be noted L. CERFAUX, *Parallèles canoniques et extra-canoniques de l'évangile inconnu*, in *Muséon* 49 (1936), 55–77.

H. A. SANDERS, *A Third-century Papyrus Codex of the Epistles of Paul* . . . (*JEA* 22, 94) is revd. by E. C. COLWELL in *Cl. Phil.* 32, 385–7. C. considers that 'Professor Sanders' evaluation of the text is none too clear, nor is it very convincing' (p. 327), and that 'Those interested in the NT text should supplement their study of Sanders's careful publ. of this pap. by a study of Lietzmann's brilliant explanation of its significance' (*ibid.*); also by H. v. SODEN in *Gnomon* 13, 43–54, and by R. P. BENOIT in *Rev. Bibl.* 46, 58–82. This last deals with the varr. and gives critical nn.; some of the defects are due to a hasty copyist. H. HOSKIER, *A Study in the Chester Beatty Codex of the Pauline Epistles*, in *JTS* 38, 148–63, throws a good deal of light on the problems involved in this interesting text. The date seems to be not later than A.D. 200, and this puts back the date of the basic form of the Cop. version much earlier than has been hitherto assumed. 'The underlying sympathy ranges rather more with the base of the Boh. than with that of the Sah.' (p. 149). There is very little evidence of a Cop. reaction on the Gk. There is an earlier not. of the Beatty-Michigan Pauline pap. by W. KENNETH CLARK in *J. Bibl. Lit.* 55 (1936), 83–4. The leading study on this pap., W. LIETZMANN, *Zur Würdigung d. Chester Beatty Papyrus d. Paulusbrieife* . . . (*JEA* 21, 108) is discussed by L. CERFAUX in *Muséon* 50, 160–6.

C. H. ROBERTS, *Two Biblical Papyri in the John Rylands* . . . (*JEA* 23, 110) is revd. by F. W. BEARE in *Chron. d'Ég.* 12, 101–2, by M. L. D. in *Rev. Bibl.* 46, 141–5, and by L. CERFAUX in *Rev. d'hist. eccl.* 33, 70–2.

2. APOCRYPHAL, MANICHAEAN

(a) *Apocrypha.*

C. SCHMIDT and W. SCHUBART, *Πράξεις Παύλου* (*JEA* 23, 111) is revd. by J. SCHNEIDER in *DLZ* 58, 947–50, by ST. LÖSCH in *Zeitschr. f. bibl. Wiss.* 54, 302–3, by E. HENNECKE in *TLZ* 62, 199–201, by H. I. BELL in *JTS* 38, 189–91, who suggests several emendations (p. 191), by B. ALTANER in *Theol. Rev.* 36, 10–12, by L. CERFAUX in *Muséon* 50, 161–2, and by F. HALKIN in *An. Boll.* 55, 354–7, who notes: ‘On se rappellera que, dès 1904, en publiant les fragments du papyrus d’Heidelberg (BHO 882) il (*i.e.* Prof. C. Schmidt) avait énoncé cette thèse surprenante que les trois apocryphes pauliniens dont l’antiquité est incontestable: la légende de Ste Thècle, la correspondance supposée de l’Apôtre avec les Corinthiens, enfin son martyre, n’étaient que des morceaux détachés d’une grande composition intitulée *Πράξεις Παύλου*. De cet ouvrage considérable, aucune trace n’avait survécu en grec: seuls les fragments coptes permettaient à M.S. de le reconstituer idéalement’ (p. 355). The editor considers that the newly discovered material confirms his thesis; the revr. takes the opposite view.

(b) *Manichaeism.*

A. BÖHLIG, *Die Veröffentlichung d. Berliner koptischen Mani-Texte* appears in *Forsch. u. Fortschr.* 13, 263–4, and emphasizes the importance of the *Kephalaia*.

C. SCHMIDT and A. BÖHLIG, *Manichäische Handschriften d. Staatlichen Museen, Berlin, I: Kephalaia*, Stuttgart (1935) . . . (*JEA* 21, 109; 22, 95; 23, 111) is revd. by W. TILL in *WZKM* 44, 290–1. New fasc. (Nos. 7, 8, pp. 148–94) have appeared.

H. POLOTSKY and H. IBSCHER, *Manichäische Homilien* . . . (*JEA* 20, 207) was revd. by O. KRÜCHMANN in *Z. f. Kirchengesch.* 55 (1936), 678–83.

H. H. SCHAEDEER, *Manichäismus nach neuen Funden u. Forschungen*, in *Orientalische Stimmen z. Erlösungsgedanken* (Morgenland, 28), Leipzig, 1936, 80–109.

3. LITURGICAL

P. V. B. contributes *Il rito copto e la sua liturgia* to *La voce del Nilo* 6, 51–3, 80–2, 102–4, 120–1.

O. H. E. BURMESTER, *The Tūruhāt of the Cop. Church* is a contribution to *Or. Chr. Per.* 3, 78–100.

The Cop. Euchologion of the ‘Abna l-Kanisah’ (*JEA* 23, 112) is revd. by J. SIMON in *Orientalia* 7 (1936), 112–17, with corrigenda and bibliographical refs. for the convenience of liturgical students. It is also revd. (with the same Society’s edn. of the NT) by O. H. E. BURMESTER in *JTS* 38, 196–9.

G. GRAF, *Das Fest Kreuzerhöhung in d. orientalischen Riten*, in *Der Christliche Orient in Vergangenheit u. Gegenwart*, 2, 98–101, deals with the feast observed on 17th Tout (= 14th Sept.).

4. LITERATURE

J. B. BERNHARDIN, *A Cop. Sermon attributed to St. Athanasius* appears in *JTS* 38, 113–29. In the same periodical R. H. CONNOLLY contributes two arts., *Barnabas and the Didache*, *ibid.*, 167–8, and *Canon Streeter on the Didache*, *ibid.*, 364–79.

J. LEBON, *Le Pseudo-Basile (Adv. Eunom., iv. v) est bien Didyme d’Alexandrie* appears in *Muséon* 50, 61–84.

TOGO MINA, *Jules d’Aqfahs et ses œuvres, à propos d’une icône conservée dans l’église d’Abou ’s-Seifein* is publ. in *Bull. Ass. am. art copte* 3, 41. The list of works given in this ikon differs from that ascribed to the author of so many passions of Cop. martyrs: Julius is treated as a definitely historical character.

M. RICHARD, *Une Homélie de Théophile d’Alexandrie sur l’institution de l’Euchariste* is publ. in *Rev. d’hist. eccl.* 38, 46–56. The homily is that ascribed to Cyril of Alexandria in *PG* 79. 1016: it is an oration against the Origenists and can be dated 29 March 400.

BLAKE-DE VIS, *Epiphanius* . . . (*JEA* 22, 95; 23, 112) is revd. by W. HENGSTENBERG in *BZ* 37, 400–8, with a very full criticism of the Cop. material employed.

A. STEIDLE, *Patrologia seu historia antiquae litteraturae ecclesiasticae*, Freiburg i/B. xvii+294 pp., does not ignore Cop. literature, *e.g.* pp. 96–100, 143–4, 265.

M. JUGIE, *Theologia dogmatica, tom. V* . . . (*JEA* 13, 254; 23, 118) is revd. by R. DRAGUET in *Muséon* 50, 411, by the same author in *Rev. d’hist. eccl.* 33, 89–96, and by T. RIVIÈRE in *Rev. Sci. Rel.* 16 (1936), 419–21.

J. LEBON, *Les Anciens Symboles dans la définition de Chalcedoine* is publ. in *Rev. d’hist. eccl.* 32 (1936), 809–76.

C. A. BERNOULLI and L. FRÜCHTEL, *Klemens v. Alexandria. Die Teppiche* (Stromateis), Basel 1936, vii+776 pp., is a German transl. of the Stromateis. It is revd. by J. BEHM in *OLZ* 40, 525–6.

5. HISTORY

(a) Church History.

D. ATTWATER, *The Dissident Eastern Churches* (Religion and Culture Ser., ed. J. Husslein), Milwaukee, xviii+349 pp., illustrs. (*JEA* 22, 95; 23, 113). Ch. xii deals with the Monophysite churches of the Alexandrian rite, (a) the Cop. Church, 239–50, and (b) the Ethiopian Church, 251–65. It covers the same ground as the late Dr. A. Fortescue's work, but gives several new items and is more popular in character.

G. BARDY is the author of two studies in the hist. of the Alexandrian Church: *Aux origines de l'école d'Alexandrie* in *Rev. Sci. Rel.* 27, 65–90, and *La Rivalité d'Alexandrie et de Constantinople au v^e siècle*, in *Rech. de théol. philos. hist.* 19 (1936), 5–19.

L. BREHIER contributes an art. on Blemmyes (*Βλέμμυες* ou *Βλέμυες*) to the *Dict. d'hist. et de géogr. eccl.* ix, 183–5.

A work of striking interest, though not primarily concerned with Cop. or Christian material, is FR. CUMONT, *L'Égypte des Astrologues*, Brussels (Fond. Égyptol. Reine Élisabeth), 254 pp. Sect. 11 incidentally deals with the much debated problem of the *κάτοχοι*, whom the writer regards as undesirables, consecrated in the sanctuary and not allowed to leave the precincts, a view which is not altogether novel. Sect. 12 deals with Gnosis and divination, Sect. 13 with magic.

A. N. DIAMANTOPULOS, 'Η τετάρτη Οικουμενική Σύνοδος ἐν χαλκηδόνι, 451, appears in *Θεολογία* 14 (1936), 208–24, 297–309.

S. GASELEE, *The Copts*, in *J. Roy. Cent. Asiatic Soc.* 24, 27–45, is an interesting art. which lays emphasis upon the artistic work of the Copts. The same writer's *The Roman Catholic Communion*, (b) *Uniat* (Union of Christendom, International Convention, 1940. The Present Grouping of Christendom. Sect. III. i. b), London (N.D.), 15, gives attention to the Copts and Ethiopians (pp. 9–11). FR. HEILER, *Urkirche und Ostkirche*, München, xx+607 pp., includes 'Die koptische Kirche' (pp. 471–91) and 'Die äthiopische Kirche' (pp. 492–510). R. JANIN, *Les Églises orientales et les rites* is appreciatively revd. in the *Eastern Churches Quart.* 2, 51.

Mgr. MARC KHOUZAM, *Missions des coptes catholiques en Égypte*, Cairo, 21 pp., 11 illustrs., and English transln. as *Missions in Egypt of the Catholic Copts*, Cairo, 21 pp., 11 illustrs., is a popular work by the Uniat Bishop of Thebes and deals with the hist. and present state of the Cop. Uniat Church.

Less easily classified is E. LAUZIERE, *L'Âme copte*, in *Le Rayon*, Cairo, 1936, 241–5.

G. LAZZATI, *Teofilo d'Alessandria* . . . (*JEA* 22, 111) is revd. by KL. JÜSSEN in *Theol. Rev.* 36, 228–9, and by P. CH. BAUR in *BZ* 37, 150–1.

R. MOND and C. H. MYERS, *The Bucheum*, London, 1934, 3 vols., is revd. by CH. MARTIN in *Rev. d'hist. eccl.* 34, 428, and by L. P. K. in *Antiquaries' Journ.* 1937, 92–4, the latter rev. pointing out the important evidence it contains as to the survival of paganism in Eg. after Constantine.

J. SIMON, *L'Inventaire des monuments de la Bible médiévale*, in *Orientalia* 6, 360–79, directs attention to U. MONNERET DE VILLARD's *La Nubia medioevale* (*JEA* 22, 99).

G. SOTTOCHIESA, *La religione in Etiopia* is publ. in *Quaderni nazionali*, 3a ser., 1, Turin, 1936, 208 pp., 6 pls.

D. O'LEARY, *The Ethiopian Church* . . . (*JEA* 23, 113) is revd. by H. DUENSING in *TLZ* 63, 178–9.

J. R. PALANQUE, G. BARDY, P. DE LABRIOLLE, *De la paix constantinienne* . . . (*JEA* 23, 113) is revd. by J. SIMON in *La Terre Wallonne* 35 (1936), 314–16, and by J. LEBON in *Rev. d'hist. eccl.* 33, 85–7, the revr. pointing out certain dubious statements (pp. 86–7). The new publ. in the same series is vol. IV, P. DE LABRIOLLE, G. BARDY, L. BREHIER, G. DE PLINVAL, *De la mort de Théodose à l'élection de Grégoire le Grand*, Paris, 612 pp., a period of great moment in the hist. of the Church, and especially of the eastern and Cop. communions. It is favourably revd. by J. LEBON in *Rev. d'hist. eccl.* 33, 809–11, though the revr. takes exception to some statements—the description of Dioscorus I's doctrine as purely Eutychian (p. 425) and certain other points, mostly those concerning the Eastern and Egn. branches of the church. The revr. considers that the book has been too much influenced by Maspero's (unfinished) work. It is also revd. by J. SIMON in *La Terre Wallonne* 36, 71–3.

O. W. REINMUTH, *The Prefect of Egypt from Augustus to Diocletian*, Leipzig, 1935, xiv+155 pp. (*Klio* 34, N.F., Heft 21), is not directly concerned with Christian life, but indirectly the office and functions of the prefect illustrate the circumstances of the trials of the martyrs. Revd. by F. EGERTON in *Cl. Phil.* 32, 182–3.

H. GAUTHIER, *Les Nomes d'Égypte depuis Hérodote à la conquête arabe* (*Mém. Inst. d'Ég.*, xxv), Cairo (1935), xxiii+219 pp., 5 pls., connects the nomes with Cop. dioceses. It is revd. by B. V(AN) D(E) W(ALLE) in *Chron. d'Ég.* 10 (1935), 403–5, and by A. ADRIANI in *Bull. Soc. arch. d'Alex.* 30 (1936), 142–3.

SCHWARTZ, *Acta Concil. Univ. Chalced.* . . . (*JEA* 23, 113) is revd. by F. DIEKAMP in *Theol. Rev.* 36, 146-9.

H. PÉLISSIER, *Églises coptes d'Égypte (1880-1935)* (*Xaveriana*, 145), Louvain, 1936, 36 pp.

(b) *Hagiology.*

O. H. E. BURMESTER has published *The Date of the Transln. of Saint Ischirin in Muséon* 50, 33-60.

K. DOWERTIL, *Severos v. Alexandria*, in *Byz.-neugr. Jahrb.* 30, 5-16, deals with the sixth-cent. Alexandrian writer.

K. ENGBERDING, *Pachomius d. Ältere* is an art. in the *Lex. f. Theol. u. Kirche*, VII (1935), 860-1, and the same writer's *Schenute* appears *op. cit.*, IX, 243.

H. LECLERCQ, *Paphnuce* is an art. in the *Dict. arch. chrét.*, XIII, cols. 1358-61.

TOGO MINA, *Le Martyre d'Apa Epima (Serv. des Antiquités de l'Égypte)*, Cairo, xxxii+125 pp., gives the martyrdom from a Pierpont Morgan codex. J. MUYSER, *Le Samedi et le Dimanche dans l'Église et la littérature coptes*, forms pp. 89-111 of this work.

D. O'LEARY, *The Saints of Egypt*, London, 286 pp., is a popular account of the saints commemorated in the Synaxarium of the Cop. Church.

W. TILL, *Kopt. Heiligen-* . . . (*JEA* 21, 111; 23, 114) was revd. by A. BÖHLIG in *DLZ* 57 (1936), 572-5.

ST. BINON, *Essai sur le cycle de Saint Mercure, martyr de Dèce et meurtrier de l'empereur Julien (Bibl. de l'École des Hautes Ét. Sciences Religieuses, LIII)*, Paris, vii+144 pp., 1 illust. An excellent monograph in which special ref. is made to the cult of St. Mercury in Cop. churches, according to the literary tradition (pp. 59-69), liturgical tradition (pp. 102-5), and iconography (pp. 128-9).

(c) *Monasticism.*

K. HEUSSI, *Der Ursprung d. Mönchtums* . . . (*JEA* 23, 114) is revd. by J. SIMON in *Orientalia*, 6, 302-3, by C. JENKINS in *JTS* 38, 290-1, by L. HAUSER in *Or. Chr. Per.* 3, 296-9, and by L. TH. LEFORT in *Rev. d'hist. eccl.* 33, 341-8, a rev. which in itself is a valuable essay on monastic origins and brings forward observations of vital importance. L. comments on the fact that H. confines himself to Gk. and Latin sources for the early Egn. ascetes, for St. Pakhom and Shenoute, for whom a good deal of Cop. material is available. It is revd. also by H. DÖRRIES in *TLZ* 62, 101-2, and by H. A. VAN BAKEL in *Nieuw Theol. Tijdschrift* 26, 398-9.

H. LECLERCQ, *Palladius* is an art. in the *Dict. arch. chrét.*, XIII, 912-20. W. TELFER is the author of an art. on *The Trustworthiness of Palladius* in *JTS* 38, 379-82.

J. SIMON, *Les Premiers Disciples de S. Amún au Wádi' n-Natrún* (in Arabic) is publ. in *Aṣ-Ṣalāḥ* 7, 444-6.

A. J. FESTUGÈRE, *Sur une nouvelle édition du 'De Vita Pythagorica' de Jamblique*, in *Rev. ét. gr.* 50, 470-94. The author shows analogies between this 'Life' and certain important docs. of Christian monachism, such as St. Athanasius's Life of St. Antony, the Life and Rule of St. Pakhom, the Lausiac History, and the Apophthegmata.

6. NON-LITERARY MATERIAL

P. COLLART, *À l'école avec les petits grecs d'Égypte*, in *Chron. d'Ég.* 11 (1936), 489-507, is a study of education according to the 'school-boy' papyri.

W. F. EDGERTON, *Medinet Habu Graffiti: Facsimiles* (Univ. of Chicago, Or. Inst. Publ. xxxvi), xii+6pp., 11 figs., 103 pls. Nos. 92-102 are Cop., the rest hierogl., hieratic, and dem.; almost all are badly damaged. Two pls. in colour represent scenes from the life of St. Menas. Translations are to follow later.

R. ENGELBACH, *Coptic Stela of Damshir*, in *Bull. Ass. am. art copte*, 3, 6-8, 1 pl., gives an inscr. (Sa.) in 19 lines in the Cairo Mus., in two different hands.

S. EITREM and L. AMUNDSEN, *Papp. Osloenses*, fasc. III (1936), xi+326 pp., 12 pls., contains 12 papp. of a literary or semi-literary character. Nos. 72-6 deal with medicine, astrology, magic, etc. Nearly all are of the Rom. period (1st-3rd cents.).

A. HEBBELYNCK and A. VAN LANTSCHOOT, *Codices coptici Vaticani*, Vatican City, xxxv+698 pp., is certainly the most important Cop. publ. of the year and has been long expected. The preliminary pp. (ix-xxxv) contain preface, hist. of the codices, rules followed in editing, and addenda and corrigenda. Then follows a description of the Boh. MSS. (1-694), followed by a classified index (695-8). The main numeration is still that of Mai, so that it is easy to find material from the older catalogues. The great vellum Nitrian codices (Nos. 57-69) containing Acta and homilies are described at length and the Gk. originals identified where possible, a most valuable feature. Every piece in the literary MSS. is minutely described, and its

incipit, explicit, and colophon are given. Vol. II (Sa.) is in the press, but is not likely to appear for some time. Vol. I is revd. by L. TH. LEFORT in *Muséon* 50, 162–3, and by J. LEBON (in *Rev. d'hist. eccl.* 33, 805–8), whose rev. contains an important comment: 'Je ne ferai de remarques que concernant un détail minime, l'assignation des dimensions des manuscrits. Il me semble que l'utilité principale de cette indication consiste en ce qu'elle peut contribuer à faire retrouver ailleurs des parties ou des feuillets de manuscrits mutilés. Mais le mesurage des feuillets dans leur état actuel est assez aléatoire, car certains d'entre eux peuvent avoir été rongés ou rognés. . . . Pour la valeur de critère de l'indication, ne vaudrait-il pas mieux signaler en millimètres les dimensions et l'espace couvert par l'écriture, donnée beaucoup plus uniforme et constante?' (807–8). It is revd. also by H. MUNIER in *Bull. Ass. am. art copte* 3, 75–6.

L. TH. LEFORT, *Coptica Lovaniensia* appears in *Muséon* 50, 5–52, with 3 pls. The MSS. included contain biblical fragmm. from Gn. 17–50, Ex. 1–22, Dt. 7–9. The pls. show Gn. 3, 2–7; 21, 32–22; Dt. 9, 28–10, 4.

H. KASE, JR., *Papp. in the Princetown Univ. Collection*, II, Princetown, 1936, xi+130 pp., 10 figs., contains a Gnostic fragm. (No. 107), a 'fever amulet' of the fourth–fifth cents.

H. J. POLOTSKY, *Zwei kopt. Liebeszauber*, in *Orientalia* 6, 119–31. From the evidence of two texts drawn from Wien Pap. K. 192 and Michigan Inv. 4932 the author deduces a hypothesis in the hist. of Christian dogma which is summarized by W. H(ENGSTENBERG) in *BZ* 37, 210.

E. SEIDL, *Der Eid im röm.-äg. Provinzialrecht*, II: *Die Zeit v. Beginn d. Regierung Diokletians bis z. Eroberung Ägyptens durch d. Araber*, *Münch. Beitr.*, No. 24, 1935, has a definite bearing upon Christianity as it shows the gradual modification of the form of oath under Christian influence. An appendix deals with the oath in Cop. law.

MUHAMMAD AHMAD SIMKAR, *Oriental Manuscripts of the John Frederick Lewis Collection in the Free Library of Philadelphia: A Descriptive Catalogue*, Philadelphia, xix+248 pp., 48 illusts. Amongst the MSS. described is one (No. 201) which is a Copto-Arabic lectionary of the thirteenth–fourteenth cents.

W. TILL, *Eine kopt. Bauernpraktik* (*JEA* 23, 113) is a rustic calendar or agricultural guide drawn from material in the collection of papp. in Vienna. It is publ. in *Mitt. deutsch. Inst. Kairo* 6 (1936), 108–50, 1 pl. It is the subject of a useful n. by W. H(ENGSTENBERG) in *BZ* 37, 189–90, and is revd. by L. TH. LEFORT in *Muséon* 50, 165.

J. G. WINTER, *Papp. in the Univ. of Michigan Collection*, III (Univ. of Michigan Studies. Humanistic Ser., XL), Ann Arbor, 1936, xviii+390 pp., 7 pls. This is revd. and commended by H. I. BELL in *JTS* 38, 417–18.

Bull. Ryl. Libr. 21, 298–302 refers (p. 299) to the Cop. papp. in the Rylands Library, Manchester. There are more than 500 pieces, mostly of the fourth–sixteenth cents. These were catalogued by W. E. Crum in 1909, and a supplementary catalogue was made by the same scholar in 1920.

7. PHILOLOGY

F. CALICE, *Grundlagen d. ägyptischsemitischen Wortvergleichung*, in *WZKM*, 1936, vii+278 pp., is revd. briefly by M. COHEN in *Bull. Soc. Linguistique*, Paris, 38, 170–1.

W. E. CRUM, *Coptic Dictionary*, Part v. ⲙⲁⲓⲏⲧⲉ-ϩⲱⲨⲏ , viii pp. and pp. 573–744 has appeared. A sixth part is to follow which will contain indices of Gk. words, etc.

H. J. POLOTSKY, *Deux Verbes auxiliaires méconnus du copte* appears in *C. R. des séances du groupe linguistique d'ét. chamito-sémitiques* 3, 1–3.

J. SIMON, *Wann starb d. Koptische aus?* in *ZDMG* 90 (1936), (44)–(45), is the résumé of a communication presented to the eighth Orientalistentag, Bonn, Sept. 1936.

A. ŚMIESZEK, *Notes on Egm. Accent as evidenced in Cop. Nouns* is publ. in *Poznańskie Towarzystwo Drzyciació nauk*, Poznań (1935), but I have not been able to see a copy. The same writer's *Some Hypotheses concerning the pre-history of the Cop. Vowels*, issued by Polska Akademia Umiejetności, Krakau, 1936, is revd. by W. TILL in *WZKM* 44, 288–9.

W. TILL, *Das Pi'el im Ägyptischen* appears in *ZÄS* 73, 131–8.

W. H. WORRELL, *Popular Traditions of the Cop. Language*, in *AJSL* 54, 1–11, is chiefly concerned with Cop. phonology; the old traditional pronunciation differs from the modern Gk. vocalization introduced in the nineteenth cent. The treatment is largely based on Dr. Vycichl's investigations in the Cop. community at Zeniyah.

In KENYON, *The Chester Beatty Biblical Papyri* . . . fasc. vi (p. 118 above), CRUM has a chapter dealing with the Old Coptic glosses in Isaiah, which are an important addition to our Old Coptic material.

8. ARCHAEOLOGY

(a) *Topography.*

N. ABBOT, *The Monasteries of the Fayyum* appeared in *AJSL* 53 (1936-7), 1-12, 73-96, and has been publ. separately, Chicago, 1937, 66 pp. It gives some tenth-cent. contracts dealing with the monasteries (in Arabic).

J. FAIVRE, S.J., *L'Église Saint-Sabas et le Martyrium de Saint-Marc à Alexandrie*, in the *Bull. Ass. am. art copte* 3, 59-74, is a collection of valuable studies whose earlier publ. was prevented by the war. The author died in 1919.

E. MÉRIAL, *Les Églises coptes du Vieux Caire* appeared in *Le Rayon*, Cairo, 1936, 237-9.

H. MUNIER, *Le Deir Abou-Lifa*, in the *Bull. Ass. am. art copte*, 3, 1-5, 2 illusts., describes a monastery east of one of the first heights of the Gebel Ḳatrāni in the north of the Fayyūm. Seven Cop. inscr. and one Arabic were found there. The same writer's *Le Monastère de Saint Abraham à Farshout*, in the *Bull. Soc. arch. d'Alex.* 9 (1936), 26-30, and his *Babylone d'Égypte* in *Le Rayon*, 1936, 228-9, are also deserving of note.

B. POERTNER, *Das Menasheiligtum in d. Wüste Mariut* appears in *Der Christliche Orient in Vergangenheit u. Gegenwart* 2, 43-50.

M. H. SIMAIKA PACHA, *Guide sommaire du Musée Copte et des principales églises du Caire*, Cairo, 94 pp., 161 pls., describes the various objects in the Cop. Museum—architectural fragments, wood carvings, ceramics and glass, textiles, metal objects, and ikons—then proceeds to describe fifteen of the principal churches of Cairo. It is the transl. of a guide publ. a few years ago in Arabic. It is revd. by H. M(UNIER) in the *Bull. Ass. am. art copte* 3, 77-8.

JOH. GEORG HERZOG ZU SACHSEN, *Neueste Streifzüge . . .* (*JEA* 17, 253) is revd. by VAN CUTSEM in *An. Boll.* 54 (1936), 181-2.

A. KAMMERER, *La Mer Rouge, l'Abyssinie et l'Afrique depuis l'antiquité*, t. 2 (*Mém. Soc. roy. de géogr. d'Égypte*), Cairo, 1935, xvi+555 pp., 169 pls., 95 figs. (2 vols.).

A. CALDERINI, *Dizionario . . .* (*JEA* 22, 99) is revd. by J. SIMON in *Orientalia* 6, 132-42, and by W. SCHUBART in *Gnomon* 12 (1936), 282-4.

(b) *Art.*

C. H. COSTIGAN, *Sculpture and Painting in Cop. Art*, in *Bull. Ass. am. art copte* 3, 48-58, points out the Egn. influence perceptible in Cop. art, as well as the Arab influence: its character was preserved to the ninth cent. It evolved normally until the fifth-sixth cents., then came a brusque change; scenes were simplified and reduced to two or three figures, geometrical patterns were introduced, akin to the Celtic. The two pls. show panels from the church of Abu Serga in Old Cairo.

E. DIAZ, *Kubba*, in the *Encycl. Islam*, suppl. No. 3, 127-34, 14 figs., has a bearing on Cop. architecture.

ÉT. DRIOTON, *Art syrien et art copte*, in *Bull. Ass. am. art copte* 3, 29-40, is a very full and instructive treatment of the two forms of art. The same writer's *L'Art copte* appeared in *Le Rayon*, Cairo, 1936, 234-6.

ZAKI MOHAMMAD HASAN, *بعض التأثيرات القبطية في الفنون الإسلامية*, also in the *Bull. Ass. am. art copte* 3, 104-83, is upon Cop. art, sculpture, embroidery, and painting.

U. MONNERET DE VILLARD, *Die Kuppelbasilike in Nubien*, in *Artibus Asiae* 6, 203-20, 13 figs., is an interesting n. on the basilicas with cupolas in Nubia and on the Asiatic origin of this type.

S. GUYER, *Abessinischer Kirchenbau* appears in *Die Christl. Kunst* 33 (1936), 80-8.

P. GRAINDOR, *Statue copte du Musée d'Alexandrie*, in *Bull. Inst. arch. bulgare* 10 (1936), 169-72.





H. LECLERCQ in CABROL-LECLERCQ: *Dict. arch. chrét.*, XIII, gives two arts. with bearing upon Cop. archaeol., *Papier* (cols. 1364-9), of which sect. II has special bearing on Egn. docs., and *Papyrus* (cols. 1370-1519), which gives a very extensive, if not exhaustive, list of extant papp. The previous vol., XII (1936), 2291-322, contained an art. on *Orant, Orante*, which gave special ref. to the use of these figures in Byzantine and Cop. art.

J. MUYSER, *Des vases eucharistiques en verre*, in *Bull. Ass. am. art copte* 3, 9-28, 1 pl., is a full and interesting account of the use of such vessels from Cop. and Arabic sources. The pl. represents a specimen in the Cop. Mus. of Old Cairo.

R. PFISTER, *Matériaux pour servir au classement des textiles ég. postérieurs à la conquête arabe* appears in *Rev. des arts asiatiques* 10, 1-16, 73-85, figs. 1-3, 28-32. It deals chiefly with material in the Arab Museum in Cairo. Two sections deal with Cop. Christian specimens, (1) late Cop. textiles with Christian designs, apparently of the seventh-ninth cents., and (2) materials from late Cop. costumes with ornamental fillets.



BRIEF COMMUNICATIONS

A Later Allusion to Akhenaten

It has long been recognized that the dating of certain judicial proceedings in the fifty-ninth year of Haremhab which is found in the record of a famous lawsuit under Ramesses II¹ can be explained only by the attribution to Haremhab of all the regnal years of Akhenaten and his ephemeral successors.² The execration in which the Aten heresy was held during the generations following its suppression would not tolerate even an implicit admission that the rulers in question had possessed legitimate claims to the throne, yet for legal purposes the need will sometimes have arisen to mention some specific date between the death of Amenophis III and the accession of Haremhab; for general purposes it will have sufficed to write 'in the times of the enemy of Akhet-aten', as is done in another passage of the afore-mentioned inscription. So far as I am aware no specific date of the kind has yet been noted, but one occurs in a very fragmentary papyrus, long in the possession of the Berlin Museum. This papyrus (Inv. 3040 A) contains the scanty remains of a long letter addressed by some one to the 'prince Pesiür', possibly the 'prince' or 'mayor' of Thebes, since the greetings name Müt and Khons as his 'good lords' and a miserably broken passage makes it obvious that he possessed authority to remit or alter the tax-assessment of a  'Ramese, prince of the West of Thebes'. This Pesiür can hardly be identical with the Vizier of that name who held office in the reigns of Sethos I and Ramesses II, though the style of writing and the orthography (note particularly the relative form  in place of later ) make it highly probable that the two were contemporaries. In ll. 6-7 of the *recto* I read as follows: 

 'Further, as to what you write to me asking that the day of . . . 's death should be sent to you, when one (i.e. Pharaoh?) arrived in Memphis, [the . . . came to me] to say that he died in year 9 of the Rebel'. It would be out of place to insist on minor difficulties of reading and translation, but I will observe that the words rendered 'the Rebel' could equally well be rendered 'the Rebellion'. In either case the reference must surely be to the reign of Akhenaten.

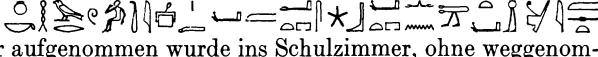

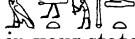



ALAN H. GARDINER.

The Idiom *it in*

IN ZÄS 73, 81 Kees translates the phrase  'Ich war ein Armer, der aufgenommen wurde ins Schulzimmer, ohne weggenommen zu werden, als er hineingebracht war; einer der hinsieht und es findet', thus ignoring the fact that, as his note shows, Grapow had made him partly aware of the idiomatic character of . Sethe long ago pointed out to me that this is 'an expression for disorderly movement with various nuances' (*JEA* 1, 104, n. 3) and *Wb.*, I, 149 (22) not quite happily sums up the meaning 'oft im Sinne von: unregelmässig sein u. ä'. It may be useful to suggest renderings for the various examples that have been quoted, and to classify them in some sort of order. I ignore, except by way of illustration, examples where the two verbs have each an object, or do not follow one another directly. These, however, seem to give the origin of the idiom as to take something to a place and then to bring it back, see especially Davies, *Five Theban Tombs*, Pl. 6; hence, in our English phrase, 'to chop and change', cf.  'Do not take a word and bring it back again', i.e. don't chop and change in your statements, parallel to 'do not put one thing in place of another',

¹ See Gardiner, *The Inscription of Mes.* 52.





² So comparatively recently E. Meyer, *Gesch. Alt.*,² II. 1, p. 413.

Ptahhotpe, 608–9. Here already we have our dichotomy of physical and psychical movement. Applying this we obtain: (1) PHYSICAL MOVEMENT: *P. Smith*, 3, 17  ‘without moving to and fro’, of stiffness of the ligaments of the jaw; *Urk.*, IV, 710, 12 ‘the army of His Majesty attacked  in a vacillating way (?)’; *Inscr. déd.*, 33 ‘the priesthood of the temple  was like (a woman) who moves to and fro before her fields,¹ when their boundaries have not been firmly fixed in the earth.’ (2) PSYCHICAL MOVEMENT: (a) in neutral or good sense, *Urk.*, IV, 365, 6, ‘my mind (lit. ‘heart’)  travelled this way and that imagining the words of the common people who should see my monument in years to come’; (b) in a pejorative sense *P. Petr. 1116 B*, vs. 37  ‘this land will waver and the issue that is to come will not be known’; so in epithets after *šw m*, *P. Ch. Beatty VIII*, rt., 9, 6,² ‘unwavering’, of Thoth; *Totb.*, ed. Nav., 160, 2, of the deceased; rather differently, Bergmann, *Hierogl. Inscr.*, 61, 3  ‘do not tamper (or juggle) with the corn-measure’; the Graeco-Roman exx. quoted by *Wb.* are obscure to me.



Even after this examination of examples the sentence from which we started is none too clear. It might be rendered physically, ‘I was a poor lad firmly planted³ in the school, not fidgeting in it’, but I am rather inclined, in view of the last clause, to take the whole psychically: ‘I was a poor lad well-grounded at school, unwavering in it, who had only to look for a thing in order to find it.’ The uncertainties of Egyptian translation are indeed deplorable.

ALAN H. GARDINER.

Sur un Nom du Wâdi Maghâra (Sinâï)

D’APRÈS plusieurs égyptologues, la région des mines de turquoise du Sinâï serait désignée par une expression *htyw (m)fkst rn.f* attestée par deux inscriptions du Wâdi Maghâra: (a) Sethe, *Urk.*, I (1933), 56,  A  B, C, D, . . . ; (β) *Id.*, *ib.*, 113,  A  B, C, D, . . . (A, B, C, D = titres et noms de personnes). Cette expression a été traduite: ‘le pays nommé les Échelles de la Turquoise’ (Weill, *Inscrip. du Sinâï*, 49–50, 113, 127, et *Sphinx* 8, 182), ‘la terrasse dont le nom est (m)fkst (turquoise)’ (Gauthier, *Dict. géog.*, VI, 150, et *Kémi* 2, 70), ‘the terrace, the name of which is “Malachite”’ (Breasted, *Anc. Rec.*, I, §§ 266, 342).

L’expression *r htyw mfkst rn.f* est suspecte en elle-même. Une phrase relative du type *X rn.f* peut difficilement être le complément d’une préposition;⁴ un nom signifiant ‘contrée’, ‘pays’, etc., devrait la précéder (ex.: *Urk.*, I, 136, 15). Si ce nom était sous-entendu, on devrait avoir *rn.š* au féminin (d’après Gardiner, *Eg. Gr.*, § 92, 1). On ne peut pas davantage faire de *htyw* seul le complément de la préposition *r*. Ce mot est un pluriel lorsqu’il est employé comme terme géographique (cf. *htyw nw ntyw /nw* çš, *Wb.*, III, 349, 8–9); il faudrait donc *rn.šn*. En outre, pendant l’Ancien Empire, *mfkst* isolé⁵ ne s’emploie pas encore comme nom géographique;⁶ *htyw* et *mfkst* ne doivent donc pas être séparés ( détermine l’ensemble).

La solution du problème est fort simple. Il suffit d’examiner les fac-similés de Gardiner-Peet, *Sinâï*⁷ (voir figure ci-contre), pour constater qu’il y a  et non  après *htyw mfkst*.⁸ Le rond

¹ Or passively ‘like (a place) in front of whose fields one moves to and fro’. In any case, of the uncertainty that ensues when the boundaries of fields are not firmly fixed.

² Here I have myself been guilty of an undue literalism in rendering ‘free from stealing and carrying off’, which, moreover, gives a wrong idea of the origin.

³ Kees wrongly describes *tis* as a ‘pseudo-participle’. A participle is quite regular in such examples, and I do not think his view can be defended on the ground that the predicate *hurw* here is undefined in meaning. Gunn has rightly recognized *ts* (written *tis*; here and elsewhere, also *tis*, see *Wb.*, v, 243) as the original of Coptic τρωϥ, ‘become, be hard,’ which also (see Crum) has a transitive sense ‘fix’ and an intransitive ‘be fixed, implanted’.





⁴ Cf. Gunn, *Studies*, p. 40, n. 4; Gard., *Eg. Gr.*, § 197.



⁵ Cf. Gauthier, *Dict. géog.*, II, 162; III, 15, 34; *Wb.*, II, 57, 4. 5.

⁶ Cf. Weill, *Inscrip. du Sinâï*, 49, et *Sphinx* 8, 182.









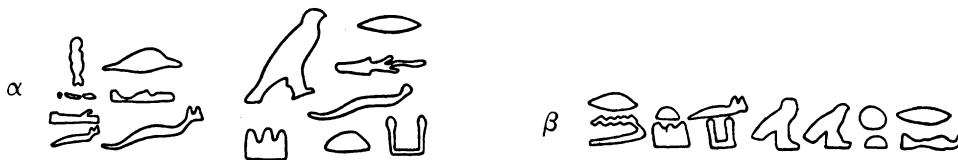





















⁷ α = n° 13; β = n° 17.

⁸ Seul Birch, *ZÄS* 7 (1869), 26, a lu  (en α).





















intérieur de  manque,¹ mais il en est de même dans  (une fois en α , partout en β); en α le contour est nettement celui de , et en β d'autres  sont faits exactement comme les .

En fait, le titre de l'inscription finit à *mfkst*, comme l'indique d'ailleurs, en α , la disposition même des signes,  étant nettement séparé de ce qui précède (cf. figure). Le groupe —qui, en α , est suivi de —doit certainement être rattaché à la liste de personnes qui lui fait suite,



son rôle étant semblable à celui qu'ont, dans d'autres inscriptions du même genre, les phrases:          A, B, C, \dots ,³ 'Liste de son personnel venu avec lui: A., B., C., . . .', var.        ⁴ et, sans *hn*^c,         ⁵ L'analyse de  reste toutefois difficile. On peut penser à: (a) un participe + datif: 'Ceux qui ont travaillé⁶ pour lui (α : pour lui avec lui): B., C., D., . . .', mais, bien que des formes sans terminaison soient attestées,⁷ on attendrait , d'autant plus que le participe serait employé sans antécédent; (b) un *sdm-f* + datif: 'Travaillent pour lui (α : pour lui avec lui): B., C., D., . . .',⁸ mais on attendrait 'Ont travaillé . . .' (*ir-n nf*); (c) un *sdm-nf*:⁹ 'Il a employé (α : Il a employé avec lui): B., C., D., . . .', mais il faudrait donner à  un sens spécial qui n'est pas attesté par ailleurs. En outre, pour le texte α , ces traductions ne sont guère satisfaisantes à cause du double suffixe: 'pour lui' semble superflu en (a) et (b), et en (c) c'est 'avec lui' qui paraît inutile. Le suffixe de  se rapporterait-il—*nf* étant un datif—au roi dont la titulature occupe le début de chaque inscription?

Quoi qu'il en soit, l'exactitude de la lecture  est assurée par les seules considérations paléographiques, et les textes doivent certainement être compris: 'Mission royale envoyée avec A. aux Terrasses de la Turquoise. Il a eu pour collaborateurs: B., C., D., etc. . .'

Le nom de la région du Wâdi Maghâra, dans ces inscriptions des Ve–VI^e dynasties, est donc simplement *htyw mfkst*, var. *htyw fkst*, 'Terrasses de la Turquoise', expression qui se retrouve telle quelle sur la Pierre de Palerme (      $Urk.$, I, 246—noter la place de ) et dans un texte du Moyen Empire (      JEA 4, 35 et Pl. 9), et qui est constituée comme l'expression bien connue        : 'Terrasses de la Myrrhe'.

J. J. CLÈRE.

The Medallion of Dahshūr

IN 1895 M. J. de Morgan discovered at Dahshūr among the jewellery of Princess Khnemet, a relative of Amenemhēt II, a small medallion with a design of a bull (or cow) couchant in white with black spots, on a background of greyish blue, surrounded by a border of rectangles coloured red, white, greenish yellow, and black. This design is covered with a thin circular piece of rock-

¹ Le fait est fréquent jusqu'à la XI^e dynastie.

² Omis par Sethe, *Urk.*, I, 56. Weill, *Inscrip. du Sinaï*, 115, y voit des signes d'un des noms de la liste ('Hamou . . . f').

³ Gardiner-Peet, *Sinaï*, n^o 92.

⁴ Couyat-Montet, *Hammâmât*, n^{os} 87; cf. aussi n^o 47.

⁵ Gardiner-Peet, *Sinaï*, n^o 106; cf. aussi n^{os} 115 et 117.

⁶ Pour  (sans objet) = 'travailler', cf. *Urk.*, I, 70, 8. 9.

⁷ Cf. Sethe, *Verbum*, II, §§ 844, 850; Gard., *Eg. Gr.*, § 359, *m. plur.*

⁸ En α le sujet multiple serait rejeté après *hn*^c (cf. Gard., *Eg. Gr.*, § 507, 2. 3; Couyat-Montet, *Hammâmât*, n^o 123, l. 3); il en serait de même de l'objet avec la traduction (c).

⁹ L'interprétation (c) m'est suggérée par B. Gunn qui m'écrit 'Have we perhaps *ir-nf* in *sdm-nf*, with  in a special meaning "ayant formé (l'équipe) . . ." or something of the sort?' et renvoie à *Wb.*, I, 109, 5.

crystal and is set in a gold frame. A poor photograph of it is published in J. de Morgan's *Fouilles à Dahchour en 1894-1895*, Pl. xii, 62, a slightly better one in Vernier, *Bijoux et Orfèvreries (CCG)*, III, Pl. lxxiii (52, 975). G. Legrain thus described it in de Morgan's volume, p. 67: 'Le monument le plus curieux de cette série est une pendeloque composée d'un médaillon de mosaïque ou plutôt de marqueterie, serti d'or granulé et couvert d'une mince <lame> de spath. Le sujet décoratif est composé d'un cercle multicolore de pierres vertes, blanches et rouges. Au centre se voit un bœuf (?) couché.' I remember discussing this little pendant with Legrain soon after it was discovered, and pointed out to him the improbability of its being of stone mosaic because the coloured rectangles in the border were irregular in size; I suggested that it might be of fused glass mosaic and Legrain was inclined to agree with me. In 1912 M. Maspero (*Art in Egypt, Ars Una* series, p. 120) described it as made of 'glass mosaic' and in the same year I commissioned Mr. Harold Jones to make a coloured drawing of it twice the size of the original which I published in this Journal, vol. 6 (1920), Pl. xvi, 1; at the same time I described the object (p. 159) as being of coloured glass mosaic. In 1934 Mr. H. C. Beck (*Ancient Egypt*, 1934, p. 16) republished Harold Jones's drawing of the pendant with the following comment: 'This specimen has caused more controversy than any other piece of reputed early glass. Dr. Lucas and Mr. Brunton are both convinced that it is not glass, but a stone mosaic. Professor Newberry, on the other hand, thinks that it is glass. He also considers that the question of its material cannot be finally settled until the piece of quartz which covers it is removed. The authorities, however, will not allow this to be done.' About the same year (1934) I was reading through Sir Arthur Evans's *Palace of Minos*, III (1930), and at once noticed the resemblance between the Dahshūr Medallion and the beautiful miniature bull-catching scene painted on the back of a crystal plaque which he had found at Knossos (*op. cit.*, Pl. xix, pp. 108-11). This year (1937) Mr. Brunton and Mr. Lucas (*Ann. Serv.* 36, 197-200) have re-examined the Dahshūr medallion with a 'Zeiss binocular, erecting, stereoscopic microscope' and have now definitely settled the question as to material; it is neither glass nor stone mosaic, but miniature-painting, though it is not stated whether it is painted on the underside of the rock-crystal, or whether the rock-crystal is merely a covering for a painting on another material.¹ This is the only point now to be settled regarding one of the most interesting pieces of ancient Egyptian jewellery that have as yet come to light.

PERCY E. NEWBERRY.

A Chinese Parallel to an Egyptian Idiom

THE interesting passage, *P. Chester Beatty I*, 3, 8 (ed. A. H. Gardiner 1931), in which the Master of the Universe angrily addresses Horus: 'Thou art feeble in thy limbs and this office is too great for thee, thou stripling, the taste of whose mouth is bad', is closely paralleled and elucidated by a Chinese text of the Han Dynasty. It is recorded in the official annals that when the founder of the Dynasty (at the end of the third century B.C.) heard of the appointment of a youthful general in an enemy's army, he said: 'His mouth still has the bad smell of milk; how shall he match with my general Han Sin [one of his veterans]?' The milk referred to is without any doubt human milk, since the Chinese have only recently taken to drinking cow's milk; and there is an expression commonly used in modern Chinese novels to describe a person too weak or too young for a heavy task: 'a youth upon whom the bad smell of milk has not dried'. From this Chinese parallel it seems likely that the somewhat obscure Egyptian phrase, 'the taste of whose mouth is bad', refers to the smell of his mother's milk and lays added stress on the youthfulness of Horus (*cf.* p. 16, n. 2 of Gardiner's edn.).











The determinative of 'youth' (Gard., *Eg. Gr.*, Sign-list, A 17) is clearly derived from the iconographic presentation of Isis suckling Horus, in many examples of which the child is shown with the first finger to the mouth. Standing figures of Harpocrates wearing the double crown display the same pose of the hand, which is quite distinct from the attitude of the seated man determining words for 'taste', 'speak', 'eat', &c. in which all four fingers are held out close together, though

¹ They also (p. 200) noticed independently the resemblance between the Dahshūr and the Knossos objects.

the back of the hand may be turned towards the owner's face or away from it. It would seem, therefore, that the single finger touching the lips has special reference to the relationship between the child and its mother, *i.e.* expresses the child's desire for milk. At the same time the confusion always present between taste and smell would be enhanced by the possibility of confusion between the two attitudes of the hand to the mouth in the hieroglyphic determinatives of 'youth' and 'taste' &c. respectively. The child pointing its finger to its mouth would in this connexion naturally suggest the sense of taste rather than the sense of smell.

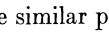
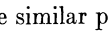

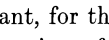
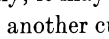



N. SHIAH.

The Writing of the Name *Hike'*.

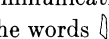
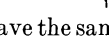









It is well known that in Ptolemaic and other late inscriptions the name of the god 'Magic',  is often written . This sign makes its appearance as early as Dyn. 21. In papyri and upon coffins of that period there is a scene in which Osiris sits upon a throne resting upon a double staircase, with a large snake before him whose body and tail cross the whole scene diagonally. Other divinities, which vary in their occurrence, appear before and behind Osiris. Those before are usually Horus and Thoth, those behind are Isis and Nephthys or Ma'et. The last figure behind Osiris, however, is invariable, and this is always *Hike'*, who holds two wavy serpents crossed in his arms. In these scenes the writing of the name and emblems of *Hike'* present some curious variations. In *P. Greenfield*, for instance, the legend above the figure of *Hike'* is (in a vertical column)  (*P. BM 10554*, ed. Budge, Pl. cviii). Here the , written beneath the standard, is probably influenced by the habitual writing of the name of Thoth (compare the late writing, under the same influence, of 'Min' as ) and may be ignored, the god's name being read and understood as . In the similar picture on the inner coffin of  (Cairo 61032; Daressy, *Cercueils des Cachettes royales (CCG)*, Pl. lvi), *Hike'* is called , and upon his head he wears the emblem . The coffin of Eshkons (Cairo 61030, Daressy, *op. cit.*, Pl. xlvi) presents another interesting variant, for the name of *Hike'* is sportively written above his head thus: . Here the word-sign consists of the hind-quarters of a lion *rampant*, instead of those of the usual lion *couchant*. Finally, it may be mentioned that upon the coffin of Pinūtem II (Cairo 61029; Daressy, *op. cit.*, Pl. xlv) another curious variation is to be found. Here *Hike'* is called  and upon his head he wears the emblem . This emblem is that of the female counterpart of the god,  'hmt of *Hike'*', concerning which see the interesting remarks by Dr. Gardiner, *PSBA* 37 (1915), 259.

WARREN R. DAWSON.

A Summary Writing of the Adverb *nii* in Old Egyptian?

THIS is the communication referred to in n. 2 on p. 6 of this volume in connexion with the translation of the words  in Nekhebu's Cairo inscription, l. 9. It should be noted that we have the same sentence, written  (the signs so disposed in the original), in *Urk.*, I, 256, 6; here it is possible to take the  as termination of both  and . One's first impulse is probably to read *šht nbt n-i* 'everything that is profitable to me'. But it also seems possible to take  either as prospective relative form or as imperfective passive participle, and  as a summary writing of the adverb  pointed out by Gardiner in *PSBA* 40, 5 ff., and to translate 'everything because of which I may become-(or, one becomes-)a-spirit'.¹ To decide between these two possibilities it would be necessary to have evidence of a definite rule as to the relative positions of *nb* and *n*+suffix when they are used together. But such examples of this collocation as I can adduce, after considerable search, in which friends have aided, is strangely scanty and conflicting. For the order *n*+suffix, *nb* I can give only *rdit-nf n-i nbt* 'everything that he has given to me', *Kah. Pap.*, 12, 9, pointed out to me by Dr. Gardiner, and *dd(w) [n]f sw nb* 'every one

¹ This translation of the verb *šh* is of course merely conventional.



to whom it is given', *Urk.*, iv, 1114, 9. For the other order I have *irrt nbt n:f* 'everything that is done for him', *Bk. Dead*, Nu, Sp. 144, rubric, end, and *šrw nb n:f sw* 'every one to whom it is assigned', *Urk.*, iv, 1116, 7. Thus in the same inscription and in exactly the same construction we have both orders (*Urk.*, iv, 1114, 9; 1116, 7). Taking, as subsidiary evidence, the possible position of *nb* with regard to the word it qualifies, that it may on occasion be widely separated from the latter is shown by *w^c im:tn nb* 'every one of you', Gard., *Eg. Gr.*, p. 76, n. 3; *šdd r pn nb hr:f* 'every one over whom this spell is read', *Urk.*, v, 97, 1 (P. Ani!), shown me by Mr. Dakin; and *šh m r:f nb* 'every one who is "spiritual" through his utterance(?)', *Pyr.*, 930c etc. Yet, against the order *im nb* in the common *w^c im nb* 'every one of them' we have *nb im* four times in ll. 6, 7 of the Cairo inscription of Nekhebu itself. The evidence thus goes to show that there was no strict rule as to the position of *nb*. A point, however, in favour of taking  as a writing of *nii* in the Nekhebu inscription and *Urk.*, i, 256, 6, is the use of *nii* in the closely similar sentence *iw-i rh-kwi ht nb(t) šht šh nii* 'I know everything because of which the spirit becomes-a-spirit' quoted by Gardiner, *PSBA* 40, 5; see now also *Urk.*, i, 173, 18 (note that *nii* here does not, like *n*+suffix, precede a nominal subject); and for *šh n* 'to become-a-spirit because of' something cf. 'I know   every magic because of which I may become-(or, one becomes-)a-spirit in the Necropolis', *Urk.*, i, 263, 14. If we admit that  is a possible writing of  in Old Egyptian (compare the remarks in *Sup. Gard. Eg. Gr.*, 15, on  as a *Middle-Egyptian* writing of the adverb *ny* or *nii*), we may perhaps see it also in the sentence immediately following this,     and translate 'I have done everything because of which I may become-(or, one becomes-)a-spirit'.

I should be grateful for communication of further examples of the use of *nb* and *n*+suffix together.

BATTISCOMBE GUNN.

The 'Golden Horus' Title

MAY I, with all diffidence, submit a suggestion concerning , the portion of the Pharaoh's titulary which is translated by some authorities as 'The Golden Horus' (*Hr nbw*) and by others, following a possible indication of the Greek *ἀντιπάλων ὑπέρετρος* of the Rosetta Stone, as 'Horus conqueror of the Ombite (Seth)'. Is it not possible that it denoted 'Horus and the Ombite (Seth)', that is, 'the Two Powers' (*šhmwy*), the usual designation of the pair in combined sovereignty? (I would refer to the position of Seth as explained by H. Kees in his *Horus und Seth als Götterpaar*.) It would thus denote the incorporation in the reigning Pharaoh of the active virtues of the two chief powers which in olden times had divided the lordship of the land; the Falcon, having subjugated the Ombite, would be set above him, but the virtue of the latter with respect to his original share of the land would not wholly lapse.

This is surely a happier presentment than one which would only perpetuate the memory of bitter wars of old. The fusion of the pair is of course indicated in the formal epithet of the queen of the Pharaoh as , 'she who sees Horus-and-Seth'. True, a common writing for the pair of gods is a group of two falcons, as well as , both reading *nbwy*; but perhaps we may surmise an earlier one giving a clear indication of Seth's ancient position of power and surviving into the classical age: some confusion of thought in later times may have suggested the connexion with 'gold' (Gard. *Eg. Gr.*, p. 73).

The interpretation here suggested would account for the Greek rendering as 'victorious over enemies', for the idea of 'power' can obviously have a close connexion with that of 'victory'; moreover *ἀντιπάλων* being in the plural may well mean enemies in general and not specifically Seth.

G. D. HORNBLOWER.

NOTES AND NEWS

Mr. H. W. Fairman, our Acting Field Director in Nubia last season, writes:

'The Nubian Expedition commenced its excavations on December 20, 1937. The main objective of the expedition was the completion of the excavation of Sesebi, and this task was completed by February 13, 1938. The work involved the clearing of the whole of the south-eastern section of the town,—a very badly damaged area,—some work in the centre of the town, which revealed a block of offices and administrative buildings and interesting remains of a drainage system, the completion of the excavation of the western section of the town, and the excavation and study of the great brick-lined trench found last season. The most interesting portion of the work was a large mound in the extreme south-eastern corner of the town. Under two medieval tombs lay a large, well-built house which had been built after the reign of Sethōs I, below this lay another house, presumably of the early Nineteenth Dynasty, and under all lay an enormous, brick-lined, well-like construction which may have been a prison or series of storage chambers. Intact foundation-deposits were found at the south-eastern corner of the town wall, and in the centre of the town in connexion with the temple; they prove that the foundation of both town and temple was the work of Amenophis IV. The other finds include several small stelae, a number of scarabs and fragments of relief, and many other small objects.

'On the completion of the work at Sesebi the men and work were removed to the Society's new concession at 'Amārah, and twelve days were spent in examining the ancient site of 'Amārah West. This proves to be a large town mound which has been buried deep in sand. Apparently the town has suffered very little from modern robbing, and the houses appear to be very well preserved. The Temple presents unusual features in plan and orientation, and is inscribed both inside and outside. Since the walls are preserved to a height of at least six or seven feet a very considerable proportion of the temple reliefs and inscriptions remain, and many of them retain their original colours. Historical inscriptions of Ramesses II, Merneptah, Ramesses VI, and Ramesses IX were discovered, including two large stelae of Ramesses II, one of which, though incomplete, contains 32 lines and makes some reference to the marriage of Ramesses II and the daughter of the King of Khatti. The extent of the temenos area and its various gateways, one of which may yet prove to retain its roofing blocks in their original position, was defined and planned and the approximate extent of the town was traced, and the extensive cemeteries to the north and east of the town, which do not appear to be completely plundered, were located. The expedition found evidence of an occupation of the town before the reign of Ramesses II, an occupation which is apparently not later than the late Eighteenth Dynasty. It is clear that the site is a well-preserved one that will produce interesting results, including much inscriptional material, and there is every hope of finding objects, including, very probably, statuary, in a good state of preservation. Thus the site should well repay excavation.'

Mr. Oliver H. Myers sends us the following notes on the work of the Sir Robert Mond Expedition last season:

In view of the Saharan Congress to be held in Paris this year the expedition has devoted the entire 1937-8 season to further study of the Saharan remains at Armant.

Previously many problems had been raised but none solved. We had found only surface sites, on which associations were doubtful, and dating was therefore guesswork. Moreover we did not know how far the intrusion extended, nor from which direction it came.

The first half of the season was spent at Armant, the second half in the Western Desert in search of the routes by which the Saharan peoples reached the Nile.

Having decided to treat the sites as purely surface ones, we needed a new technique. We adopted

the statistical method in two ways: first, in searching for the maximum number of sites and seeing if the same associations were present in all, and second, by 'squaring' each site occupied by more than two cultures, in order to trace graphically the relative distribution of the latter. These methods proved eminently successful: with the first, over thirty sites made it clear that the Saharan sherds were associated with pottery of the Old Kingdom; by the second we were able to prove that the flints found were associated with the Saharan culture, and not with a separate neolithic one. Thus we had not only the date of this curious intrusion but also the first dating-point for the Saharan cultures, previously undated.

To find the route by which these people came, two small expeditions were sent out, one northward as far as Abu Shūshah, and one southward to Edfu. The northern expedition found the last Saharan sherds on the north of the concession; the southern one found them all the way. From our results it seemed probable that the people did not traverse the great dry desert around Khargah and Dakhlah oases but came by a southern route and down the Nile. This was confirmed by the second part of the season's work, an expedition to the Gilf Kebīr and 'Uwēnāt. During the first month we explored an area in the centre of the east side of the Gilf Kebīr. Here we found an amazing Chellean and Acheulean site with implements *in situ* beside an ancient lake. By marking the bearing of each 'flint' we found that the wind had remained within a degree or two of north since the occupation of the site. All the implements were made from flakes of quartzite or silified sandstone. In the centre of the lake, belonging to a much later and briefer wet period, we found remains of a neolithic occupation. Digging into the lake we found alternate layers of mud and sand, showing that, whereas it has generally been supposed that all mud pans in the Sahara have long been eroded away, this site has been building up. The two most important neolithic sites were found near the heads of *wadis* which had been closed by sand-dunes and had formed lakes. In these was found pottery similar to that from Armant, ostrich-shell beads, decorated ostrich-shells, polished stone adzes, two crude stone carvings, microlithic chalcedony cores, and stone implements of various kinds in superabundance. In another lake-site definite stratification was found.

The second month we devoted to 'Uwēnāt, trying to find out whether the rock drawings and paintings were related to any of the Saharan cultures, especially the Armant Saharan. Ill health overtook us here, but despite difficulties our results were most satisfactory. We found material identical with the Armant Saharan, possibly to be associated with the last phase of the paintings, the representation of oxen in white. We found a pot with holes for suspension, and the remains of poles from which pots were suspended, as shown in the paintings. The Gurān who were inhabiting 'Uwēnāt in 1927, and whose caves and house we examined, used the same methods of suspension, and their pottery bore clear affinities to the Saharan. Of the paintings the great majority are of cattle, but the most interesting show the daily life of the people. It is impossible to leave the subject of these painted caves without commenting on the shortsighted policy which allows copying expeditions to work their will on them with complete disregard of scientific method.

Saharan sherds in considerable quantity are also reported from Khargah. These are almost certainly of much later date, and suggest that until the Persian Conquest the oasis belonged culturally to the Saharan civilization rather than to the Egyptian.

An Exhibition of the results of the Society's work in Egypt and the Sudan is being held at the Palestine Exploration Fund, 2 Hinde Street, London, W. 1, from June 23 to July 14.

On March 9 Dr. Alexander Scharff, Professor of Egyptology at Munich, gave a lecture under our Society's auspices on 'Egyptian Sculpture of the Pyramid Age' at the Royal Society's rooms at Burlington House. The lecture, at which Dr. Gardiner took the Chair, was warmly appreciated. Prof. Scharff is kindly letting us have the manuscript for publication in the *Journal* later.

A lecture illustrated by lantern slides on 'Excavations at Sesebi and 'Amārah West, Sudan, was given by Mr. H. W. Fairman at the Royal Society's rooms, Burlington House, on June 30.

We have decided to print the annual 'List of Abbreviations used in References to Periodicals, etc.' at the end of each volume rather than (as stated on p. 119 of vol. 23) in the middle.

The latest publication of our Society is *Cemeteries of Armant, I*, which appeared a few weeks ago. This work is by Sir Robert Mond, our Chairman, and Mr. Oliver H. Myers, the Field Director at Armant, and also has chapters by Mr. T. J. C. Baly, Prof. J. Cameron, Prof. A. J. E. Cave, Suliman Effendi Huzayyin, Dr. J. W. Jackson, and the Rev. De Lacy O'Leary, and contains a full account of everything found and purchased by the Robert Mond Expedition down to 1935, apart from what was published in *The Bucheum*. Actually more than fifty experts have contributed to this extraordinarily full report of an excavation. The work, which is in two volumes containing 300 pages of text and 75 plates respectively, is being sold at the very low prices of twenty-five shillings to the public, one guinea to Members and Associate Members.

The Twentieth International Congress of Orientalists will be held at Brussels on September 5 to 10 next, under the patronage of H.M. The King of the Belgians. The President is Prof. J. Capart, who is also President of the Section of Egyptology and African Studies; the Secretary-General is Prof. G. Ryckmans, of the University of Louvain.

The greatest concern has been caused by the dispatch which appeared in *The Times* of April 5, from that Journal's Cairo correspondent, headed 'Vandalism at Thebes', and detailing a number of grievous mutilations of the Private Tombs perpetrated last summer. The following are the facts as given by *The Times*:

At Tomb 217 (of the sculptor Ipy), a piece has been cut out in a locked tomb, presumably, therefore, with the connivance of the guards.

At Tomb 75 (of the second Prophet of Amūn, Amenhotpe-sise), all the faces, which were perfect, have been cut out. The tomb was entered through a breach, and a good deal of excavating had to be done, obviously quite openly and by daylight.

In Tomb 61 (of the Vizier User) the few faces which were perfect have been cut out. The tomb was entered from behind after much cutting.

In Tomb 226, the only painting was protected by an iron grating. The miscreants thrust their hands through this and defaced the figures. As nothing could be taken away this damage must have been done in wanton mischief.

Tomb 119 lies open; the scene of the Syrians was partly cut away.

In Tomb 227 one or two figures have been cut out.

A heavy responsibility rests upon the Antiquities Department of the Egyptian Government to protect by every means in its power the treasures of ancient art of which it is the custodian; and not Egyptologists alone but the whole world of archaeologists and of art-lovers will earnestly hope that that Department will take such steps as may be necessary to prevent any repetition of the irreparable damage that has occurred. The ancient tomb-robbers, while rifling the tombs of their contents during periods of governmental laxity, did at least leave us the decorated walls; but with the increasing commercial value of Egyptian antiquities, and perhaps the existence of feuds among the local guardians, the paintings also are doomed unless strict surveillance and discipline be exercised.

Prof. Hermann Ranke, whose withdrawal from his Chair at Heidelberg we mentioned in the preceding volume, has been appointed visiting Professor of Egyptology at the University of Pennsylvania, Philadelphia, and Curator of the Egyptian Section of the Pennsylvania University Museum. Some time ago Dr. C. E. Sander-Hansen succeeded Dr. H. O. Lange as Lecturer in Egyptology in the University of Copenhagen.

The statement, on p. 264 of the preceding volume, that Dr. Siegfried Schott has succeeded Prof. Ranke in the Chair of Egyptology at Heidelberg, was an error which we regret.

We have pleasure in recording that the prize offered for an essay on a subject connected with prehistoric or Pharaonic Egypt (see *JEA* 22, 214) has been unanimously awarded by the judges to Mr. Theodore Burton Brown for his paper on 'The "First Intermediate Period" of Egyptian History'. Ten essays were sent in, from England, America, France, Egypt, and the Sudan. The judges state that 'the standard was high, and more than one essay was of outstanding merit', and that the prize paper is 'clearly a valuable contribution to our knowledge of early movements in the near East'.

Dr. Bell writes:

'A joint expedition of the Institut français d'archéologie orientale at Cairo and the University of Warsaw, under the direction of M. Bruyère began, on the 3rd January 1937, an excavation at Tell Edfū. The first season lasted till the 26th February, and its results are described in a volume *Tell Edfou 1937* recently issued from the press of the Institut français. They appear to be of some importance, and among the finds are a considerable number of Greek ostraca from the Jewish quarter, a few Latin ostraca, and some Byzantine papyri, all of which are edited in the volume referred to above by Prof. J. Manteuffel.

'The excavation was continued in the season just past. Prof. Manteuffel tells me in a private letter that some more Greek texts were discovered. The further progress of the work will be followed with interest, and papyrologists will hope that our stock of papyri from the site may be yet further increased.'

British papyrology has suffered a heavy loss by the sudden death, on May 10th, of Mr. Campbell Cowan Edgar. We are indebted to Dr. Bell for the following lines on Edgar as a papyrologist and man:

'His earlier work was done in the sphere of archaeology, not papyrology. In a series of volumes contributed to the *Catalogue Général* of the Cairo Museum from 1903 onwards he dealt with a wide range of antiquities from Graeco-Roman Egypt, sculpture, bronzes, glass, vases, coffins, etc. It was other scholars, Grenfell and Hunt, Preisigke, Jean Maspero, who catalogued or edited the earlier acquisitions of papyri. When, however, the Museum came into possession of a large portion of the famous Zenon archive, Edgar undertook the task of editing these documents. His previous work had given him a good knowledge of the Graeco-Egyptian background; but to take up in middle age the decipherment of papyri offering, as many of these did, considerable difficulties, was no small task. A considerable selection from the archive was issued in successive numbers of the *Annales du Service*; and the admirable editing which these received showed already the master hand. These papyri were widely quoted and incorporated in the *Sammelbuch* as 'P. Zenon'. Subsequently the whole collection, including those which had already appeared in the *Annales*, was published, with the exception of mere scraps, in four large volumes of the *Catalogue Général*. At the time of his death Edgar was engaged in preparing for publication a further instalment of Zenon papyri recently acquired by the Cairo Museum.

'Edgar's work on these Cairo papyri established his reputation as the foremost authority on the career of Zenon and his environment. He reveals throughout a wide knowledge of the period, admirable skill as a decipherer, and a judgement as acute as it was cautious and critical. It was natural and proper, therefore, that the University of Michigan should commission him to edit its considerable collection of Zenon papyri (*Zenon Papyri in the University of Michigan Collection*, Ann Arbor, 1931). He also edited the Zenon papyri in the John Rylands Library, Manchester, which he published in the *Bulletin* of that institution.

'His work in papyrology was by no means confined to the Zenon archive. He collaborated with Prof. Hunt in the two volumes of *Select Papyri* included in the Loeb Series; he republished several of the Petrie Papyri and edited other miscellaneous texts; and on Hunt's death he undertook the very laborious task of completing the work on Part II of Vol. III of the *Tebtunis Papyri*. This volume is very nearly finished and may be expected before long, though its appearance will be somewhat delayed by Edgar's death.

‘Naturally modest and retiring, Edgar had received, apart from an honorary Lit.D. of Dublin, far less recognition than he deserved. Probably he would not have had it otherwise; for he thought always of the work rather than the reward and was more concerned to attain his own high standard than to win the praise of men. He will be remembered by his friends as a man of great kindness of heart and of a personality which, when understood, could not fail to be appreciated.’

Born at Tongland Manse in 1870, Edgar was educated at Ayr Academy and Oriel College, Oxford. In 1895 he was elected to a Craven Fellowship, and spent a year in Munich studying under Furtwängler; he then joined the British School at Athens where he remained four years, working in the museums of Greece and Italy, and taking part in excavations. In 1900 he went to Cairo, where he joined the Catalogue Commission of the Antiquities Department. In 1905 he became Inspector-in-Chief of Antiquities in the Delta, a post which he held until 1919, when he entered the Egyptian Museum, Cairo, as Assistant Keeper. Later he became Head Keeper, and in 1925 Secretary-General of the Department. In 1927 he retired from the service of the Egyptian Government, and left Egypt to settle with his family in Berkhamsted. Since his retirement he had been a member of the Committee of our Society, and recently he had given much-valued help to the Editor of this *Journal* in matters connected with the Graeco-Roman Period.

The deaths of archaeologists are very seldom violent, but a tragic fate befell Mr. J. L. Starkey, Director of the Wellcome-Marston Expedition at Tell ed-Duwēr (Lachish), who was shot dead in his car by Arabs on January 10th near Bēt Jibrīn while on his way to the opening of the new Archaeological Museum in Jerusalem. For a number of years Mr. Starkey was associated with Sir Flinders Petrie, whose excavations at Qāw and Badāri he joined in 1922 on his first visit to Egypt, afterwards following Sir Flinders to Palestine, and digging at Tell Gemmeḥ, Tell Fara, and Tell el-‘Ajjūl. About six years ago he began to excavate Tell ed-Duwēr, in southern Palestine, with the support of Sir Henry Wellcome, Sir Charles Marston, Sir Robert Mond, Mr. H. Dunscombe Colt, and latterly of the Trustees of the Wellcome Foundation. His work on this important site, on which he was still engaged at the time of his death at the age of 45, brought to light, among many other objects, a bowl giving valuable evidence of the use of the ‘Sinai Script’ in Palestine, and later the very remarkable group of Hebrew ostraca on sherds, of about 600 B.C., which have been so widely discussed and of which a full publication by Prof. H. Torczyner has lately appeared. He was buried at the Protestant Cemetery on Mount Zion on January 11th, and a week later a memorial service, attended by a large number of archaeologists and others, was held at St. Margaret’s, Westminster.

With much regret we record the deaths of two eminent French Egyptologists: Prof. Alexandre Moret, on February 2nd, and M. Georges Daressy, on February 28th. M. Moret, born in 1868 at Aix-les-Bains, was Maître des conférences in the Faculty of Letters at Lyon from 1897 to 1899; moving then to Paris, he became Directeur d’études at the École pratique des Hautes Études from 1899 until his death, and Professor at the Collège de France from 1923 onwards. For some twenty years he was Keeper of the Musée Guimet; in 1927 he was elected a member of the Académie des Inscriptions et Belles-Lettres. In his publications Moret specialized in Egyptian religion, history, and sociology; more than any other professional Egyptologist he was influenced by the theories associated with Frazer’s *Golden Bough*. In addition to his more serious work he found time to publish several popular books which have done much to maintain interest in ancient Egypt among the French public; of two of them English translations (*In the Time of the Pharaohs; Kings and Gods of Egypt*) by Mme Moret have appeared.

M. Daressy was born at Sourdon (Somme) in 1864, and became Assistant Keeper of the Būlāk Museum in 1887. Among other valuable services to Egyptology he continued the clearing of the Luxor Temple, begun by Maspero in 1885, took part in the discovery of the mummies of the Priests of Amūn of the Twenty-first Dynasty in 1891, completed the clearing of the Temple of Medīnat Habu, and arranged the collections of the Egyptian Museum when it was transferred first to Gīzah in 1891 and again to Qasr en-Nīl in 1902. In addition to writing several volumes of the *Catalogue*

Général, he contributed an immense number of articles, on antiquities in the Egyptian Museum and other subjects, to the *Recueil de Travaux . . .*, the *Annales du Service*, the *Bulletin de l'Institut français*, the *Bulletin de l'Institut égyptien*, &c. In 1914 he was appointed Secretary General of the Antiquities Department, of which he was Acting Director General during the War. He retired in 1923. As a contributor to periodicals he was probably the most prolific of all Egyptologists. For some years before his death, however, he had ceased to write.

Dr. W. E. Crum kindly sends the following lines:

‘With the death, in his 70th year, of Professor Carl Schmidt, which befell in Cairo on Easter Day, the editor of the most important Coptic texts and the discoverer of not a few of the most important Coptic manuscripts in our day has gone from us. Schmidt was a Mecklenburger and became a pupil at Berlin of Erman and Steindorff, besides attaining distinction as a classical scholar. But his bent was always towards historical theology and from 1899 onwards he taught in the theological faculty, where and at the Academy he was for many years closely associated with Harnack. His principal publications were critical editions of the Bruce gnostic papyrus in the Bodleian, of the Acts of Paul in a then unknown Coptic dialect, of the Epistle of Clement in Achmimic, and of the Dialogues of Jesus and His disciples (*Gespräche Jesu*) likewise in that dialect. Some of his most valuable work was done upon the *Pistis Sophia*, which he edited and translated afresh. All his publications are characterized by the minutest accuracy and the abundant—perhaps overabundant—commentaries by great learning. The remains of the gnostic heresies and of extra-canonical literature continued throughout to be his chief interest; his last years were absorbed by the newly discovered Manichaean papyri, whereof he had been the first to recognize the character and in the editing of which he took an active share. At the end of his life he had thought it his duty to write in defence of the authenticity of the early Christian documents, which was being attacked, with more zeal than knowledge, by the partisans of General Ludendorff’s anti-Christian movement (see *Die junge Kirche*, 1937).’

With the deepest regret we learn, while going to press, of the death from pneumonia, on May 31, of Mr. Alan Wynn Shorter, Assistant Keeper in the Department of Egyptian and Assyrian Antiquities of the British Museum. A notice of Mr. Shorter by Professor Blackman will appear in our next part.

CORRESPONDENCE

To the Editor,

Journal of Egyptian Archaeology.

Sir,

May I ask for the help of readers of the *Journal* in tracing the subsequent history of statues and inscribed blocks which have been removed from their original positions in Egypt?

While preparing material for the *Topographical Bibliography*, I have been trying to do this, and find that while most of them are now in museums, I sometimes reach a dead-end when the particular object has disappeared into private possession where it remains hidden, awaiting a second excavation. The larger and better-known private collections present little difficulty, as most of them have been catalogued and some have already passed through the sale-room to a final resting-place in a museum. But it frequently happened in the nineteenth century, when antiquities could be bought cheaply everywhere in Egypt, with no restriction on their export, that travellers brought home a few 'souvenirs' of this nature, sometimes with records of when and how they were discovered. These original owners are almost all dead, and it often happens that their collections, being white elephants to their heirs, disappear into attics or else find their way to local dealers or museums, generally with no record of the transaction, so that any indication of the provenance is completely lost. For instance, can any one tell me what has happened to the Meux Collection, published by Budge in 1896, which does not seem to have gone to Lady Meux's heirs, or to have been disposed of at any important auction-sale? And what has become of the statue from the tomb of Hekail in Aswān, brought home by Sir Edward Malet in the eighties?

In these days of flats and the breaking-up of big estates, the dismantling of larger houses proceeds apace. Would it not be possible, before it is too late, to make a census of Egyptian antiquities still in private possession or local collections, and at the same time to rescue any records concerning them in the shape of old diaries, labels, and so forth, before they are consigned to the dustbin as of no literary or pecuniary value? If any readers of the *Journal* know of the existence of such objects (especially statues or stelae) in private houses, or of old diaries and drawings made by early travellers in Egypt, I should be very glad to hear from them.

The Griffith Library,
Sandridge,
Boars Hill, Oxford.

Yours faithfully,
ROSALIND MOSS.

REVIEWS AND NOTICES OF RECENT PUBLICATIONS

Greek Ostraca in the University of Michigan Collection. By LEIV AMUNDSEN. Part I: Texts. (University of Michigan Studies, Humanistic Series, vol. xxxiv.) Ann Arbor, University of Michigan Press, 1935. xx+232 pp., 8 pls. \$3.50.

Apart from the critical notes and a few suggestions for the interpretation of single words, this volume contains the texts only of the ostraca published, the commentary being reserved for Part II, which has not yet appeared. This fact makes the book a little difficult to review, and I must content myself in the main with a description of the contents.

The ostraca here published fall into two categories. The second and largest consists of those found in the University of Michigan's excavations at Karanis in the years 1924-9, and they date mostly from the latter part of the third and the earlier part of the fourth centuries. This limitation of date does not appear to be accidental; as the editor points out in his preface, the finds suggest that the use at Karanis of potsherds as a writing material was infrequent in the earlier and more prosperous period of Roman rule but became increasingly common later on, as prosperity declined. The other section of the volume contains a more miscellaneous collection of ostraca, those bought at various times from or through Dr. Askren.

With very few exceptions the ostraca of both classes are of the Roman period, and all are certainly or presumably from the Fayyūm. The earliest is No. 1, which the editor dates as 'probably Sept. 6, 235 B.C.-Oct./Nov. 234 B.C.' This dating must, however, be questioned. The symbol in l. 4 which Dr. Amundsen reads χ', explaining doubtfully as χ(αλοῦ), is certainly the talent sign; the extension is (τάλαντα) γ (δραχμαὶ) ἄνω. So large a sum must be in the copper currency, and the date can therefore not be as early as the 12th year of Euergetes I (see Fr. Heichelheim, *Wirtschaftl. Schwankungen*, p. 18). The hand precludes a date in the second century; hence we may take the 12th year mentioned as that of Philopator (211-210 B.C.). The possibility therefore suggests itself that this ostrakon may belong to the collection found at Philadelphia and published in BGU VII. Mr. Skeat observes that the symbol at the beginning which Amundsen takes as (λόγος) or π(ερί) is probably νπ for ὑπ(όμνημα).

No. 2, which mentions Ζήνωνος, recalls the Zenon archive, especially as the other two names mentioned are known there; but the editor dates it second or first century B.C., and since he must have thought of the possible connexion with the third-century Zenon, his dating is no doubt to be accepted.

In reading through the volume one notices at once a difference from the older collections of ostraca. In the latter the Theban district or Coptos or Elephantine is the provenance of the great majority; the ostraca in Amundsen's volume come from the Fayyūm, and this difference in origin corresponds to a difference in the character of the texts. The tax-receipts, which bulk so largely elsewhere, are proportionately less numerous here; and even where we find such receipts they relate to taxes different from those found in the majority of the ostraca previously known. For the present collection dates, in large part, from a period when the tax system was being simplified; when in place of the many imposts seen in the first, second, and early third centuries we meet with but two or three main classes. Thus in Nos. 177-233 we find a long and interesting series of receipts for chaff. The chaff was intended usually, if not invariably, for fuel, and in many receipts it is indeed called ἀχύρου καυσίμου. Sometimes it is destined for Babylon (e.g. 189, 196), in one (219) εἰς ὑπόκασαν γυμνασίου Ἀλεξανδρείας.

Another series (266 ff.) relates to work on the embankments, consisting partly of lists of workers with their quotas, partly of certificates of work performed for the *corvée*. Others refer to transport. Several of these contain the heading πολ(ιτῶν) δημόσιος, which is rather puzzling in the absence of a commentary. Does it refer to donkeys supplied by metropolitans for the δρόμος δημόσιος? Doubtless Dr. Amundsen will deal with this question in the commentary volume.

There are, indeed, many small points which are of interest, and the commentary, more necessary even than with longer texts if the ostraca here published are to find their full utility, will be eagerly expected. Meanwhile Dr. Amundsen is to be congratulated on his admirable performance of a difficult task.

H. I. BELL.

Histoire économique et sociale de l'ancienne Égypte. Von G. DYKMANS. Bd. I: Des origines aux Thinites; Bd. II: La vie économique sous l'ancien Empire; Bd. III: L'organisation sociale sous l'ancien Empire. (Bibliothèque de l'école supérieure de sciences commerciales et économiques de l'Université de Liège, Bde. 13, 15, 17.) Paris, Auguste Picard, 1936–7. 8vo. 305, 301, 281 Seiten. Gesamtpreis 150 fr. Fr.

Das hier vorliegende dreibändige Werk des belgischen Wirtschaftsgeschichtlers und Soziologen kann als eine der anregendsten Neuerscheinungen bezeichnet werden, die der Ägyptologie von nichtägyptologischer Seite in den letzten Jahren zuteil wurden. Im Vorwort betont Verf. ausdrücklich 'cette étude que nous livrons aux spécialistes, n'est pas une œuvre définitive. Nous aimerions qu'elle fût considérée comme une synthèse critique de nos connaissances actuelles, capable de guider nos continuateurs dans une voie moins hasardeuse' (S. 11). Daher soll eine Besprechung dieser Selbstbeschränkung gerecht werden und keinen kleinteiligen Maßstab anlegen.

Der erste Band, der vielleicht als der wertvollste angesehen werden kann, behandelt die Wirtschafts- und Sozialgeschichte der Vorzeit. Nach einem einleitenden Kapitel über den Schauplatz der Ereignisse, das sehr aufschlussreiche Angaben über die durchaus nicht mit Recht berühmte ägyptische Fruchtbarkeit enthält (S. 21 ff.), gibt Verf. einen ausführlichen Überblick über das vorgeschichtliche Material von der Altsteinzeit bis zum Ende der zweiten Negadekultur. Um zu einer Ausdeutung der rein archäologischen Tatsachen zu gelangen, macht Verf. den Leser zunächst mit den wirtschaftlichen und sozialen Ursprüngen und den darüber herrschenden Meinungen vertraut. Dabei empfindet man die Ablehnung der ausgesprochen entwicklungstheoretischen Anschauungen Karl Büchers, Levy-Brühls und ihrer Anhänger, die abwägende Stellungnahme zu anderen Autoren (Dürkheim, Frazer) und die vorsichtige Darlegung einer eigenen Auffassung als wohlthuend und, wie seine Ausführungen an Hand der ägyptischen Vorgeschichte zeigen, gerechtfertigt. In einem weiteren Kapitel werden die beiden Negadekulturen besprochen. Nachdem die ersten Bewohner des Niltals von der östlichen und westlichen Hochfläche herabgestiegen und sesshaft geworden waren, ergab sich die Möglichkeit für eine neue wirtschaftliche Ordnung und soziale Gruppierung. Die anthropologischen und archäologischen Gegebenheiten finden eine eingehende Würdigung; desgleichen werden die Beziehungen aufgezeigt, die zwischen dem ursprünglich als soziologische Erscheinung zu wertenden Totemismus und der sich jetzt ausbildenden Religion bestehen. In einem ausführlichen Abschnitt finden die religiösen Grundlagen der Vorgeschichte eine Erörterung, die sich im wesentlichen an Sethes *Urgeschichte und älteste Religion der Ägypter* anschliesst. Dabei kommt Verf. auf den zweifelsohne vorhandenen Wesensunterschied zwischen Ober- und Unterägypten zu sprechen. Für Oberägypten nimmt er eine Feudalordnung an, deren Entstehung er auf ein allmähliches Anwachsen des Familiengrundbesitzes zurückführt (S. 193); während Verf. meint, dass im Delta eine durch Seefahrt und Handel zum Wohlstand gelangte Bourgeoisie sass, die in ihren grossen Städten nach den Regeln einer demokratischen Verfassung lebte. Diese von Pirenne (*Histoire des institutions et du droit privé de l'ancienne Égypte*, I, S. 51 ff.) übernommene Theorie ist historisch gesehen keinesfalls haltbar, da einerseits die beiden angenommenen politischen Formen im Kulturablauf eines Volkes zeitlich nacheinander anzusetzen sind (für Ägypten die I. Zwischenzeit und das Mittlere Reich) und andererseits für eine so frühe Zeit unmöglich mit derartigen Lebensformen zu rechnen ist. Diese Fragen sind letztlich Sache eines historischen Gefühls und nicht mit Tatsachen zu widerlegen (aber auch nicht zu beweisen!); wer wollte jedoch die Bewohner der Handelsplätze der Hallstadt- und Latènezeit im Abendland als satte Bourgeoisie ansprechen? — Ein besonderes Kapitel ist dem Aufkommen des Kupfers und den Anfängen der Metallurgie gewidmet. — Zum Schluss behandelt Verf. die Beziehungen Ägyptens zu seinen Nachbarländern eingehend. Hierzu sei erwähnt, dass die *nḥšj* hamitische Nubier und nicht Neger sind, diese treten erst in der 18. Dynastie direkt mit den Ägyptern in Berührung, wie Junker in seinem Aufsatz *The first Appearance of the Negroes in History* im 7. Band dieser Zeitschrift gezeigt hat. Das Verhältnis Ägyptens zu Palästina, Syrien und Mesopotamien zeichnet Verf. mit der ihm eigenen Vorsicht und Zurückhaltung, ohne dabei eine wesentliche, früher geäußerte Meinung unberücksichtigt zu lassen. Morgans 'asiatischer Einfluss' und Petries 'dynastisches Volk' werden selbstverständlich abgelehnt. Die fast satirische Zurückweisung der zahlreichen Kulturwanderungstheorien (Elliot Smith) und der phantastischen Spekulationen (Waddell) ist erfrischend zu lesen. (Es wird vielleicht manchem noch nicht bekannt sein, dass nach den Ansichten von Waddell Menes ein Sohn Sargons des Grossen war und im Jahre 2641 an den Ufern Irlands verschied!) — Eine nützliche Zusammenfassung des vorgetragenen Stoffes beschliesst diesen Band.

Der zweite Band, dem ein Vorwort von Pirenne vorangeht, untersucht die Wirtschaft des Alten Reiches. Nach einer kurzen Darlegung der ägyptischen Chronologie werden die verschiedenen Formen des Wirt-

schaftslebens unter Heranziehung zahlreicher Quellen und Literatur genau durchgesprochen. Folgende Gebiete werden in besonderen Kapiteln behandelt: Ackerbau — Viehzucht, Jagd, Fischfang — Grundbesitz und Bauer — Ausbeutung der Minen und Steinbrüche — verarbeitende Industrien — Organisation der Unternehmen und Stellung der Arbeiter — Umlauf der Güter. Wenn beispielsweise die Getreidearten auf zehn Seiten durchgesprochen werden und die Behandlung von Blei, Messing und Zinn in eigenen Abschnitten durchgeführt wird, so mag das ein Bild von der Ausführlichkeit des gebotenen Materials geben und man wird deshalb gerade diesen Band oft als Nachschlagewerk bei der Bearbeitung von Einzelfragen benutzen können. Lediglich das vorwiegend wieder auf Pirenne fussende vierte Kapitel über den Grundbesitz wird in dieser Form nicht zu halten sein, vor allem in dem, was über die Thinitenzeit und das frühe Alte Reich gesagt ist. Ein 'régime individualiste' (S. 113) und eine 'bourgeoisie fonctionnariste' (S. 114) dürfte damals wohl ebenso wenig zu finden gewesen sein, wie in der Vorzeit demokratisch-liberale Städte (s. o.); auch würden gerade diese Fragen eine genaue philologische Durcharbeitung der Quellen erfordern. — Mit Recht betont Verf. bei der Besprechung der grossen Staatsunternehmen, dass der Bau der Pyramiden nicht als Zwangsarbeit in unserem Sinne zu werten ist, sondern einen Akt des Glaubens bedeutet (S. 229). — Die neu vorgetragene Meinung, dass der Wertmesser *š.t* ursprünglich auf ein wirkliches Zahlungsmittel zurückgeht, das wegen der damit verbundenen Betrugsmöglichkeiten nur kurze Zeit in Gebrauch war, verdient ernste Beachtung, umso mehr als dadurch die Tatsache erklärt werden kann, warum der Aegypter, dem die Einführung eines allgemeinen Wertmessers gelang, nicht die doch einfachere Form wirklichen Geldes angewandt hat. Verf. ist durchaus zuzustimmen, wenn er sagt: 'Attribuer aux vieux Niléens la "géniale" invention d'une monnaie de compte, et les trouver en même temps incapables, pendant des siècles, de la créer matériellement, c'est en définitive bâtir une thèse sur le paradoxe' (S. 262). Auch hier beschliesst wieder eine übersichtliche Zusammenfassung den Band.

Der Genfer Soziologe Duprat hat dem dritten Band ein Vorwort vorangeschickt, dessen Inhalt hier garnicht erwähnenswert wäre, wenn darin nicht eine heute glücklicherweise überholte Anschauung über die Geschichtsforschung zum Ausdruck käme, die ich hier wörtlich anführen möchte, um den Leser sich selbst ein Urteil bilden zu lassen: 'L'historien prépare l'intervention du sociologue qui, en retour, permet à l'historien de sortir du cadre trop étroit des séries interdépendantes de faits établis' (S. xiv). Es sei aber ausdrücklich betont, dass das Werk von Dykmans nicht von diesem engen soziologischen Standpunkt aus geschrieben ist, sondern in fruchtbarer Weise soziologische Fragestellungen bei einer grundsätzlich historischen Arbeitsweise anwendet. — Verf. teilt das Alte Reich, zu dem er auch die Thinitenzeit rechnet, in vier grosse Abschnitte ein: (1) Schaffung der monarchischen Staatsform (Thinitenzeit); (2) die Zeit der grossen memphitischen Bauherren (3. und 4. Dynastie); (3) die Geburt der Oligarchie (5. Dynastie); (4) die Entstehung des Feudalismus. Für jeden dieser Teile beschreibt er die einzelnen Formen und Einrichtungen des staatlichen Lebens, wie sie in der Provinz- und Finanzverwaltung, der Justiz, Armee und Religion zum Ausdruck kommen, und ihre Träger. Durch diese Art des Aufbaus ergeben sich zwangsläufig zahlreiche Wiederholungen, die durch eine straffere Gliederung vielleicht hätten vermieden werden können. Im ganzen gesehen ist es das Ziel des Verfs., das nach einer kurzen Zeit höchster Machtvollkommenheit des Königs allmähliche Aufkommen des für die Reichseinheit verhängnisvollen Feudalismus zu schildern, was ihm auch gelingt, obwohl man manchmal das Gefühl hat, dass weniger mehr gewesen wäre. — Ein Index und eine Bibliographie (wie bereits am Ende des 1. Bandes) beenden das Werk. Die Reichhaltigkeit der gesammelten Literatur ist erstaunlich, wobei umso mehr verwundern muss, dass gerade manche neueren Arbeiten nicht aufgeführt sind, von denen wenigstens einige genannt seien: v. Bissing, *Aegyptische Kunstgeschichte* (1. und 2. Lieferung, die Vorzeit und das A.R. umfassend); Gardiner-Sethe, *Letters to the Dead* (zu Bd. III, S. 181 ff.); Möller, *Die Metallkunst der alten Aegypter* (zu Bd. II, S. 208 ff.); Wolf, *Das ägyptische Kunstgewerbe*, in Bd. IV von Bosserts *Geschichte des Kunstgewerbes* (zu Bd. II, S. 216 u. ö.).

Es kann und soll nicht meine Aufgabe sein, hier ausführlich die kleinen Mängel und Ungenauigkeiten aufzuzeigen, die jeder ägyptologische Leser sofort bemerken wird, dies würde dem Wert des Buches in keiner Weise gerecht werden. Es gilt vielmehr zu betonen, dass nach der meisterhaften Kulturgeschichte von Hermann Kees, in der erstmalig ein Ägyptologe in grossem Stile wirtschaftliche Gesichtspunkte in die Betrachtungsweise einbezieht, hier ein Wirtschaftsgeschichtler seine Maßstäbe und Fragestellungen an den ägyptischen Stoff heranträgt, die von ägyptologischer Seite bei zukünftigen Arbeiten ernstlich aufgegriffen werden sollten und auf diese Weise fruchtbar verwertet werden können. Dies ist das wirkliche Verdienst von Dykmans und jedem Ägyptologen kann die Lektüre seiner Wirtschafts- und Sozialgeschichte nur empfohlen werden.

Royal Sarcophagi of the XVIII Dynasty. By WILLIAM C. HAYES. (Princeton Monographs on Art and Archaeology: Quarto Series, xix.) xi+211 pp.; frontispiece, 25 pls. and 25 figs. in the text. Princeton, 1935.

This book is an admirable specimen of all that a detailed and specialized study can and should be, and Mr. Hayes is to be congratulated on an excellent and most valuable piece of work.

The sarcophagi studied in this book include all the extant sarcophagi of the Dynasty—nine in all—up to Akhenaten and the Aten-period. They form a most interesting and important series, and from the painstaking and extraordinarily detailed examination to which they have been subjected some striking results have been achieved. In the first place, it is shown that there is a regular development in the design and decoration of the sarcophagi. The first monument of the series, Sarcophagus A (of Hatshepsut as Queen Consort to Tuthmosis II), is an imitation of the Middle-Kingdom coffin in wood, and thereafter, while the designers of the sarcophagus did not forget its old use as a 'house', they definitely modified its form so as best to serve and express its primary function of 'the container of a mummy enclosed within a series of anthropoid shells'. It is worth emphasizing that to the reviewer's mind Mr. Hayes has clearly established this point and the order of succession, and this is a matter of the utmost importance, for from it results what is possibly the book's most important and striking contribution—the light it throws on the problem of the Tuthmoside Succession. Mr. Hayes claims, and we think he has justified and proved that claim, that a study of the sarcophagus series proves that the Meyer-Winlock theory is the correct one as opposed to Sethe's theory of the *Thronwirren*.

Many points emerge from this which need not be enumerated in a review, but it may be as well briefly to summarize some of the more important points: (a) the early kings of the dynasty were buried not in stone sarcophagi, but in wooden coffins; (b) the earliest stone sarcophagus is that of Hatshepsut (A) as Queen Consort of Tuthmosis II, (c) therefore, the Cairo sarcophagus of Tuthmosis I (E) cannot have been made by him but was in fact made for his reburial by Tuthmosis III after the death of Hatshepsut; (d) the unscripted sarcophagus (B) found in Tomb 42 in the Valley of the Tombs of the Kings is probably that of Tuthmosis II.

These are but a few of the chief results of this study, but they are sufficient to indicate its importance: it is quite admirable from every aspect.

H. W. FAIRMAN.

The Excavations of the Egyptian University in the Neolithic Site at Maadi. Second Preliminary Report (Season 1932). By OSWALD MENGHIN and MUSTAFA AMER. Cairo, Egyptian University, 1936. 71 pp., 63 pls. Super royal 8vo. P.T. 60.

The work of the second season in the Ma'adi village-site is very fully described in this report. It has obviously been carried out with the same care and thoroughness as that of the first, and it is not the fault of the excavators that no very important additions have been made to our knowledge of the history of the settlement. Four years have elapsed between the excavations and their publication. The delay may be due to financial difficulties, but is probably also, to some extent, caused by the very leisurely methods of the Egyptian Government Press. It is much to be regretted that official regulations insist on the use of the Government Press, which is quite incapable of the dispatch and efficiency necessary for scientific work. In future it might be preferable to condense the text considerably; a tabulated inventory with a description of any new types of objects, and a brief summary of the results are all that is necessary for a preliminary account. Five other reports are now due, as the work has been continued each year. At the present rate of publication we may expect the 1937 report in 1957.

The principal new points are the remains of foetuses buried in pots, and the hippopotamus bone placed vertically in the ground. This last curious find recalls the similar occurrence at Merimda. The plausible explanation that the bone was there used as a step will not serve, however, at Ma'adi. As there is probably a great difference in date between the two sites, it may be that these hippopotamus bones have no common significance.

The presence of a very considerable quantity of 'asphalt' is quite extraordinary and without parallel. No suggestion is made as to the purpose for which this material was collected. It is more than doubtful whether it is really asphalt at all. Mr. A. Lucas has very kindly given me the following note on this subject:

'This material was submitted to Dr. Joseph Gangl, whose method of examination and the results obtained are given in Appendix III of the Ma'adi Report. The result is summarised on p. 50 as follows: "A chemical examination by Dr. Joseph Gangl of Vienna has shown that the material is asphalt very much similar to that produced in Syro-Palestine." Dr. Gangl's analysis was limited to a determination of the solubility of the

material in certain organic solvents; the determination of the ash and the determination of the fact that the material neither softened nor melted at 150° C.

'Professor Menghin submitted a specimen of the material to me and I examined it much in the same manner as Dr. Gangl, limiting myself at first to its general characteristics and behaviour and its solubility in various organic solvents, from the results of which I concluded that the material was an oleo-resin from which the oil of turpentine had been lost, and I reported to this effect to Professor Menghin. I now know, as the result of further experience of such materials, that this method of examination, although necessary and useful as a preliminary measure, must be supplemented by further work, since by itself it gives results that lend themselves to a wrong interpretation. Before a final conclusion can be reached, the material must be saponified, acidified, and extracted with solvents. Such an additional examination was subsequently made, with the result that the material was found to be wholly, or mainly, fat which had become rancid, oxidized, and partly decomposed, a result that would, I am sure, be confirmed by Dr. Gangl on further examination.'

The shells found (p. 51) are very common ornaments in the early predynastic graves; but the single reference, to Petrie, *Amulets*, gives an erroneous impression of rarity. A glance at the tomb registers in *Badarian Civilisation* and *Mostagedda* will show how often shells were strung as necklaces &c. in both Badarian and predynastic times. Twenty-four large pierced *Conus* shells were found in the strange collection of objects 3165 (*Badarian Civilisation*, p. 45). These are, however, possibly part of something like a witch-doctor's outfit. The small unidentified shell (Pl. lxiii, 11) is surely *Ancillaria* sp., which is frequently found in the Badarian and Amratan graves. A river shell with nicked edge was found at Mostagedda (Pl. xl, 47). These flat river-shells (generally *Spatha* or *Mutela*) were used for toilet and other purposes.

With regard to the stone vessels shown on Pl. 1, it seems to the writer that it is unnecessary to regard the basalt cup as a new and specialized type. It is fairly obviously part of a much larger jar which has been broken and then made to serve again after having its broken edge levelled and smoothed. Such large barrel-jars with small feet, generally of basalt, are a well-known predynastic type, and complete examples have, in fact, since been found in the Ma'ādi settlement.

There are one or two criticisms which must be added. It seems a pity that the format of the second report should differ considerably from the first, and that greater care should not have been used in making up the photographic plates. Pl. xxix is arranged with the pottery upside down; Pl. xxxi has one pot right way up and the other reversed; and the scales of the plates vary unnecessarily. But the printing of the illustrations is a vast improvement on that of the first report.

Finally, the authors are to be sincerely congratulated on the work that they are doing, their careful attention to detail, and their orderly presentation of the facts. It is, so far, the only work done by Egyptians in which every attention is paid to minutiae, and which is not seeking for spectacular results. It is much to be hoped that others will follow this valuable example, and help to recover the history which lies buried in many of the most ancient sites in the Delta and Nile Valley.

GUY BRUNTON.

The Rendel Harris Papyri of Woodbrooke College, Birmingham. Edited with Translation and Notes by J. ENOCH POWELL. Cambridge, University Press, 1936. xii+134 pp., 5 pls. and a portrait.

The decipherment and editing of Greek papyri, particularly of a miscellaneous collection containing many fragmentary and defaced texts, is a task which usually requires many months, if not years, of training, even if the editor be a good classical scholar. To tackle successfully such an undertaking as an 'autodidact' and in the midst of other exacting work is an achievement given to few men, and one can but wonder at the *tour de force* which Mr. Powell has accomplished in this volume. That the edition is faultless cannot be claimed; no first edition of such texts ever is. And over and above the imperfections common to every edition of papyri it betrays occasionally its author's comparative inexperience in such work. That he avoids the excess of comment indulged in by some editors is to be counted to him for righteousness, and the provision of translations, which are a welcome feature of the volume, makes possible a further lightening of the commentary; but in not a few cases this asceticism is carried to an extreme, and one wonders at times whether he has really tackled the difficulties of the text before him. There are, too, passages, unmarked by the cautionary dots which indicate uncertainty, in which misreadings are to be suspected. And I have noticed some omissions from the index, and readings in the text which are tacitly corrected in the index but not in the apparatus (*e.g.* 100, 1, *πεῖθου*, left blank in the translation but in the index correctly given, though with

a query, as *πίθος*, an obvious word in the context). The wonder is, however, not that such blemishes occur, but that they are not more numerous.

The papyri were purchased by Dr. Rendel Harris in 1922-3. As they were bought from dealers there is no external evidence as to provenance. The majority, though certainly not all, seem to come from Oxyrhynchus, large quantities of material from which site were on the market in 1922. Literary texts are numerous (nos. 1-60) but for the most part very scrappy. The most important in size is 1, recognized since the volume appeared as part of the lost diatribe of Musonius Rufus, *εἰ πάντα τὰ γινόμενα τέκνα θρεπτέον* (the attribution was made by Mr. Charlesworth). This is distinctly interesting. One or two others have also been identified subsequently; but readers interested in the literary portion of the volume may be referred to the review in *Gnomon* 13 (1937), 577-86, by Bruno Snell.

These literary fragments are well illustrated in the plates, which give the opportunity to check the editor's readings and datings. Most of the latter seem to be correct, but in a few cases doubts arise; thus, 'early first century' seems to me too early for 14. I should assign 7 to the second or even to the third rather than to the first century; perhaps 4 is also placed too early, but the facsimile here is so indistinct that it is impossible to speak with confidence. Since literary texts are so rarely datable save on grounds of script, it is a pity that no facsimile is given of 45, which has a date (A.D. 26-7) on the recto.

The documents as a whole do not rank among the outstanding collections, but they contain two or three important and several noteworthy texts, while in the others there are many individual points of interest. Almost all are of the Roman or Byzantine period, but one is Ptolemaic. This is 61, a decree relating to slaves, dating from the period 176-170 B.C. Slaves are also the subject of 62, a notice concerning runaways. The importance of 64 for municipal organization in the third century is considerable; it is an agreement by which a man nominated by the phylarch of Oxyrhynchus to carry out the *phylacrisia* contracts with his nominator to hand over to him the duties of the office. *Phylacrisia* is a new term; and it is interesting also that the *phylacrites* (if that was his title) though obviously a liturgist, apparently received a salary. There are several puzzling and undeciphered passages in this text; in l. 15 one suspects *Μεσορή* before *τῶν ἐπαγομένων*, but it is difficult to see how it is to be fitted into the context.

No. 68 is an interesting application to be appointed a guardian of minors; and 69 is a complaint, probably to the *archiereus*, that property on which a lien was held by the petitioners has, by an error, been included in other property confiscated by the *ιερατικός λόγος*. There are also some interesting private letters; the most notable, which is a really important addition to our stock of early Christian letters, is 107. Mr. Powell dates it in the third century, with a query; from the facsimile given it seems to date from the beginning of that century and thus to rank among the earliest remains of Christian epistolography. The writer invokes *τῷ πατρὶ θεῷ τῆς ἀληθείας καὶ τῷ παρακλήτῳ πνεύματι* but makes no mention of the Son; and he supplicates for a threefold blessing on his correspondent: *τῷ μὲν σώματι υἰγίαν (sic), τῷ δὲ πνεύματι εὐθυμία(ν), τῇ δὲ ψυχῇ ζῶν αἰώνιον*.

Several of the documents summarized at the end contain points of interest; e.g., in 134 there is new evidence of flight to escape a liturgy.

In conclusion I may add a few suggestions, which are, however, made only tentatively.

61, 2 it seems safe to read *ἀγο*[ρανόμων. 62, 11 a name seems required; qu. 'Ἀρεστᾶι Μένω[νος? (A name 'Ἀρέστης is known.) In l. 15 qu. *τοῖς* [ἄλλοις]? 75, 28 qu. *ἐν αὐτῷ* (in his name)? 78 this tax-receipt is very puzzling, and it is probable that some of the readings require correction. Is *λιβάνου* a place-name (or a misreading of one)? *βοειδίων* is also suspicious; is it really *βοειδίων*? In any case I would suggest that Mr. Powell has misunderstood the document and that the true sense is something like 'paid for the hamlet of Apollo for the imperial dykes and for . . . for two . . . on (the requisition of) the 7th indiction for the inundation of the 8th indiction', i.e. the tax-payer is paying an *adaeratio* on certain demands tendered in one indiction for work in preparation for the next. 80, 33 qu. *πυρὸν* (καθαρόν or sim.) καὶ ἄκριθον? 81 is extremely puzzling. I would suggest that the scribe miscopied from a much corrected draft and put several insertions into the wrong places. 88, 13 qu. *προσενε*[γχο]? 97 has some interesting entries. Is this account concerned with the gymnasium or the public games? In l. 7 qu. *λογοπ*(ράκτη) *βαλ*(αείων)? In l. 11 qu. *ἀπαι*(τητῆ) [or similar] *Καπιτωλιακ(ῶν) ἀγών(ων)* [cf. P. Oslo. 85]? 99, 2 qu. (*ὑπὲρ*) *ἀμπ*(ελικοῦ) *φόρου*? *ηἰολῶ* after *κδ*, which Mr. Powell leaves unexplained in the translation, are the well-known fractions of the *aroura* ($\frac{1}{8} + \frac{1}{16} + \frac{1}{32}$). In l. 4 $\text{L} = \text{ων}$; these are deductions. And *ἐνεβλήθη* means, not 'imposed on' but 'shipped to'. In 102, 2 it is difficult not to believe that the reading is *πρῶτον μὲν* or *πρῶ μὲν πάντων* or something similar. In l. 5 *πᾶσιν* is an equally obvious suggestion, but doubtless Mr. Powell would have read it if it were possible. In l. 7 *ἀπάσασθε*, since it is not corrected in the *apparatus criticus*, seems to be a misprint for *ἀσπ*. 104, 3 qu. *ὑπολαβ[εῖν*

μ]αι ἀπάνθρωπον? 105, 9 surely κα (= και) ἄλλαι, despite the editor's doubts; cf. 107, 8, κα σώμα. 108, 1 Εὐτόλα-
 ρος is a strange name; qu. Εὐτόλμος? 109, 15 is Ἀντιόφου π . . . a muddled writing of Ἀντιόφου πόλει? 112, 5
 almost certainly καταξίωσον. In l. 4 νῦν? In l. 8 there is no need to write ἀ{υ}ξονας; αὔξων is a genuine ortho-
 graphical variant. In l. 10 μηχανία is probably more definite than 'equipment'; μηχανιον is presumably the
 σῆκγῆλ. 126 is certainly a letter. 147, 4 probably a name, Πρωτ(άρχου) or similar. 154, 4 οιδου = ἰδού. 156, 1
 qu. παραντὰ τοῦ δέξασθαι? H. I. BELL.

Antaeopolis. By Sir FLINDERS PETRIE. (British School of Archaeology in Egypt, Vol. li.) London, 1930.
 4°. 16 pp., 28 pls. (1 coloured). 25s.

Die Fürstengräber von Qāw. By H. STECKEWEH, with chapters by G. STEINDORFF, E. KÜHN, and W. WOLF.
 (Veröffentlichungen der Ernst von Sieglin-Expedition, 6. Bd.) Leipzig, 1936. 4°. 72 pp., 31 pls., 7 plans,
 and frontispiece.

These two books are complementary the one of the other. The von Sieglin-Expedition excavated at
 Kāw in 1913, but was not able to continue. Petrie then completed the work in an intensive campaign
 beginning in 1923, lasting some seasons, and covering the whole of the neighbourhood. The results are
 given in Brunton, Petrie, and Gardiner, *Qau and Badari*, I; Brunton, *Qau and Badari*, II, III; Brunton and
 Caton-Thompson, *Badarian Civilisation*; Petrie's above-mentioned book *Antaeopolis*; and Harding's copy of
 the El-Hammāmiyah tombs which appeared in Mackay, Harding and Petrie, *Bahrain and Hemamieh*. Finally
 Brunton took out his own expedition and extended the exploration of the district still farther north. His
 results have just appeared in his volume *Mostagedda*. *Antaeopolis* is Petrie's contribution to that part of the
 site studied in Steckeweh's book.

Owing to circumstances beyond their control the German explorers were obliged to delay publication of
 their results until Petrie's book had appeared, but this had the advantage of enabling them to incorporate
 much of Petrie's results concerning the great tombs. The two books should be read in conjunction, as they
 deal with the same site from very different angles. Thus, Petrie rescued the wrapped-up fossil hippopotamus
 bones from the rubbish of the tombs, and found the great pile of similar bones lower down the slope.
 This was an astonishing discovery, with far-reaching religious significance. Petrie reproduces in colour speci-
 mens of the patterns on the ceiling of Waḥka II and a plan (Pls. i, xi) of their arrangement, while
 Steckeweh gives a photograph of their actual condition (Pl. 9). Petrie's assistant, Greenlees, managed to
 copy some fragments of painting from an inside chamber of Waḥka II (Pls. xxiii-xxviii), which Steckeweh
 was not able to do. Petrie found various objects in the rubbish and cleared the sarcophagus chambers of
 Waḥka II with useful results. He also drew attention to the astonishing resemblance between the plans
 of the Kāw tombs and those of the temples of the Wādi es-Sibū'ah and Gerf Ḥusēn hewn long afterwards
 in Nubia by Ramesses II (Pl. xviii). Petrie deals with the methods by which the tombs were quarried out
 while Steckeweh is concerned with architectural details. In fact this is the main part of his book, and he
 gives valuable reconstructions of the tomb-temples as they probably appeared when finished (Frontisp.,
 Pl. 19, and plans which follow the Pls.). So much for the ground covered in common. Besides this, Petrie
 deals with the quarries in the neighbourhood, and the methods of extracting the blocks and of getting them
 down to the level ground. A large part of Steckeweh's publication is taken up with Kühn and Wolf's chapter
 on the Graeco-Roman burials with which the ground about the tombs of Ibu and Waḥka II was riddled.
 Finally Steindorff works over the objects, mostly inscribed pieces, which can be connected with the Kāw
 nomarchs, from wherever they may have come and in whatever museum they may now be resting. The
 pieces have come not only from Kāw itself, but from Abydos and Memphis. The material from the original
 excavation of Kāw, that of Schiaparelli in the season of 1905-6, lies in the Turin Museum. As it has not
 otherwise been published, Steindorff's study is probably nearly all that can now be made of it. But still it
 is to be hoped that the Museum will soon see its way to publish it fully, along with much else of value in its
 possession that has not yet been laid before the world. Steindorff embodies his results in a valuable intro-
 duction dealing with what is known of the district, its history, geography, and religion.

The chronological sequence of the great tombs as (1) Waḥka I, (2) Ibu, (3) Waḥka II, was established by
 Petrie and is accepted by Steckeweh and Steindorff, although Petrie had no direct evidence with which
 to date them. The cemeteries show that the prosperity of Kāw was great all through the First Intermediate
 Period (Brunton, and others, *op. cit.*, I, 75, 76), but that this came to an end early in Dyn. 12 (Brunton,
op. cit., III, 2). In view of this and of the importance of the neighbouring Asyūt in Dyns. 9 and 10, it seemed

that the great tombs of Kāw must necessarily belong to that period also. Hence, it was to this date that Petrie assigned them. Now, however, Steindorff's far-flung search has produced a stela in the Stockholm Museum which shows conclusively that Waḥka II lived in the reign of Amenemḥet III. Hence, the Senusret after whom Waḥka's son was named was probably Senusret III, and Waḥka I no doubt lived in the reign of Amenemḥet II. The stela comes from Abydos, but belongs to a 'Nomarch and Overseer of the Prophets, Waḥka, begotten of Nakht, justified'. These are the titles of Waḥka II, and a Nakht had been nomarch at Kāw at this time, for among Schiaparelli's finds is a piece of his coffin. It is curious that Waḥka gives his father no titles on the Abydos stela.

The reviewer would add that in view of the new light on the dating a very different story is unfolded from that which had been anticipated. The splendid tomb-temples of the nomarchs are not contemporary with the welfare of the middle and lower classes. On the contrary they begin, as the smaller graves show, at the time of the depopulation or impoverishment of the district. Presumably, therefore, the nomarchs absorbed all the local wealth and energy in their enterprises and finally ruined the district. If so, the last and greatest tomb-temple, that of Waḥka II, stands, like Versailles, a magnificent monument to the splendour of the ruler and the ruin of the country.

The plans of these tombs bear no resemblance to those of Beni Ḥasan, Mēr, or El-Bershah. Moreover, they are quite different from that of the tomb-temple of Mentjuḥotpe at Dēr el-Baḥri, in spite of some external resemblance. Actually all that they have in common is the general principle of a staircase going up to a pillared platform. Astonishing though it may be, their plans are extraordinarily like those of Ramesses II's rock-cut temples at Wādi es Sibū'ah and Gerf Ḥusēn in Nubia. Though it may be hard to accept Petrie's historical conclusions, here is certainly a question which demands consideration. It does not seem to have been noticed, however, that the Kāw tombs are also very similar in plan to that of Hapdjefi at Asyūt. Petrie's plate should be compared with the plan in Porter-Moss, *Top. Bibl.*, iv, 260. It may be added that there are clear signs of a large courtyard in front of Hapdjefi's tomb, and a stairway or causeway must have led up to it originally. It is from one of the side sanctuaries that the passage descends to the burial chamber in Hapdjefi's tomb, exactly as in the Kāw tombs. On the same page of the *Top. Bibl.* there is a plan of the 'Salkhānah' tomb, also at Asyūt and still vaster than Hapdjefi's. The plan of this tomb also has something in common with those at Kāw. The date of these two Asyūt tombs is problematical; they are quite unlike the Ninth- to Tenth-Dynasty tombs there of Ekhtay ('Khety') and Tefibi. Yet Hapdjefi's is earlier than Senusret I, for the inscription containing this king's names is a palimpsest (Griffith, *Siūt and Dēr Rifeh*, Pl. 4, first marginal note). The Salkhānah tomb has an inscription containing the name of Amenemḥet II (see Moss in *JEA* 19, 33).

The cults at Kāw were most peculiar. Hippopotamus bones, mostly fossilized, had been collected from far and near, and made into a pile; others had been wrapped up and deposited in the graves as sacred relics. The hippopotamus is of course sacred to Seth, and this is not the only evidence that his cult was strong here. As if this were not queer enough, two of the nomarchs, Ibu and Waḥka II, became demigods after their death: they are either associated with the usual gods, or addressed alone, on several *ḥtp di nsw* formulae from the site. One knows of wise men of an early period, like Imḥōtep, who were deified long afterwards, but the deification of two members of a family shortly after their death must be extremely rare. The mother of both these two demigods was called *Ḥtpwy* 'The Two Peaceful Ones (??)', a name common at this time in the district of Kāw. The god of the nome was a combination of 'The two Gods' (Seth and Horus), who fought there; to a finish according to a late story. Can *Ḥtpwy* have reference to this? Waḥka II seems to have paid homage to Ptaḥ of Memphis: offerings are made to him in one of the scenes of the tomb, and an altar was dedicated to him at Memphis itself by a Waḥka who had the same titles as Waḥka II of Kāw.

The devotion of the district to Seth may account for the fact that the tombs have been perhaps more completely smashed and wrecked than any others in Egypt, the pieces having indeed been apparently carried away, for the various expeditions only found scraps. There had been numbers of large statues in each of the tombs, the walls of some of the courts had been faced with sculptured slabs, and other rooms had been painted with scenes. Yet of all this only a few basketfuls now remain.

If there were two burial chambers, the western was evidently the more important. Petrie found scraps of Waḥka I's coffin in his western chamber, and Schiaparelli found Ibu's coffin likewise in his western chamber. Strangely enough the largest of all the tombs, that of Waḥka II, had only one burial chamber, and as that was on the eastern side the nomarch had perforce to be buried there.

In his conclusion Steckeweh has some valuable remarks on the elements contributed to architecture by Lower and Upper Egypt respectively. The 'Vorhalle' (small room with steps in it in front of the great

courtyard, cf. Plan vii) of Waḥka I is copied from a pyramid-temple, in Ibu it is only indicated, and Waḥka II gives it up entirely. Ibu introduced pylons, with which neither the 'Vorhalle' nor the roofed causeway can be reconciled. Hence, Steckeweh says, Waḥka II has an open causeway, though on Pl. 19 he reconstructs it with a roof. Pylon and open approach first appear in the temple of Mentjuhotpe at Dēr el-Baḥri and in the tombs at Kāw; they are definitely Upper-Egyptian elements. These buildings were intended to be appreciated from the outside, as well as from the inside. But in Lower-Egyptian architecture there is no imposing exterior, and the approach is by a roofed causeway, so that the visitor sees nothing of the temple until he is inside it.

Steckeweh supposes the fishes and plant (Pl. 15, c and p. 24) to be Red Sea fishes and coral, and on this assumption he bases a statement that the scene clearly shows that Ibu ruled as far as the Red Sea, and that it commemorates a visit there. But in what way do the fishes or the plant differ from those common in boating and fishing scenes in the Nile swamps? For instance *El Bersheh*, II, Pl. xvi gives just such a plant with a papyrus-clump. The fish at Kāw is the one that is usually speared, and that swims in most scenes of aquatic life. The one behind it is the *ḳarmūt* of the Nile, which is shown in the scenes only less commonly than the other.

Steckeweh remarks that Waḥka II's painted ceiling includes several patterns unknown hitherto, and goes on to mention the palmette and spiral (*Antaeopolis*, Pl. i, middle of top row). Actually this pattern occurs a number of times and raises some interesting problems, which the reviewer hopes to take up some day. He believes it to be found in Hapdjefi's tomb at Asyūt; if so, one more point of similarity exists between this tomb and those of Kāw.

G. A. WAINWRIGHT.

Individuum und Gemeinschaft in der ägyptischen Kultur. By WALTHER WOLF. (Leipziger Ägyptologische Studien, Heft 1.) Glückstadt, J. J. Augustin, 1935. 8vo. 30 pp., 2 pls., 3 illusts. Rm. 3.

The thesis of this short but thought-provoking discussion is that the self-conscious individual played no part in the development of Egyptian culture, at least until Dyn. 18. Dealing first with Egyptian art, Professor Wolf shows that its peculiarities can only be explained on the hypothesis that the artist was completely determined by tradition, did not freely represent what he saw. Not until the New Kingdom do three-quarter-face representations, the first signs of the free creative artist, appear. The same holds good of religion. The sense of sin and the desire for reconciliation, without which religion cannot be personal, are not found in the earlier period. They only appear when the traditional state religion is breaking down, the structure of society is changing, and the king is an individual with heterodox ideas of his own. The arguments are cogently worked out in this short study, and it is left to the reader to test their truth further. They could certainly be applied with equal force to Egyptian ideas about morality, changing from the emphasis on obedience to traditional rules in Ptahhotpe to the more general advice about development of character in Amenemope.

A. N. DAKIN.

The following works have also been received:

Excavations at the Tepe Hissar Damghan. By ERICH F. SCHMIDT. (Publications of the Iranian Section of the University Museum.) Philadelphia, Univ. of Pennsylvania Press, 1937. 4to. xxi+478 pp., 79 illusts. 67s. 6d.

The Last Chapters of Enoch in Greek. By CAMPBELL BONNER. (Studies and Documents, VIII.) London, Christophers, 1937. 8vo. 106 pp., 2 pls. 15s.

The Origins of Early Semitic Ritual. By S. H. HOOKE. (The Schweich Lectures of the British Academy, 1935.) London, Humphrey Milford, 1938. 8vo. x+74 pp. 6s.

Scribes and Correctors of the Codex Sinaiticus. By H. J. M. MILNE and T. C. SKEAT. London, British Museum, 1938. 4to. xii+112 pp., 43 pls., 23 figs. 32s. 6d.

The Stone Age of Carmel: Excavations at the Wady El-Mughara. Vol. I. By D. A. E. GARROD and D. M. A. BATE. London, Clarendon Press, 1937. 4to. x+264 pp., 44 pls. 42s.

THE SO-CALLED OMPHALOS OF NAPATA

BY GEORG STEINDORFF

DURING his excavations of the sanctuaries of Napata at Gebel Barkal, the sacred mountain of the Ethiopians, Reisner found inside the great Temple of Amūn (B 503) 'a conical sandstone block covered with sculptured necklaces, etc.', which Griffith, in a preliminary communication in *JEA* 3, 221, compared with the celebrated umbilicus-like figure of the god of the Oasis of Ammon described by Quintus Curtius. In *JEA* 3, 255, Griffith published a sketch made from a photograph and a brief description of this remarkable monument. 'It is of sandstone and evidently of moderate size. Its conical shape is precisely that of the omphalos at the Oracle of Delphi.' He further suggested that this stone was connected with a Nubian oracle at Napata, and that the Omphalos idea was taken over from Delphi. Griffith's ingenious

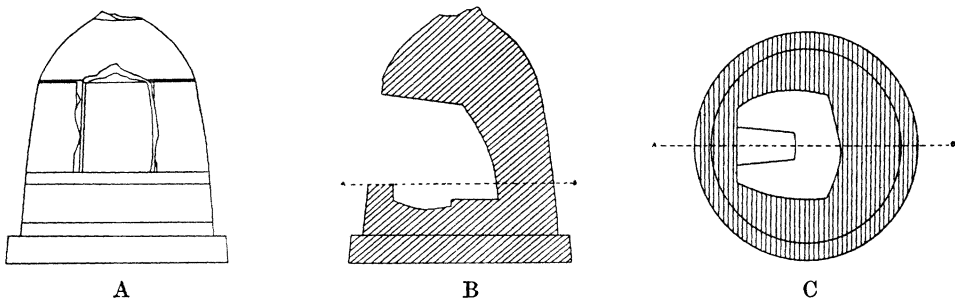

FIG. 1.

hypothesis was then followed up by Wainwright, who, in *Ann. Serv.* 28, 184, compared the monument with the Ammon fetish of Sīwah and similar Egyptian images, and suggested that its shape was derived from that of a meteorite. I myself expressed my agreement with Griffith in *ZAS* 69, 23, and from the close connexion between the Ethiopian and the Libyan (Sīwah) fetish I deduced a close relationship between the oracle of Ammon in Sīwah and the one presumed to have existed in Napata.

The monument found by Reisner is now in the Museum of Fine Arts in Boston, and bears the Inventory No. 21.9234. It was there that I saw it in May 1937, when I came to a conclusion about it which is fundamentally different from that of Griffith, who probably never saw the original. At my request my friend Mr. Dows Dunham, Associate Curator of the Egyptian Department of the Museum of Fine Arts, very kindly had several good photographs of the stone taken, which he has given me permission to publish (Pl. vii). Besides this Miss Betty Eaton prepared an exact drawing in natural size and some sketches, and gave this important material to me. I owe to her and Mr. Dunham a debt of deep gratitude for their unselfish assistance. On the basis of this abundant and reliable material, along with the notes which I made on the spot, I propose to discuss this important object once more.

This monument, made of Nubian sandstone, is beehive-shaped, and rests on a slightly projecting base. Its height is 0.61 m., the diameter of the base 0.58 m.; the greatest diameter of the part above the base is 0.52 m.

At the front (Pl. vii, 1; Fig. 1, A) there is a door-like opening of about 0.24 by 0.20 m.,



1

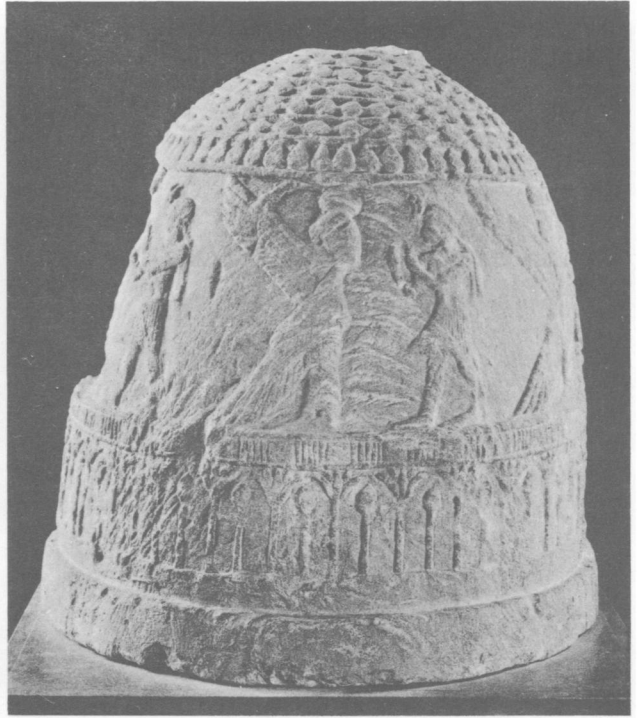

2



3



4

THE SO-CALLED OMPHALOS OF NAPATA.

and in the interior an irregular rectangular hollow space, in the bottom of which there is a depression about 0.085 by 0.13 m. (see Fig. 1, B, C). I presume that in this latter the base of a small image of a god was originally set. The top of the object is worn away, so that it is impossible to be certain what its form was; possibly it was a round knob.

The exterior surface of the monument is adorned with reliefs in a pronounced Meroitic style. The ornamentation is divided into three parallel horizontal registers (*cf.* Fig. 2), which I will describe in detail.

A. TOP REGISTER. This shows an ornament of six different necklaces of round, barrel-shaped, and drop-like beads (*cf.* Fig. 2, A).

B. MIDDLE REGISTER (Fig. 2, A, B). Bounded below by an ornamented band, reminding us of the common Egyptian 'border of coloured rectangles' (*cf.* Petrie, *Egn. Decorative Art*, Fig. 196), and interrupted by the above-mentioned opening, this displays two processions of figures exactly corresponding to one another and moving towards the door:

I. *Procession to the right of the door.* This comprises four figures:



(1) The king, in a short, richly pleated kilt, down the back of which hangs the usual tail; his coiffure consists of short ringlets and the diadem often worn by Ethiopian kings, adorned in front with two uraei, the one apparently bearing the Upper-Egyptian, the other the Lower-Egyptian crown (or are these objects feathers?), while from the rear of the diadem two long ribbons hang down. The king lifts both hands in adoration, obviously addressed to the divine image which was set up in the interior.

(2) A lion-headed goddess, the sun-disk on her head; with her two outstretched wing-arms—the one hand holds a feather β, the symbol of truth, the other clings fast to the wing—she protects the king as he walks before her; how we are to understand this protection and the position of the wings numerous statues show us, *cf.* the stone and bronze figures of Isis protecting Osiris, Daressy, *Statues de divinités (CCG)*, Pl. lix, Nos. 39271, 39272; Pl. xlv, No. 38891 (without Osiris); Roeder, *Aegyptische Bronzewecke*, Pl. 17, *c, d*, with text, § 131.

(3) A second figure of the king in the same dress (except that the uraei on the diadem here bear sun-disks) and posture as No. 1.

(4) A winged, human-headed goddess, protecting the king just like No. 2; she is however different from No. 2 inasmuch as she wears a short wig and on her forehead a uraeus, and there is no feather in her right hand.

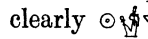
II. *Procession to the left of the door*, as I, four figures: (1) the king as in the procession on the right; (2) winged, human-headed goddess with short wig one (hand holding a feather, as I, 4); (3) the king as I, 1; (4) winged, lion-headed goddess, as I, 2.

At the point in this register diametrically opposite to the opening are the two chief names of the Ethiopian king in cartouches surmounted by . The one name, to the left, can be read clearly . This is, of course, the prenomen of Amenophis III, which was appropriated by two Ethiopian kings: Nebmaṣrē I = Amanitenmēmize¹ who is buried in the Bagarawiyah pyramid N, XVII (= Lepsius A 38), and Nebmaṣrē II = Amanikhanēwēl (?) who is buried in the pyramid N, XVIII. The second name, on the right, is unfortunately partly obliterated. Griffith (*JE A 3, 255*) read it as  'Mnḥnēwēl (?)', i.e. *Amani-Khanēwēl (?)*. I was unable to recognize these signs distinctly in the unfavourable light by which I saw the inscription. Later Griffith's reading was collated in a good light by Mr. Dunham and Miss Eaton. Miss Eaton writes as follows on the results of

¹ , Lepsius, *Dkm.*, v, 51, *a, b*.

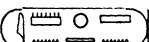
the examination: 'Mr. Dunham and I puzzled a long time over the cartouches. . . . The inscription is anything but clear and requires the eye of faith on one or two spots.' Dunham is sceptical as to Griffith's reading: 'From my examination of the original in varying lightings I don't think this possible.' His reading in place of Griffith's is shown in Fig. 3, and gives the name *Mani-Hanaqermē* (?) or *Hataqermē* (??). 'The Hieroglyphic (Egyptian, debased type) as given in the chapel of Lepsius's No. 39 = Reisner's Pyramid N, XVIII (Leps., *Dkm.*, v, 51, c = *Textbd.* v, 319) is ', adds Dunham.



*CONCERNABLY 
FIG. 3.

C. BOTTOM REGISTER. This is decorated with a design occurring elsewhere at the bottoms of walls (*cf.* Petrie, *Egn. Decorative Art*, Fig. 132): alternate large nymphaea-flowers and small nymphaea-buds on vertical stalks.

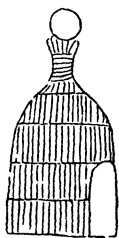

FIG. 4.

Now, is the beehive-shaped monument from Napata here described a cult-object, resembling an umbilicus, an *ὀμφαλος*, as has been assumed since Griffith's discussion? I believe that this question must be answered unconditionally in the negative. Rather, as must already be clear from my description, it is a small shrine containing a little image of a god and presumably set up in the temple as a dedicatory offering of the Ethiopian king. Just as in Egypt it was usual to give such shrines the form of small houses or temples with pillars, torus-mouldings, and cornices (Schäfer, *Propyläen-Kunstgeschichte*, 405, 2. 3), so in Ethiopia they were occasionally formed after the pattern of an African house—a circular hut made of mats or wickerwork, such as is still in use to-day among the Bantu peoples and, as Borchardt has shown (*ZÄS* 73, 118 f.), among the Tuaregs. How such a Sudanese hut looked in antiquity may be seen from a bronze bowl found

in Karanög, the so-called 'Queen's Bowl' (Woolley-MacIver, *Karanög*, 59): 'A small round hut formed of withies planted in the ground and tied together at the top, strengthened at intervals by four horizontal bands; it is surmounted by the sun-disk' (Fig. 4). Compare also the picture of such a mat-hut on a protodynastic ivory tablet from Abydos (Petrie, *Royal Tombs*, II, Pl. 4), referred to by Borchardt, *loc. cit.* The natives of Pwenet also had wickerwork huts with hemispherical tops, *cf.* Naville, *Deir el Bahari*, III, Pls. 69-71; Schäfer, *op. cit.*, 348, 1.

The construction of such a hut is not reproduced in our chapel. Instead, the exterior has been decorated with ornaments and pictures corresponding to the sacred purpose of the monument. But the hut-form with the door is unmistakable. In view of this, the comparison with an *ὀμφαλος* must be given up, and with it also any theories involving the cult-object of the Oasis of Ammon or the sacred Omphalos of Delphi.

**PRELIMINARY REPORT ON THE EXCAVATIONS AT
SESEBI (SUDLA) AND 'AMĀRAH WEST, ANGLO-
EGYPTIAN SUDAN, 1937-8**

BY H. W. FAIRMAN

THE main objective of the Society's work in the Northern Province of the Sudan during the winter of 1937-8 was the completion of the excavation of the site known to Egyptologists as Sesebi (Pl. viii). This task did not prove to be a long one, and, when the work was completed, the men were moved some 65 miles northwards and 12 days were spent in testing and exploring an ancient town site at 'Amārah West.

The staff throughout the season was composed of Mr. E. D. Bell, who was responsible for the photography and surveying, Mr. I. E. S. Edwards, of the Department of Egyptian and Assyrian Antiquities in the British Museum, and Mr. H. W. Fairman. It was a source of very great regret to all of us that at the very last moment circumstances prevented Professor A. M. Blackman from accompanying us as Director: we greatly missed the benefit of his experience and guidance.

We owe a very deep debt of gratitude to all those who made our work possible: to the Brooklyn Museum of Fine Arts and Professor Capart, to the Musée du Louvre, to Mr. O. C. Raphael, whose generous donation enabled us to purchase a complete Leica outfit which was largely responsible for the greatly improved photographic record, and to the Trustees of the British Museum for permitting Mr. Edwards to accompany us.

To the officials of the Sudan Government our indebtedness is great: in particular to Mr. G. W. Grabham, the Acting Conservator of Antiquities, for his never-failing assistance and many personal kindnesses, to Mr. A. C. Walker, the District Commissioner, and to Mr. L. M. Buchanan, the Assistant District Commissioner at Wadi Ḥalfa.

Sesebi (Sudla)

Some words are necessary in explanation of the manner in which we refer to the site. Egyptologists have become accustomed to speak of 'Sesebi', but in actual fact no such name or place exists. The nearest village to the ancient town is that of Sese, nestling below Gebel Sese with the ruins of its mediaeval fortress. The district in which the town is situated is known as Sudla, the name which is given on the official maps, but the local inhabitants occasionally speak of Gami.¹ The early travellers refer to the site as Sesech² or Sescé.³ Modern writers, while occasionally using Sese, have shown a preference, since the time of Lepsius, for Sesebi.

We have so far found no explanation for Sesebi. The 'king' of the Mahas, the Sheikh 'Abdel 'Azīz Zibīr, told me that according to local tradition the site was founded by King Sesaba, but this explanation is obviously inadequate. Mr. A. J. Arkell has suggested that perhaps the mistake was occasioned by a misunderstanding of the locative case, **Sese-bi*,

¹ I have heard this name only occasionally. It appears to be used specifically of the southern part of Sudla.

² Caillaud, *Voyage à Méroé*, I, 388.

³ Hoskins, *Travels in Ethiopia*. Hoskins did not visit the site, but mentions it.

'at Sese', but I have been unable to find a particle *-bi* in any of the Nubian grammars and dictionaries. Since the term has now so general a use, it would be confusing to drop Sesebi altogether, and so we have decided to combine the false with the true in the form of 'Sesebi (Sudla)'.

The first task was to complete the clearance of the western section of the town. The strip alongside the west wall produced little of interest in the way of buildings or objects: in the south-west corner was a group of small and late houses, and further northwards lay three very large magazines, which also appear to be late, or, at least, subsequent to the original foundation of the town. From these magazines, however, came a very pleasing and typically 'Amarnah piece in the shape of a relief of a princess on a fragment of black granite (Pl. x, 1). At the same time a closer study was made of the West Gate and its approach than had been possible the previous season. The approach from the east (from the interior of the town) seems to have been flanked by four stone bases, which were presumably for statues or offerings. A somewhat similar arrangement was found a few years ago in the approach to the smaller temple (the Ḥat-Aten) at 'Amarnah. A study of the drainage system in the gate proved that it could hardly have served for the general drainage of the town, but must have been designed for the gate alone. It seems clear that the town was liable to heavy rainfall, which might be absorbed by the ground in the town but not by the stonework of the gate itself.¹ None of the gates of the town were as imposing as the west one, and it seems that this must have been the main entrance. This is an unexpected discovery, but later in the season a similar arrangement was noted at 'Amārah West, where the main entrance to the Temple lay on the side most remote from the river (see below, p. 155).

In the centre of the town we hoped to find some large dwelling-houses, but excavation soon showed that the very solid walls owed their pretentious appearance to rebuilding, many of the walls having been doubled. The area has suffered considerable modification. Originally, it is clear, there was a block of very simple and small buildings immediately to the south of the block of magazines excavated last year. These buildings can hardly have been ordinary houses, and it seems best to regard them as administrative offices. This administrative block was formerly separated from the dwelling-houses by a wide and imposing street which led directly to the West Gate. Later, however, the offices themselves were greatly altered, and additional rooms were built in the street. At the same time a small drainage system, of which we found some signs, was installed.

The whole of the eastern section of the town was largely barren, and only at the southern end were any signs of houses found. It is almost certain that this section of the town was never fully developed, very probably because it lay on a slope and offered difficulties in the way of levelling. The houses were badly damaged, some had been destroyed by fire, and all had been largely rebuilt. However, the cellars, which are so common a feature at Sesebi, provided many objects of interest, including a sandstone statuette of somewhat uncommon type which is apparently a funerary figure,² three small stelae of no great importance, many scarabs and other small objects, and some Mycenaean sherds (all LH. IIIa).³

In the south-east corner we found a most interesting complex of buildings. Before excavation started all that could be seen was a tall mound of debris in which were two brick walls (Pl. ix, 1). Excavation soon revealed at the top two late tombs (robbed), and below

¹ The fact that it was necessary to provide for the drainage of the gates suggests that they were not roofed over.

² Cf. Boreux, *À propos de quelques bustes égyptiens* in *Griffith Studies*, 395-401.

³ In passing it may be mentioned that Mr. J. D. S. Pendlebury considers one of the Mycenaean sherds found in the 1936-7 excavations (No. 337) to be LH. IIIb.

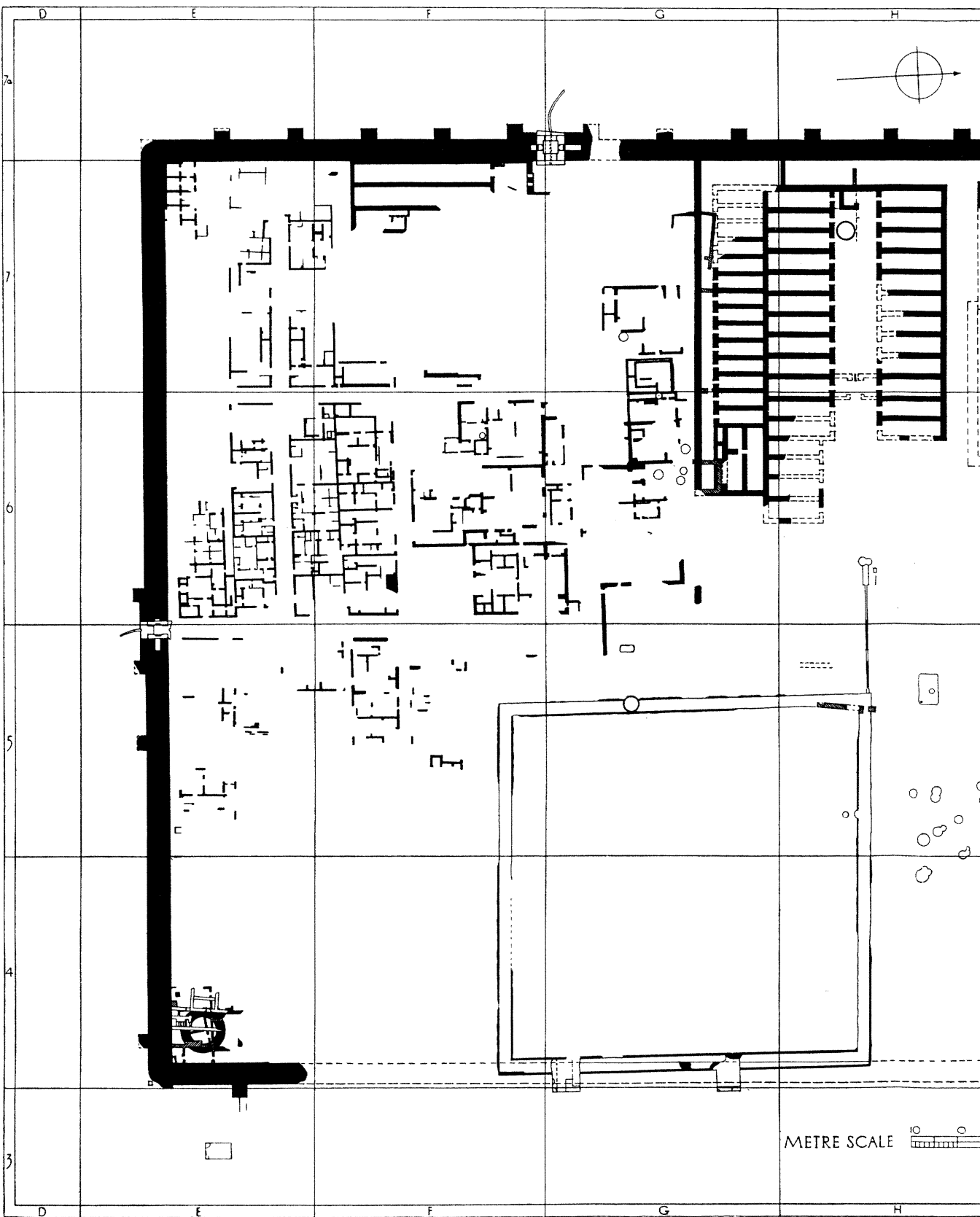

Plan of the Town.

EXCAVATIONS AT SESEBI (SUDLA), 1937-8.

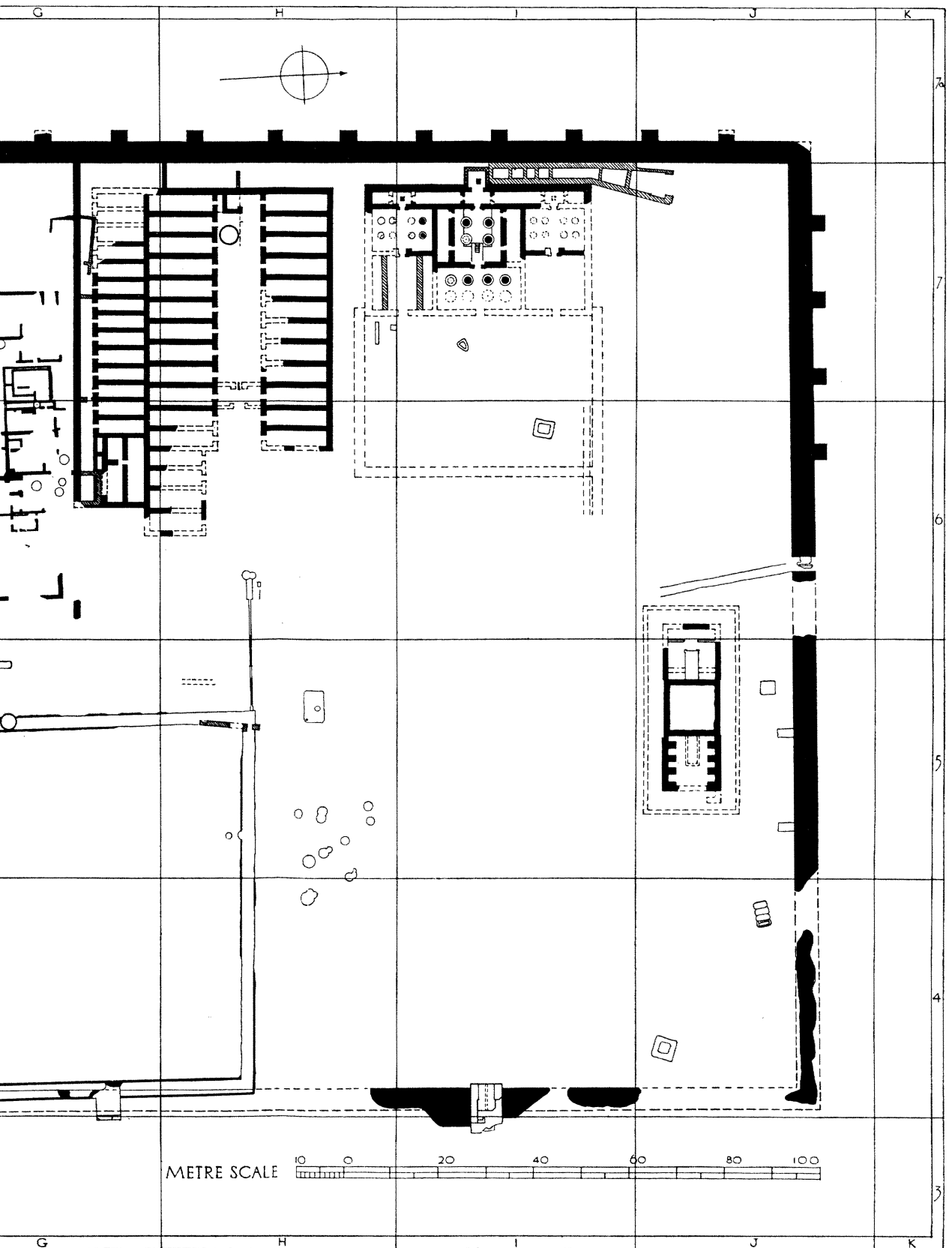

Plan of the Town.

these gradually emerged the ruins of a large house (E. 4. 1: Pl. ix, 2). This house must have been built after the reign of Sethōs I, since a block bearing the cartouches of that king acted as the threshold to one of the rooms (Pl. ix, 3). It was not long, however, before it became clear that another house lay below this (E. 4. 4). One of the rooms in E. 4. 4 had been used as a work-room in which quartz had been crushed and the floor was several centimetres deep in minute chips and dust, amidst which were several larger stones which may have been the bases on which the quartz was crushed. Below this house were found yet other remains—an enormous and massive brick construction (E. 4. 5: see Pl. ix, 3; E. 4. 1 & 5, E. 4. 4 having been removed). It was necessary to remove all the walls of the earlier houses, and it was then found that E. 4. 5 was a circular construction standing in a small courtyard. Our first theory that this was the town well was soon disproved by the discovery that the building was divided into three compartments by a T-shaped wall (Pl. ix, 4). There are no steps into and no means of entering E. 4. 5 and its exact function is still a mystery.

North of this interesting complex of buildings lay the mysterious brick-lined Trench which was partly excavated last season. Our work showed that the square of land enclosed by the Trench contained no complete buildings, and, apart from two isolated and broken walls, bore no signs of occupation. The Trench is lined with brick in its north, south, and west sections, but on the east its sides are reinforced with rough stone-work (Pl. x, 2), and here the Trench seems to go partly under the east wall of the town, a fact which may explain the stone reinforcement. It is impossible that this trench should ever have acted as a moat, for the slope of the ground is such that to have kept even an inch of standing water in the western section would have involved the flooding of nearly half the town. Possibly it was intended as a protection for the early settlers and workers before the town wall was completed. Later, however, the east wall of the town was breached, two additional stone gateways were made, and ramps were thrown across the Trench. Mr. Edwards has suggested that possibly the area enclosed by the Trench was intended for use as a shelter for cattle, but it seems rather unnecessary to make two stone gateways in a perfectly good wall just for cattle.

In later times it is quite possible that the Trench was used for drainage purposes,¹ for at the north-west corner we found a stone drainage channel. This water channel, however, is itself somewhat of a problem, for the central section is higher than either end, and while a small section of it falls towards the Trench, in the greater part of it the natural flow of water must have been away from the Trench towards a small, rectangular stone construction. This stone construction must presumably have been the foundation of a stand or tank, and apparently this tank must have stood at a sufficient height to force the water flowing from it to surmount the slight rise between the tank and the Trench. This is offered only as a tentative suggestion, for the existing remains are exceedingly scanty, and a tank in this part of the town seems unnecessary.

In the course of the season two more sets of intact Foundation Deposits were found. The first lay exactly under the south-east corner of the town wall. The two small pits were covered by a large slab of stone, the underside of which was inscribed with the cartouches of Amenophis IV, whose name also appeared on the faience plaque, the scarab and the scaraboids which were found in the pits. It is clear from this that not merely the Temple, but the whole town was the work of Amenophis IV.

Two isolated and intact pits, the least profitable of all the Foundation Deposits, were found in the centre of the town. They were not in connexion with any building, for the area

¹ It is certain that the Trench ceased to be regarded merely as a barrier, for in the higher, western section (the driest part) two or three corn-bins and granaries were added later.

in which they were found was devoid of the slightest traces of houses, but we noticed that they were situated on the line of the southern wall of the Temple, and it must be presumed that other pits, which have since been swept away by floods, were once made on the line of the outer walls of the Temple.

Finally, we completed the record of the Temple. In the north wall of the sanctuary of the central shrine, which we suspect was added by Sethōs I, we found an enormous re-used block, which, as it appeared to be inscribed, we decided to remove. We then found that it depicted the head and shoulders either of Amūn, or of a royal person wearing the headdress of that god, and that it had once formed part of a door. A careful examination of the Temple showed that this block could not have come from any of the doorways to be seen in the present ground-plan of the Temple. It is therefore very probable not only that this block must have been worked during the pre-Aten period of Akhenaten's reign, but that the Temple must have suffered more radical alteration under Sethōs I than we had suspected. Further evidence of modification of the ground-plan of the Temple was forthcoming when careful brushing of the pavement revealed the mason's marks for a small altar, or basis for a boat-shrine, between the central columns of the southern Temple.

'Amārah West

The site of 'Amārah lies some 115 miles south of Wadi Ḥalfa. On the east bank once stood a Meroitic temple of which only the slightest traces remain.¹ On the west bank the ancient remains are more extensive, and we found a large and well-preserved town, and cemeteries of the New Kingdom and X-Group period. It should be pointed out that, since the Nile at this point flows almost exactly due east and west, 'Amārah 'West' stands on the *north* bank of the river. However, one conventionally regards the Nile as flowing from south to north, and it seems well in this report to describe the various parts of the site by the local and not by the true compass points: thus 'north' at 'Amārah West is local north, but true east.²

The ancient town is situated on a large mound (Pl. x, 3) close to the river. At present there are few indications of ancient occupation, for sand has drifted over all walls, and there are scarcely any objects or even sherds to be noted on the surface. It is the drifting of the sand that has contributed so largely to the preservation of the site, and causes us to entertain high hopes of successful excavations. Our tests showed that the accumulation of debris and sand was 2 m. deep on an average, the upper stratum of clean, wind-blown sand being a metre deep. The precise extent of the town is still uncertain, for the accumulation was too deep to permit us to find the outer wall of the town in the short time at our disposal, but it is certainly not smaller than Sesebi (Sudla), *i.e.* some 200 × 300 m., and it may be slightly bigger. The site, however, is in an infinitely better state of preservation, and will take much longer to clear.

The aim of our short exploration was not to dig cleanly or deeply, but simply to discover the nature and prospects of the site. We succeeded in locating the Temple, and a few days' scratching laid bare the whole circuit of its walls, which are covered on both sides with reliefs and inscriptions. On the exterior the scenes are on a large scale, but the figures of Amen-Rē', Horus, Min, Ptaḥ, and Ramesses II, among others, are preserved only from just above the knees. The interior of the Temple, as tests in the Sanctuary showed, is better preserved, and it is reasonably certain that the whole of the lower register of scenes is com-

¹ See Kirwan's note in *JEA* 22, 101.

² In this report the local bearing is given thus, 'north', and the true compass point is added in brackets.

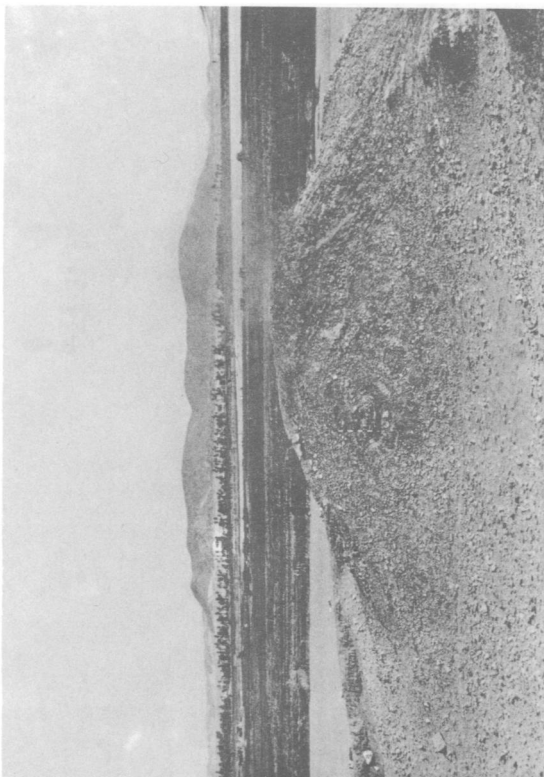

1. The mound (E.4.1, 4 & 5) before excavation.

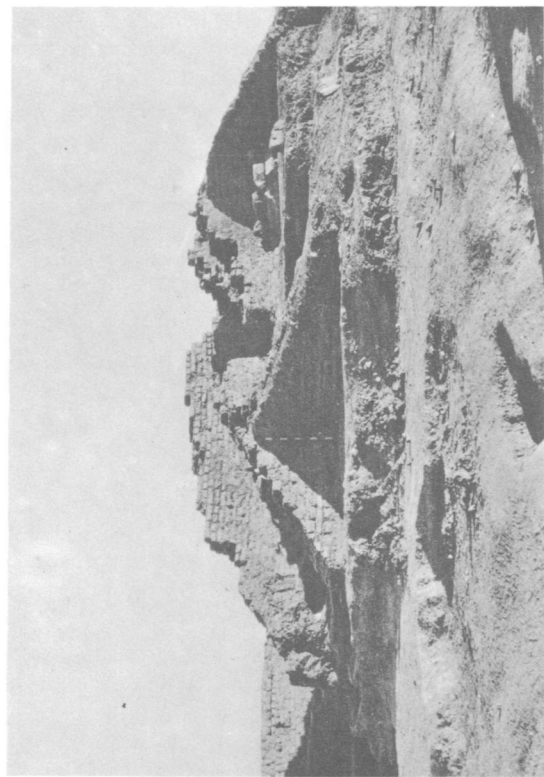

2. E.4.1 : first stage.

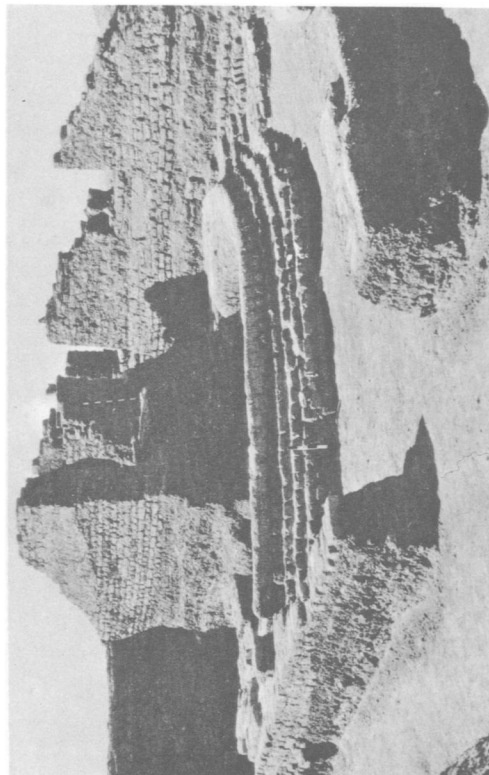

3. E.4.1 & 5 (E.4.4 removed).

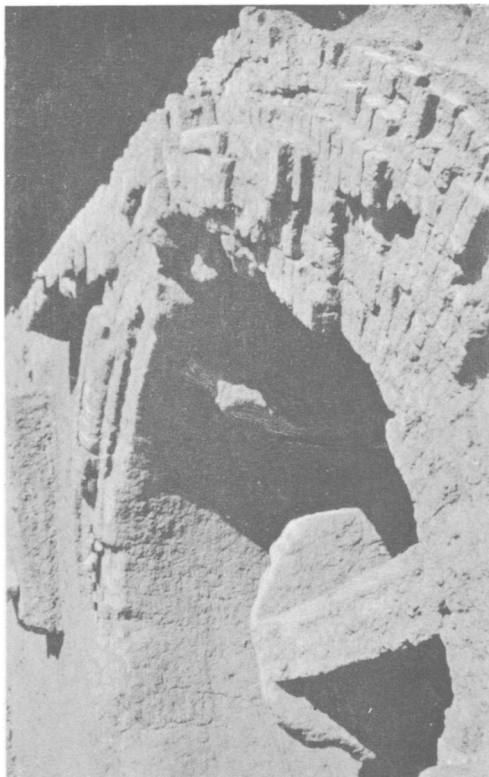

4. E.4.5 final stage.

EXCAVATIONS AT SESEBI (SUDLA), 1937-8.

plete, and that in many places the reliefs still retain the original colours. The figures have not been defaced and only time has caused them damage.

The main entrance to the Temple is on the 'west' (north), the side farthest from the river. The gate is cut through the massive brick wall, some 100 m. square, which surrounds the Temple and other buildings. In late times squatters blocked the 'west' end of the gate with a rough brick wall. At the 'west' end stone blocks on each side of the gate bear the cartouches of Ramesses VI and the figure of the viceroy of Nubia, *Rc-mss-ntw* (*Rc-mss-nht?*). At the 'east' (south) end of the 'north' (east) wall of the gate an inscription dated to the sixth year of Merneptah records the return of a victorious army in his fifth year: this is apparently a reference to Merneptah's victory over the Libyans, and the text itself appears to be a duplicate of a stela in the Temple of 'Amādah. On the 'west' (north) the gate is flanked by two niches, in each of which is a stela, each unfortunately broken (Pl. x, 4). The 'northern' stela contains a duplicate text of the last few lines of the well-known stela at Abu Simbel containing the dialogue of Ptaḥ and Ramesses II,¹ and below it is a line of Syrian and Nubian captives. The 'southern' stela, of which more is preserved, still has 31 lines, and contains a duplicate of the Marriage Stela of Ramesses II at Abu Simbel:² when complete it must have contained at least 70 lines, for the existing text begins only at line 23 of the Abu Simbel text.

Of the interior of the Temple little can be said at present, but the general plan is reasonably certain: the gate leads to an open court with colonnade in which we noted the cartouches of Ramesses IX. Beyond the court lies the Hypostyle Hall, many of whose enormous roofing-blocks still cover the area. Beyond this again we found the Sanctuary with a relief, in colour, of the king before the sacred barque. From the Sanctuary came an interesting sandstone stela (Pl. xi, 3) in which a mother, son, and daughter are concerned: the text is an agreement whereby the mother and son renounce all claims to the father's property (the father apparently being dead) in favour of the daughter, on condition that the latter supports her mother in her old age: on the sides of the stela is a curse against whosoever shall dispute the terms of the agreement. There seem to be excellent prospects of good discoveries in the Temple, for the position of the fallen roofing-blocks makes it certain that robbing could not have taken place in modern times. To the 'north' (east) of the Temple, and connected with it by a small vestibule, is a small chapel (Pl. xi, 1) which is also the work of Ramesses II, and to the 'east' (south) of the chapel is a series of small magazines.

The Temple is situated in the 'north-west' (north-east) corner of a large enclosure some 100 metres square. As far as can be seen at present the buildings within the enclosure are houses and not magazines, but near the centre were noted two columns from a building of uncertain nature. The enclosure wall is some 5 m. thick, with numerous and very big buttresses. In addition to the entrance to the Temple, two gates were noted: a small one, with the cartouches of Ramesses II, lies just 'south' (west) of the entrance to the Temple, and here we found a bronze nail with its head in the form of a -bird: this must have formed part of an inlay. In the 'south' (west) wall is another gate, which is also inscribed with the name of Ramesses II. From the relationship of the roofing-blocks to the side walls, it seems exceedingly probable that the roof of the gate is still in its original position: this fact will give some idea of the extent to which the site is buried. No gates were found in the 'north' and 'east' walls of the enclosure.

Beyond the great enclosure wall are numerous traces of houses, and nowhere could we find ground-level at a depth of less than 2 metres. The houses, in fact, are so deeply buried that we were unable to decide whether there was an outer wall to the town, and on the 'east'

¹ Naville, *TSBA* 7, 119 ff. Our text is preserved from the middle of l. 29 of the Abu Simbel text.

² For the most recent study of the Abu Simbel stela see Kuentz, *Ann. Serv.* 25, 181 ff.

(south) slope of the town mound we descended 4 m. without finding the ground level. The houses and their contents are therefore well protected.

Our last task before covering in our pits and trenches was to try to see whether there were any signs of an occupation of the site before the reign of Ramesses II, for three test-pits had made us suspect this possibility. Accordingly, a room in the 'south-west' corner of the enclosure was completely cleared and at the bottom, a few cm. below the lowest course of bricks, we found a thick brick wall built at an angle across the room (Pl. xi, 2). Below the floor level we found a small sherd of the painted ware so typical of the 'Amarnah Period and the late Eighteenth Dynasty. It may be taken as certain, therefore, that there were two main periods in the history of the town (in addition to post-Ramesside squatters), and that the later of these was in the reigns of Ramesses II and his successors.

The nature of the site, deeply buried as it is, and our preliminary, purely surface work, prevented us from finding many objects. It is clear, however, that the Society has acquired a site which holds out every prospect of being instructive and profitable: the Temple area will certainly yield inscriptional material, and may well provide statuary; everywhere the great depth of accumulation and the obviously unrobbed appearance of the town thoroughly justify an optimistic outlook. 'Amārah West presents a great opportunity, and it is much to be hoped that sufficient funds will be forthcoming to enable the Society to excavate in its entirety what may well prove to be one of the most profitable and important sites that have come within its sphere of work in recent years.

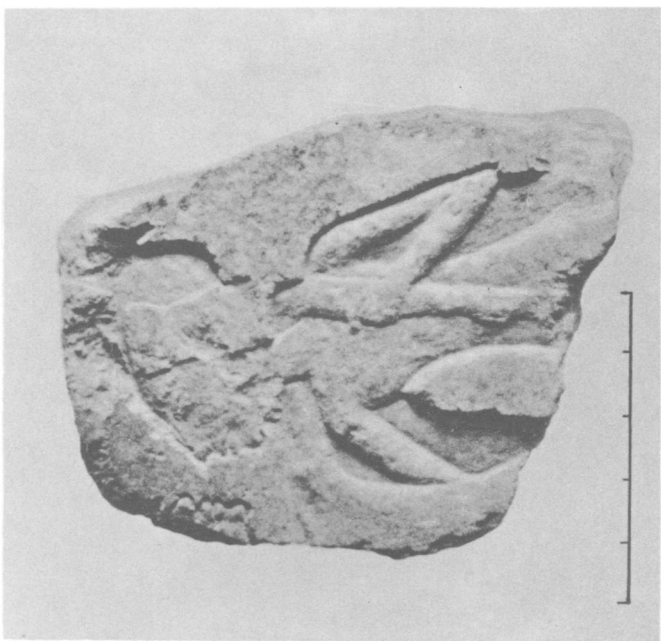

1. Sesebi (Sudla) : Relief of an 'Amarnah princess.

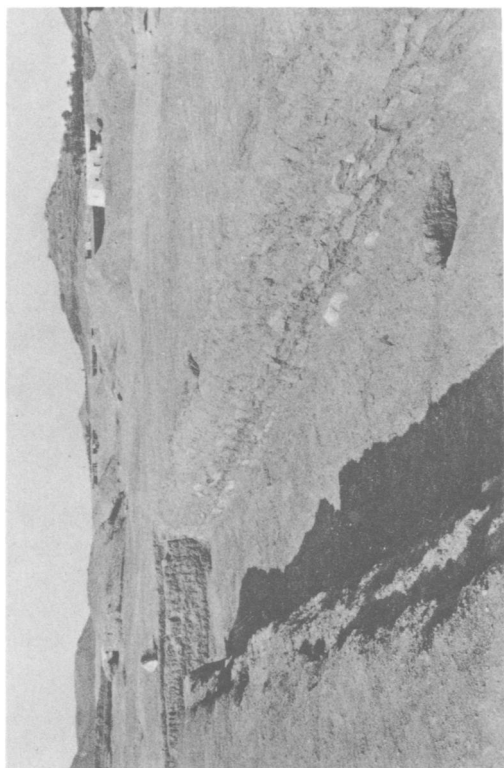

2. Sesebi (Sudla) : Stone lining of the Trench.

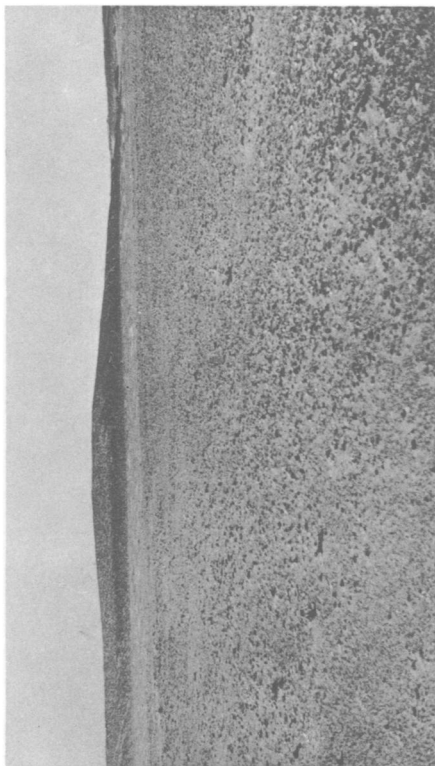

3. 'Amārah West : General view of the site from the 'north'.

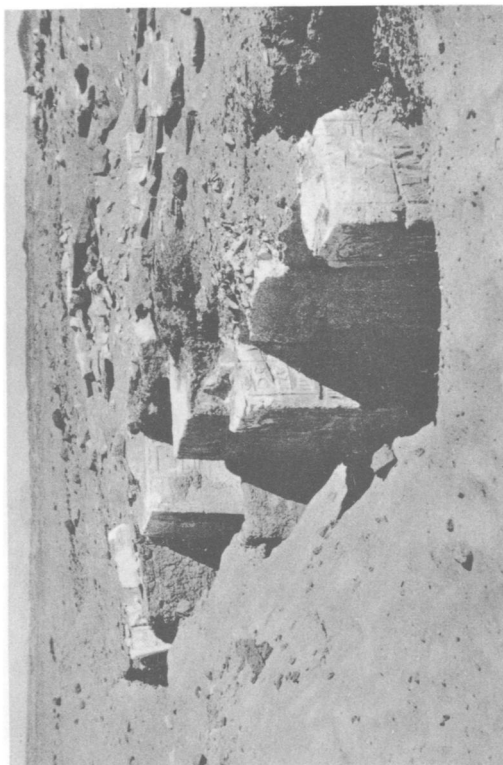

4. 'Amārah West : Temple : main gate and niches.



1. Entrance to "northern" side-chapel.

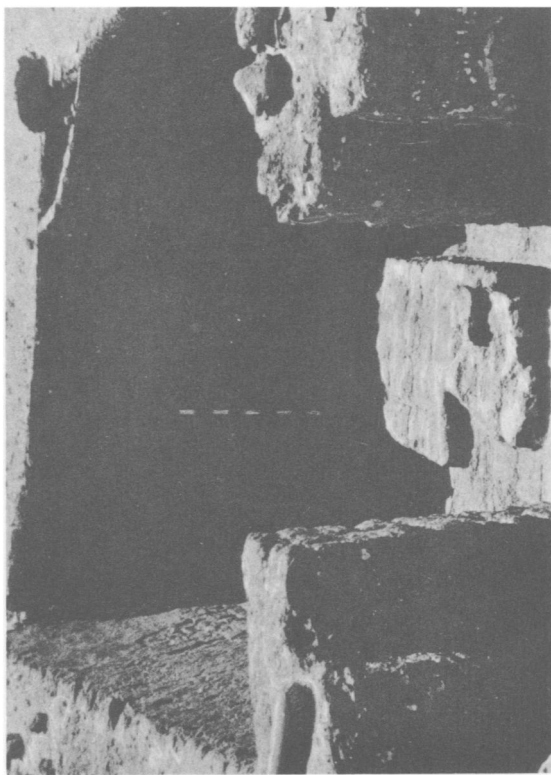

2. Foundation course of first occupation.

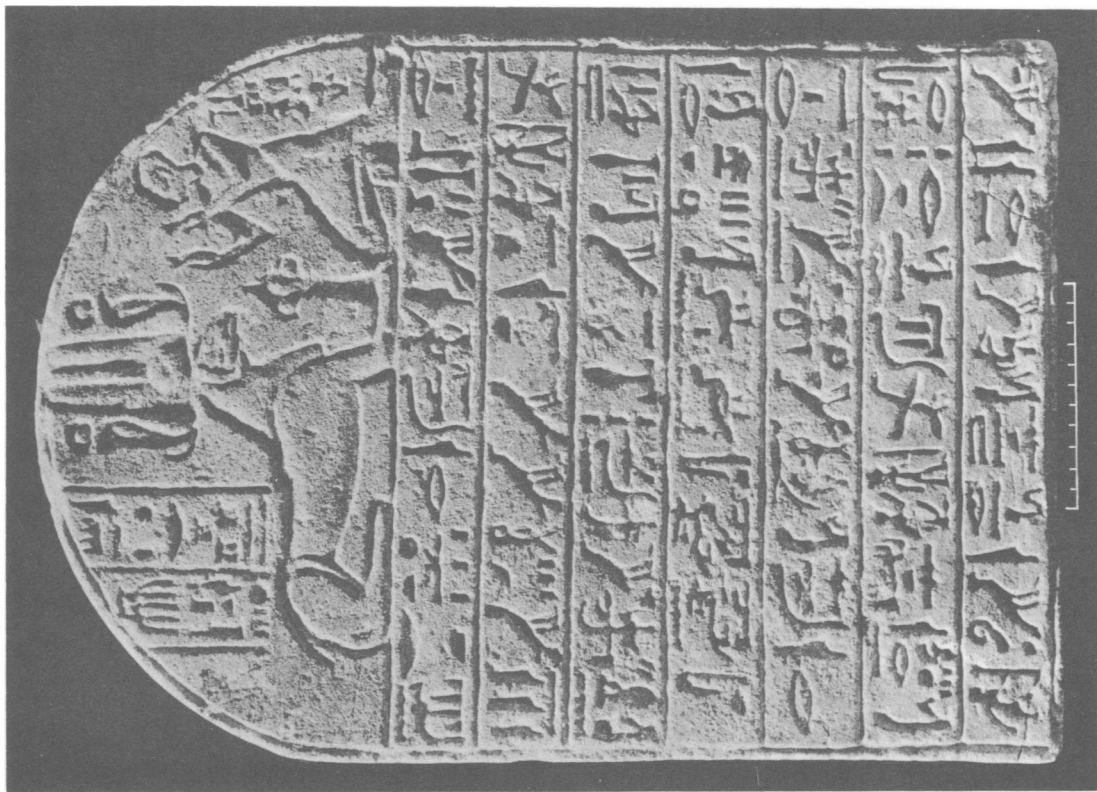

3. Sandstone stela (scale in cm.).

THE HOUSE OF LIFE

BY ALAN H. GARDINER

IN preparing my edition of the papyrus generally known as the Golénischeff Glossary I have had occasion to look into the evidence for the $\square \text{𓆎} \square$ 'House of Life'. That institution is vaguely familiar to Egyptologists as the place where scribes were employed or trained, but the general works barely mention it,¹ and singularly little attention appears to have been paid to the subject. My own investigations have brought to light nothing startlingly new, but it will be useful to possess a collection of the evidence upon which conclusions must necessarily be based. There are doubtless some examples that I have overlooked, but whatever deficiencies might have been found have been lessened by the help of several friends.²

The Berlin dictionary (I, 515) contents itself with the ambiguous definition *Haus der Schriftgelehrten* and omits the most important reference of all, that to the well-known naophorous statue of the $\text{𓆎} \text{𓆏} \text{𓆑} \text{𓆒} \text{𓆓} \text{𓆔}$ 'chief physician Udjeharresnet' in the Vatican, recently re-edited with an admirable commentary by G. Posener in *La première domination perse en Égypte*, pp. 1 ff. The passage relating to the $\square \text{𓆎} \square$ (*op. cit.*, 21) needs so much more discussion than most of our other material that I begin with it, in spite of its late date. After that I shall revert to a chronological order.

(1) Only the essential phrases will be given in hieroglyphic here, since the text can be studied in Posener's book, or in Schäfer's article (see below). The translation runs: 'His Majesty King Darius commanded me to return to Egypt $\text{𓆎} \text{𓆏} \text{𓆑} \text{𓆒} \text{𓆓} \text{𓆔}$ $\square \text{𓆎} \square$ in order to restore the department(s) of the House(s) of Life after (they had fallen into) decay. The foreigners carried me from land to land and delivered me back into Egypt according as the Lord of the Two Lands had commanded. I did as His Majesty had commanded me; $\text{𓆎} \text{𓆏} \text{𓆑} \text{𓆒} \text{𓆓} \text{𓆔}$ I furnished them with all their staffs³ consisting of persons of rank, not a poor man's son among them. $\text{𓆎} \text{𓆏} \text{𓆑} \text{𓆒} \text{𓆓} \text{𓆔}$ I placed them in the charge of every learned man⁴ [in order to teach them?] all their crafts. His Majesty commanded them to be given all (manner of) good things in order that they might exercise all their craft(s). $\text{𓆎} \text{𓆏} \text{𓆑} \text{𓆒} \text{𓆓} \text{𓆔}$ I equipped them with all their ability⁵ and all their apparatus which was on record in

¹ An exception is Kees, *Kulturgeschichte d. alten Orients*, see the Index s.v. *Tempelschule* ('Lebenshaus'), but he quotes only two authentic instances, and many of his assertions are based on the supposed identity of $\text{𓆎} \text{𓆏} \text{𓆑} \text{𓆒} \text{𓆓} \text{𓆔}$ *hwt-nb* with $\text{𓆎} \text{𓆏} \text{𓆑} \text{𓆒} \text{𓆓} \text{𓆔}$, a supposition which I have refuted in my article *JEA* 24, 83.

² Posener has not only helped me with collations of several stelae in the Louvre, but has brought to my notice Nos. 3, 12, 17, 36, 47, besides others already known to me. To Fairman I owe Nos. 26, 42, as well as most of the Edfu examples. Pendlebury has supplied information with regard to No. 8, and Davies with regard to No. 9. To the Editor, as usual, I owe much careful criticism, and by pointing out earlier literature he has saved me from claiming the conclusions under No. 24 as my own.

³ On this difficult word see below, pp. 170-1 and 179. The renderings 'Schüler' (Schäfer, so too now Kees, *ZAS* 73, 87) and 'étudiant' (Posener) are without justification.

⁴ There is reason for thinking that in connexion with the compound *rh-h* the adjective *nb* can sometimes separate the elements or else be placed after the whole. See below p. 170, n. 2, for the former possibility.

⁵ Hardly 'Bedürfnisse' with Schäfer or 'choses utiles' with Posener. The masculine form indicates either a plural meaning 'efficient men' or else an abstract 'efficiency', 'ability'. Cf. *hwt* of the 'Zauber Macht'

which, if my restoration be accepted, it actually receives. Some such definition is all the more likely since Udjeharresnet, not being a first prophet of Neith or of some other god, but only a 'chief physician', courtier, and high official, can hardly be supposed to have possessed the qualifications to reform the 'Houses of Life' as a whole. Still, the latter portion of the passage quoted suggests doubts. The words $\text{𓂏} \text{𓂏} \text{𓂏} \text{𓂏} \text{𓂏} \text{𓂏}$ 'revive all that are sick' point unmistakably to the art of medicine, and it is Schäfer's merit first to have translated *hry hryt* correctly. But how can the commemoration of the names of the gods and so forth be linked up with a mere medical department?

It thus looks as if Udjeharresnet did, after all, reform the Houses of Life in their entirety, although his first sentence refers only to the medical departments. In support of this my ultimate, if very tentative, conclusion I would point to the remarkable iteration of the word 𓂏 'all'; would the writer have spoken of 'all their staffs', 'all their crafts', 'all their talent', 'all their apparatus', 'all the gods', unless he had meant a wholesale restoration of the institutions called by the name 'House of Life'? Supplementing what the writer says by the knowledge that the Houses of Life were centres of the scribes' profession, we thus find in the final sentence a fairly comprehensive statement of the activities there pursued. It is in the $\text{𓂏} \text{𓂏} \text{𓂏}$ that medical and religious books were written and there it was that all questions relating to such learned matters were settled.

One of the main results of the present article will be to show that the conception of the $\text{𓂏} \text{𓂏} \text{𓂏}$ as a training college, and still more the conception of it (to which some have climbed from the humble level of Schäfer's *Ärztesschule*) as a University, is a grave mistake. The purpose of the $\text{𓂏} \text{𓂏} \text{𓂏}$ was, as Udjeharresnet says, for its members to 'exercise all their crafts'. Amid the mass of evidence I shall produce there are singularly few references to teaching. Naturally in a restoration of ruined Houses of Life training of competent staffs would be a necessity. It is not, however, necessary to read into the words of the Vatican statue more than that the new recruits were to be youths of good birth 'under the charge'—note the expression 𓂏 —of men of solid learning. There was nothing in Pharaonic times, so far as can be seen, corresponding even to the Gymnasia where Greek-speaking Egyptians were educated.¹ The local schools ($\text{𓂏} \text{𓂏} \text{𓂏} \text{𓂏} \text{𓂏}$) were doubtless quite elementary. Even the 'school' at the Capital where the 'children of the magistrates' were educated (*Sall.* I, 4, 1) need not have been on a much higher level.² The sparse information that is gained with regard to more advanced teaching suggests that it took place in whatever office or profession had been chosen for a lad's career. The system was that of 'apprentice' ($\text{𓂏} \text{𓂏} \text{𓂏} \text{𓂏} \text{𓂏}$) and 'master' ($\text{𓂏} \text{𓂏}$).³ This agrees with the statement of Diodorus (I, 81): 'The children of the people receive their education from their fathers or relatives, who teach them the professions they are to exercise during their lives'; also at the beginning of the same section, 'the priests instruct their sons in two kinds of letters, those called sacred and those of a commoner kind'. It was apparently only in very late times that priestly education took on a more formal character; a papyrus from Tebtunis dating from the second century A.D. (Grenfell-Hunt, II, 291) mentions that a candidate for priesthood had to pass an examination in religious subjects.⁴

¹ On these see Wilcken, *Gründzüge*, I, 1, 138.

² It was hence that the notion of an Egyptian University first gained currency, cf. Lauth's article *Die altäg. Hochschule von Chennu*, in *Sitzungsb. München*, 1872.

³ This seems substantially the view taken by Erman-Ranke, *Ägypten*, 376. See too my *Late-Egn. Miscellanies*, 34, 7, together with the note. Posener quotes too the epithet 'teacher of the apprentices in the hall ($\text{𓂏} \text{𓂏} \text{𓂏}$) of writings' in a variant of *Anast.* I, 1, 2-3, the sole passage known to me which suggests larger classes.

⁴ See Wilcken, *op. cit.*, I, 2, No. 137.

(2) We now take a leap backwards for a couple of millenia. Since, as I have shown in an earlier article (*JEA* 24, 83), there is no good reason for equating the 'Mansion of Life' with the 'House of Life', and since also a Sixth Dynasty passage (Petrie, *Athribis*, Pl. 6; *Urk.*, I, 267, 11) stating that a nomarch embalmed his father with 'linen of the *pr-nh*' (*sic*) obviously requires emendation of into 'treasury' (see *Urk.*, I, 138, 7; 146, 13), we are left with only one authentic instance of from those early times. This is in an identical passage from two royal decrees releasing the priesthood of Min of Coptos from various *corvées*, among them from (supplying) 'the apparatus of the House of Life', *Urk.*, I, 286, 10; 289, 8, both from the reign of Pharaohs II. The expression is the same as that employed on the Vatican statue (see above, p. 157) and we may suppose the apparatus in question to have included papyrus, reed-pens, ink, medical instruments, perhaps even the whole pharmacopoeia.

(3) The Middle Kingdom is likewise sparing in its references to the House of Life. The earliest is the epithet 'Khnum, lord of the House of Life' above the head of a ram-headed god on a sculptured block of the reign of Sankhkharê recently discovered in the temple of Et-Ṭūd, F. B(isson de la) R(oque), *Tôd* (1934 à 1936), 93. Since other examples of this epithet are applied to Khnum in Ptolemaic times, consideration of the fact is deferred until later; see below under No. 53. M. Posener, to whose kindness I owe this reference, suggests that the epithet of Khnum found already in the Fifth Dynasty (Borchardt, *Grabdenkmal des Sahurê*, Pl. 18; see Sethe's remarks in the Text, p. 94) ought to be corrected into *hnti pr-nh*. This seems to me too daring a conjecture, especially as a *pr-z* is found elsewhere.

(4) The much-betitled prince Mentjuhotpe of the great Abydene stela at Cairo, *CCG* 20539 (Lange-Schäfer, *Grab- und Denksteine*, II, 153), receives the epithet 'Master of the secrets of the House of Life'. The date is the reign of Sesostri I.

(5) At El-Bershah (Newberry, *El Bersheh*, II, 21, 3) an 'overseer of the royal *harim*', Ḥa by name, after some epithets affirming his loyalty to the king, proceeds to speak of himself as 'one who sees to the propitiation of the gods, overseer of writings in the House of Life, to whom all private matters (*dsrw*) are revealed'.

(6) On the Cairo stela 20023 (Lange-Schäfer, *op. cit.*, I, 26), a 'physician' named Ameny has standing in front of him a 'scribe of the House of Life' named Keku. This is the earliest example of the latter title.



(7) Among the subordinate personages on a Middle Kingdom stela is a ; the reading of the first sign is obscure. Leyden V. 67, see *Beschr. Leiden*, II, Pl. 36, No. 49.







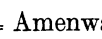
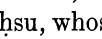
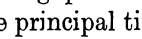
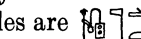

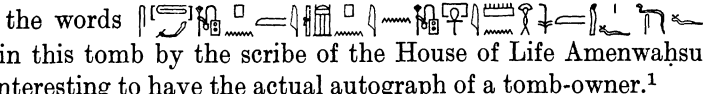
(8) Passing to the Eighteenth Dynasty, the sole piece of evidence dating from that period¹ is the remains of an actual 'House of Life', known to be such by the fact that its bricks bear the stamp . Pendlebury, who made this important discovery at El-Amarna (*JEA* 20, 134), has kindly provided me with the following information. The 'House of Life' consists of two buildings, Q. 42. 19 and Q. 42. 20, which lie 400 metres to the south of the great temple and 100 metres east of the small temple and royal estate that are themselves to the east of the Palace. The 'House of Life' abuts upon the so-called Records Office— 'The place of the correspondence of Pharaoh',² as the bricks

¹ Lieblein, *Dict.*, 598 mentions a where one might be tempted to emend . Lacau, *Stèles du n. empire* (*CCG*), 34117 shows what the true reading is.



² *JEA* 21, 139; an incomplete example Petrie, *Tell el Amarna*, 42. The name is the same as that of the Bureau for the King's Correspondence at Pi-Ramesses as depicted in the reign of Meneptah in the tomb of Tjaty at Thebes (*ZAS* 44, 60), except that there the word *sct* is more suitably preceded by the plural article . Scribes of this institution are occasionally mentioned, e.g. besides Tjaty himself, *Brit. Mus.*, 149; Lefebvre, *Inscr. des grands prêtres*, p. 67, No. 15, c; in another form, *Pap. jud. Turin*, 6, 3.



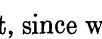
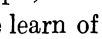

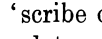
are stamped—as befits the similarity of their activities. Building 19 was entered from the west by a small room, whence there is access to a central chamber with a long room to the south, two rooms to the east and one to the north. A passage runs right round the building, which is much ruined, no floors having survived. The other building (numbered 20) is very small and has a large oblong pier in the middle and a court to the south. The only object of any importance found was a fragmentary funerary papyrus (from 20) now in the Ashmolean Museum.

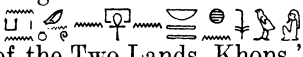
(9) Nineteenth Dynasty. Tomb 111 at Thebes, dating probably from the reign of Ramesses II, belonged to one  Amenwahsu, whose principal titles are  'scribe of the sacred book(s) in the house of Amūn';  'wēb-priest in the house of Amūn';  'conducting the festivals of all the gods at their seasonal feasts';  'conducting the divine bark in peace <through> the virtue of his utterances'; lastly  'scribe who wrote the annals of the gods and goddesses in the House of Life'. Once and once only is Amenwahsu given the title  'scribe of the House of Life'. This is at the end of a long hymn to the two Truths concluding with the words  'This inscription was written in this tomb by the scribe of the House of Life Amenwahsu with his own finger(s).' It is interesting to have the actual autograph of a tomb-owner.¹

(10) In the same tomb the title  is given also to two sons of its owner named respectively  Didia and  Khaemope; it may well have belonged likewise to Amenwahsu's father  Simūt, since we learn of him that he was a  'draughtsman of the Lord of the Two Lands in all monuments belonging to Amūn in Ipet-esut; he who wrote the great name of the Good God in the Ramesseum in the house of Amūn on the west of Thebes.' (10 a). The Khaemope just mentioned evidently moved to Heliopolis, since on a fine stela now in Stuttgart (Spiegelberg-Pörtner, *Aeg. Grabsteine*, I, No. 92 [Pl. 18]), he speaks of his father and mother as being  'of Thebes', while he himself was a  'royal scribe', a  'scribe of the sacred book(s) of the Lord of the Two Lands', also, like his father,  'one who wrote the annals of all the gods in the House of Life', and finally a  'divine father of Rē-Atūm in the House of Life'.²

(11) The owner of the stela Turin 177, published *Rec. Trav.* 4, 142, was a certain  Yuti who bore the title  'scribe of the House of Life of the Lord of the Two Lands'. The exact date has still to be determined.





(12) De Morgan, *Cat. des Monuments*, I, p. 95, No. 150 bis. This graffito on the island of Sehēl gives the cartouche of Ramesses III and beside it the words  'To the spirit of the lieutenant of the House of Life of the Lord of the Two Lands, Khons.' This title is unique and the reading  for that reason somewhat suspect.



(13) Two of the officials condemned for taking part in the conspiracy against Ramesses III had previously borne the title  'scribe of the House of Life', *P. jud. Turin*, 5, 5, in Devéria, *Mémoires et Fragments*, II. That Devéria and his successors have been right in reading  may be seen from *ibid.*, 4, 1, where the sign  in  is quite differently made.

(14) Down to Ramesses III the references to the House of Life have been few and far between. It may not, however, be pure chance that mentions of that institution are more



¹ I owe my copies of this tomb to the kindness of N. de G. Davies.

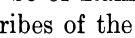

² Curiously enough, however, this same title occurs in the penultimate line of the autograph hymn to the two Truths above quoted, but whether it referred to Amenwahsu or to his son Khaemope is rendered uncertain by the lacunae.





(18) Vienna 51, published *Rec. Trav.* 9, 40, not in Wreszinski, is a Ramesside stela, probably from Abydos, belonging to an Amenmose who was a 'scribe accounting for the grain of all the gods'. His son  Prenen bore the titles  'scribe of the sacred book(s) of the Lord of the Two Lands';  'scribe of the House of Life of the Lord of the Two Lands';  'conducting the festival(s) of Osiris'; finally, he was a  'chief head of the stable of His Majesty, protecting him who is in the Palace'. Evidently a very versatile fellow!



(19) A stela in Bologna (no. 1942 = Kminek-Szedlo, *Catalogo*, pp. 210-11), which we may guess to be of Ramesside date, though the publication speaks of it as Saite, names two  'scribes of the House of Life' named  Amenwah¹ and  Iny respectively.

(20) (21) Two damaged or doubtful examples, Borchardt, *Statuen (CCG)*, III, 162 and *Beschr. Leiden*, XII, 13 = Leyden D 83.

(22) In the heading to the Onomasticon of Amenope (*Hood*, 1, 4; *Gloss. Gol.* 1, 4) the author bears the title  'scribe of the sacred book(s) in the House of Life'; cf. above, No. 17. In the body of the work No. 116 is  'scribe of the House of Life skilled in his duties', emphasizing the special ability of those who held this rank and incidentally a sly bit of self-praise on the part of the author. The item occurs immediately before the enumeration of priests and after the 'royal scribe and lector-priest (who functions) as Horus'.

(23) Next we reach two passages from Ramesside papyri showing that magical spells intended for the use of the living came within the scope of the House of Life. In *P. Leyden 347*, 3, 2 the god  'Horus in *Snwt* (?)', who is known to have had magical powers,² is described as  'master of words, of exalted rank in the House of Life, a creator in the library'. The previous line calls the same deity  'the prince of books', and a third passage (12, 6-7) reveals him as co-operating with Thoth in the authorship of a magical work.



(24) A section of *P. mag. Harris* (= *P. Br. Mus. 10042*) has the heading (6, 10):  'The first spell of all water-enchancements—now the head ones have said with regard to it, Open the heart to no strangers concerning it—a true secret of the House of Life'. The enchancements in question were to ensure the safety of any who travelled by water, and had to be recited over an egg-shaped lump of clay which was then thrown into the Nile. Lange in his edition (p. 55) takes the word  'head ones' to mean 'die leitenden und daher einsichtsvollen Klassen im Volke', but surely this is merely an abbreviation for  'the chief lector-priests', whose magical powers are illustrated in the Westcar Papyrus. I now see that Stricker explains our passage in the same way, in a postscript to his excellent note on the Hebrew expression *הַקְּרָטְמִי-מִצְרַיִם* 'magicians of Egypt', *Acta Or.* 15, pp. 6 and 20 of the offprint. As the facts now ascertained in this matter are not generally known to English readers, I summarize them here. The word **קרטם* had been compared with  *hry-hbt* by Erman (*Rel. d. Äg.*, 308) and *Wb.*, III, 395, but even Erman's apologetic qualification 'in der entstellten Form *chartum*' will hardly allow the etymology







¹ The publication gives  for .



² Learnedly but not very lucidly discussed by Kees, *ZÄS* 64, 107. He places the home (or a home) of this god in the neighbourhood of the White Monastery near Sohäg—the Egyptian name was *Nšw*—and later on adduces evidence to connect his cult with the Oryx Nome, see the tomb of Ameni at Beni Ḥasan. I am not clear whether Kees really regards *Snwt*(?) as the name of a town; the matter seems doubtful in spite of the determinative .

³ The  is written in red.

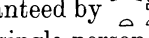
to pass muster. Ranke (*Keilschriftliches Material*, 37) had quoted from an Assyrian text of the eighth or seventh century, among names of priests, doctors, and magicians, a title *hartibi* given to three persons with Egyptian names, but had refused to connect this with the Hebrew word. The possibility thus suggested became, however, a strong probability in the light of the Demotic term *hr-tb* which Griffith (*Stories of the High Priests of Memphis*, n. on *II Kh.* 5, 3) found applied to the sorcerer Ḥor, son of Pa-neshe and tentatively rendered 'librarian'. Spiegelberg (*Demotica*, 1, 4) adduced a good deal more evidence which proved the reading *hr-tb* and indicated the connexion with . To Stricker (*loc. cit.*) belongs the merit of asserting the identity of the Demotic *hr-tb* with the Hebrew term and of citing the Harris passage.

(25) In the Brussels museum is preserved the painted coffin of a scribe 'Ankhefenamūn from the tombs of the priests of Amūn at Dēr el-Baḥri, Speleers, *Recueil des inscr. ég.*, No. 290 (p. 77). Among the scenes is a dais sheltering the symbol , beside which is the legend  'I am Isis the great, the god's mother, lady of the House of Life, dwelling in the Beautiful House', *i.e.* the place of embalmment. The connexion of Isis here with the House of Life seems unique, but is explicable by her great magical powers.

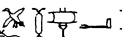
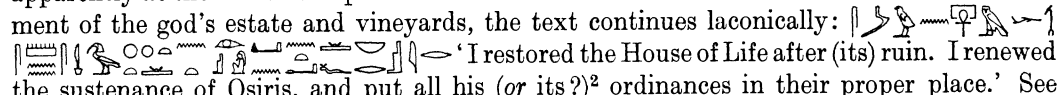
(26) The important reliefs relating to the *sed*-festival discovered by Naville at Bubastis may be almost exact copies of Old Kingdom scenes, though actually dating only from the reign of Osorkon II; but I hesitate to assign the inscriptions that interest us to so early a time. A procession of long-skirted priests, most of whom hold papyrus rolls, is headed , 'friends and masters of magic',¹ *Festival Hall of Osorkon II*, Pl. 8. Among the separate personages are two , 'magician-protectors of the King of Lower Egypt'; there is at least one , 'royal scribe'; finally there is , where the restoration of the sign in lacuna is guaranteed by  *op. cit.*, Pl. 3. Though in each case this legend stands over the head of a single person a plurality was certainly meant and we must render 'the company of the House of Life', with the Old Kingdom word for 'company' (*Wb.*, v, 402) which appears to be nearly synonymous with the later , see below under No. 38. The main interest of these examples is that here the House of Life is explicitly connected with magic, and from a very early date sorcerers belonging to it were evidently in attendance upon the king at the great moment of his Jubilee.

(27) We pass to Saitic times. The chief physician of King Apries  Peftucauneit has left a fine statue of himself, now in the Louvre, where it is known as A 93. The inscriptions record the extensive restorations made by its owner in the temple of Osiris at Abydos, apparently at the behest of Apries's successor Amasis. After the account of the re-establishment of the god's estate and vineyards, the text continues laconically:  'I restored the House of Life after (its) ruin. I renewed the sustenance of Osiris, and put all his (or its?)² ordinances in their proper place.' See *ZÄS* 32, 119 and corrections of Piehl's copy, *ibid.*, 33, 127; the exact sense here of *nt*, which Breasted (*Anc. Rec.*, iv, § 1022) renders 'contracts', is not clear. Nor is it certain whether there is any inner nexus between the mention of the  and the statements before and after.



(28) To the Persian period belongs the Vatican statue that was our starting-point (see No. 1). The other information from the same age is drawn from the famous demotic papyrus known as *Rylands IX*. This contains the long petition of one Peteēse for redress of wrongs done to him and his family by the priests of Teudjoi, the modern El-Ḥibah. The petition is dated in the 9th year of Darius I, but the first reference to the House of Life goes







¹ Probably the same legend is to be restored in Pl. 3 just before the *tst nt Pr-nh* to be mentioned in the text here a few lines further on. For *hryw hk*, see too below under No. 30.

² Cf. *nt n pr-nh* below in No. 50.

back ninety years earlier, when in the 14th year of Psammetichus I Peteēse's great-great-grandfather of the same name brought a tablet of stone from Elephantine to Teudjoi, and in order to record thereon the good deeds he had done in the latter town 'caused the granite-workers, the engravers, the scribes of the House of Life, and the draughtsmen to be fetched'. The demotic text (7, 16) has *n shw pr-ꜥḥ* as in the Ptolemaic decrees; see Griffith, *Ryl. Pap.*, 81, 229. A similar event took place at a later date, *ibid.*, 13, 19, see *op. cit.*, 91, 236.

(29) About fifty-seven years later than the episode narrated above under (28), the second Peteēse, grandson of the first, was nominated by the priests of Teudjoi to accompany Psammetichus II on his expedition to Syria. Many 'prophets' of other towns were going too, and the priests of Teudjoi overcame Peteēse's reluctance with flattering words: 'Behold', they said, 'thou art a scribe of the House of Life; there is not a thing that they shall ask thee to which there is not a suitable answer (?).' So Griffith's translation of 14, 21, see *op. cit.*, 96, 237. The last phrase must surely somehow mean 'for which thou wilt not have an appropriate answer'. Peteēse was sent with the king as being the most learned man that Teudjoi had to offer.

(30) From the Thirtieth Dynasty another fine statue in the Louvre (A 94) mentions the House of Life, but only in a title stressing the magical powers of the personage depicted, namely  Nakhtarhab, a 'chief lector-priest'. The title in question is  'leader of the masters of magic in the House of Life'; for the phrase *hryw hkst* see above under (26). Brugsch, *Thes.*, 687; Pierret, II, 52, top; Piehl, *Inscr. hiérog.*, I, 16. Posener informs me that there is a statue of this same man bearing the same title in the British Museum (No. 1646).

(31) The material for the Graeco-Roman period bulks much larger than that for any earlier age. I begin with three references that belong more to the realm of fiction than of fact, though they are none the less informative on that account. The famous Famine stela on the island of Sehēl (Brugsch, *Sieben Jahre der Hungersnoth*; de Morgan, *Cat. des Monuments*, I, 79-82) has been thought to be a pious fraud on the part of the priesthood of Sehēl, anxious to secure special privileges from the king, who had, it is assumed, favoured the temple of Isis to the detriment of the old gods of the Cataract. Sethe, the last to study the text in its entirety¹ (*Unters.*, II, 75 ff., 103 ff.), thought, on the contrary, that it might be 'die Wieder-auffrischung alter, halb in Vergessenheit geratener Tatsachen' (p. 81). I myself incline to the older view, though perhaps not in quite the positive form in which it has been stated. Anyhow, the inscription purports to be a decree of king Djoser of the Third Dynasty addressed to the then reigning prince of Elephantine.² The cause leading up to the decree was the misery that had befallen Egypt through seven consecutive years of low Niles. In his desire to cope with this catastrophe Djoser appeals to the famous chief lector-priest Imḥōtep (Imouthes) for information about the sources of the Nile and about the god in control of them. The sage seems to have been unable, without previous study, to answer the questions put to him, so he begged permission  'that I may enter into the Mansion of Life and may open the rolls and may seek guidance from them'. Here for once  *pr-ꜥḥ* is replaced by  *hwt-ꜥḥ*, whether by a mistaken archaism or because the  of the Old Kingdom was really identical with the later . The former alternative is preferable, as will be seen in my article on  *JEA* 24, 83.

(32) Whatever view be taken of the historicity of the Famine stela, all are agreed that

¹ Parts are treated by Vandier, *La famine dans l'Égypte ancienne*, 38 ff., 132 ff. Vandier is inclined to share Sethe's views in regard to the historical authenticity of the inscription.

² In a hasty collation of this with the original which I made many years ago I read the name of the prince as  *Mj-hs*; Miūsis.

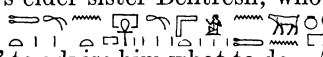
the stela concerning the Princess of Bakhtan was a priestly forgery designed to enhance the prestige of the Theban god Khons. This stela (Prisse, *Monuments*, Pl. 24; full bibliography, Gauthier, *Livre des rois*, III, 41), after recounting the marriage of Ramesses II to Nefrurē, the daughter of the princess of Bakhtan, tells how an envoy from that country came to seek medical aid for Nefrurē's elder sister Bentresh, who had been stricken down with illness. Ramesses summons the  'staff of the House of Life and the courtiers of the Residence' to advise him what to do. A highly skilled physician is sent to Bakhtan, but his help proving of no avail, the god Khons himself, *i.e.* an image of him, is dispatched and by his magical power exorcises the evil spirit.

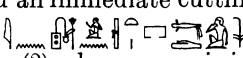
(33) Ancient Egypt has bequeathed to us no more cryptic religious book than *Salt 825*, now *P. Brit. Mus. 10051*, published in *Hierat. Pap. BM*, II, Pl. 31-40. Much of it is devoted to aetiological myths, while other parts are prescriptive magic. It is difficult to say how the references to the House of Life are to be taken. The first allusion (6, 2-3) is to a magical book to be made on the 20th day of the first month of Inundation: 'Thou shalt not divulge it. He who divulges it dies of a sudden death and an immediate cutting-off. Thou shalt keep very far away from it; by it one lives or dies.  It is (to be) read (only) by a scribe of the workshop (?) whose name is in the House of Life.' See on this passage below under No. 57.

The other passage relating to the 'House of Life' describes an ideal structure so called, to be built in Abydos, with gods on all its sides and gods serving as priests within it. The tenses employed appear to be future or prescriptive. One might hesitate with regard to *wnn-f* at the beginning and elsewhere, but *kd* in the clause following seems necessarily an imperative, and later on *nn k*, *nn m:f* can hardly be taken except as futures; lastly *ntf sh:f* in 7, 4 must certainly be the future emphasizing construction discovered by Gunn. Translation is easy, but it is difficult to decide whether the picture painted is pure theological fantasy, or whether it had some practical magical purpose. We can barely dispense with quotation of the whole (6,5-7,7).

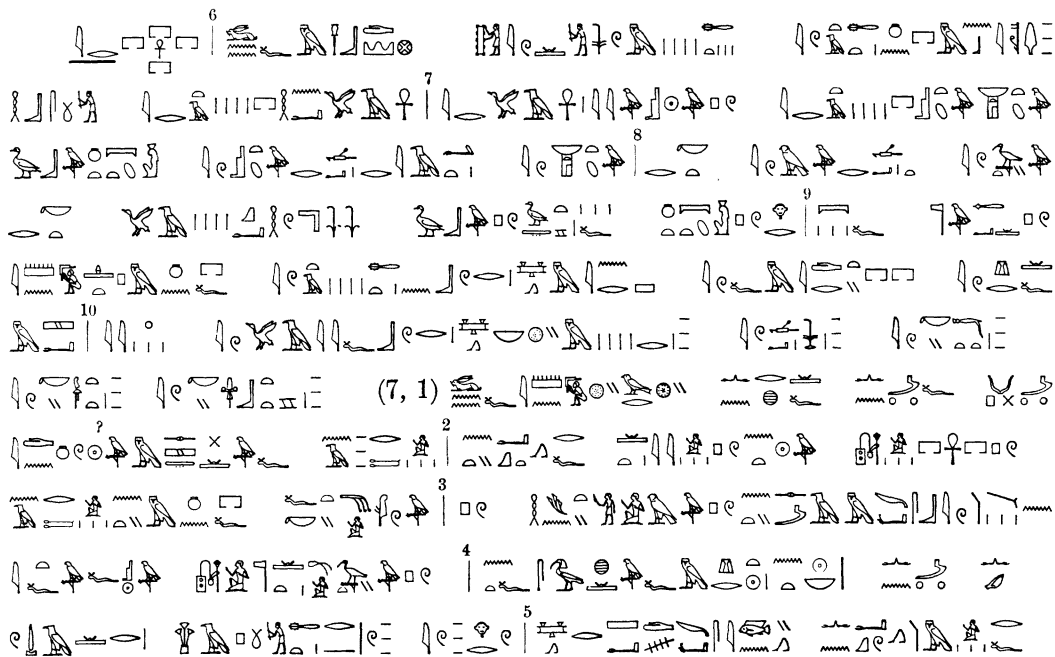

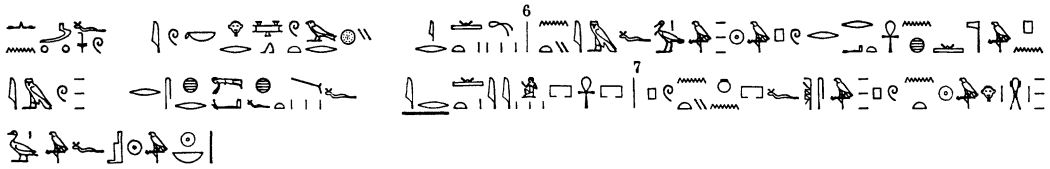

'As FOR the House of Life, it shall be in Abydos. Build it in four bodies, the inner body being of covered reeds (?). As for the four □'s and the ♀—as for the *ꜥnby* ("the living one"), he is Osiris, and as for the four □'s (they are) Isis, Nephthys, Horus and Thoth,¹ Isis being on one side and Nephthys on the other; Horus on one (side) and Thoth on the other. These are the four sides. Gēb is its ground (*i.e.* floor) and Nut its heaven (*i.e.* ceiling). The hidden one who rests within it is the Great God. The four outer bodies consist of a stone that contains two wings, and its lower part (*i.e.* its floor?) is sand, and its outside has severally four doors, one south, one north, one west, and one east. It shall be very hidden and very large. It shall not be known, nor shall it be seen; but the sun shall look upon its mystery. The people who enter into it are the staff of Rēꜥ and the scribes of the House of Life. The people who are in it, the *fkty*-priest is Shu, the slaughterer (*hnty*) is Horus who slays the rebels for his father Osiris, and the scribe of the sacred books is Thoth, and it is he who will recite the (ritual) glorifications in the course of every day, unseen, unheard. Hale of mouths, and secret of body and mouths, they are far removed from sudden cutting-off. No Asiatic shall enter into it; he shall not see it. Thou art very far removed. The books that are in it are the emanations (*brw*) of Rēꜥ wherewith to keep alive this god and to overthrow his enemies. As FOR the staff of the House of Life who are in it, they are the followers of Rēꜥ protecting his son Osiris every day.'

A vignette later on in the papyrus (Pl. 36 of the publication) illustrates the above description, and is reproduced on the next page (Fig. 2). The main interest of the passage is that it is the only one which throws any light on the conceptions lying behind the name □♀□. We need not necessarily follow the writer in interpreting the element ♀ as meaning 'living person' ♀|𓂏|𓂏|𓂏|, but the identification of that 'living person' with Osiris and the statement in 7, 5-6 about the purpose of the books which are in the □♀□ do seem to point to a belief that the primary purpose of literary composition was to maintain life, whether that of the gods, of the king, or of mankind generally. The connexion of the □♀□ with magic and medicine points in the same direction, and it must not be forgotten that the inscriptions on temples and tombs had an indubitable vivifying purpose, even if proofs of the fact are rare and ill-defined. When a learned scribe wrote a religious book, it was more than a mere book that he created or served as the instrument for creating. The book was an 'emanation' or 'soul' of Rēꜥ, the creator-god, see *Wb.*, I, 414(1) for references.² How far back this conception goes we do not know for certain, but it seems likely that it was very ancient. The scribes who wrote in the 'House of Life' were 'followers' or 'servants' of Rēꜥ, embodying in their compositions that creative power to maintain life which was his. Books were thus inspired, they were 𓄀𓄁𓄂𓄃, 'sacred (lit. god's) books' and we recall also the term 𓄀𓄁𓄂𓄃 'god's words'. Was it Egypt that first put the notion of the Word of God into the heart of Man?³

The passage in *Salt* 825 contains the phrases 𓄀𓄁𓄂𓄃 □♀□ and 𓄀𓄁𓄂𓄃 𓄀𓄁𓄂𓄃 which are

¹ The MS. substitutes 'Gēb and Nut' for these last two, clearly wrongly, as the continuation shows.

² The writings here, above under (31) and below under (43), make it highly improbable that the first element in this compound is the word *brw* 'might', which is the view of *Wb.* A further reference for the writing with the three *b*-birds will be found *ZAS* 43, 131.

³ See too, from a rather different angle, Moret, *Mystères égyptiens*, the chapter on *Le verbe créateur*.

of constant recurrence in connexion with the 'House of Life'. There is also, as Posener did not fail to point out, the term $\overline{\text{w}}\overline{\text{t}}\overline{\text{y}}\overline{\text{w}}\overline{\text{t}}\overline{\text{y}}$, which was encountered on the Vatican naophorous statue (above 1), and the discussion of which must still be deferred awhile. What connexion the $\overline{\text{f}}\overline{\text{k}}\overline{\text{t}}\overline{\text{y}}$ -priest¹ and the obscure $\overline{\text{h}}\overline{\text{n}}\overline{\text{t}}\overline{\text{y}}$ ² or 'slaughterer' had with the 'House of Life' is not clear.

(34) Bergmann, *Buch vom Durchwandeln der Ewigkeit*. In a passage describing the experiences awaiting the blessed dead, it is said of the owner of the papyrus (60-1): $\overline{\text{w}}\overline{\text{t}}\overline{\text{y}}\overline{\text{w}}\overline{\text{t}}\overline{\text{y}}$

$\overline{\text{f}}\overline{\text{k}}\overline{\text{t}}\overline{\text{y}}$ 'thy *hw*-food finds achievement beside the library, thy provisions (emend *dfw*) come into being in the House of Life'. The thought is akin to that of *Salt* 825; here, however, books have the power not only to bestow life, but also to produce food, the means of life.³

(35) Variants of the above passage on a stela from Hawāra (*Rec. Trav.* 36, 76) do not mention food at all. The published text reads $\overline{\text{w}}\overline{\text{t}}\overline{\text{y}}\overline{\text{w}}\overline{\text{t}}\overline{\text{y}}$ ' of the Library, thy glorifications are in the House of Life, and thy name shall be pronounced by the staff of the

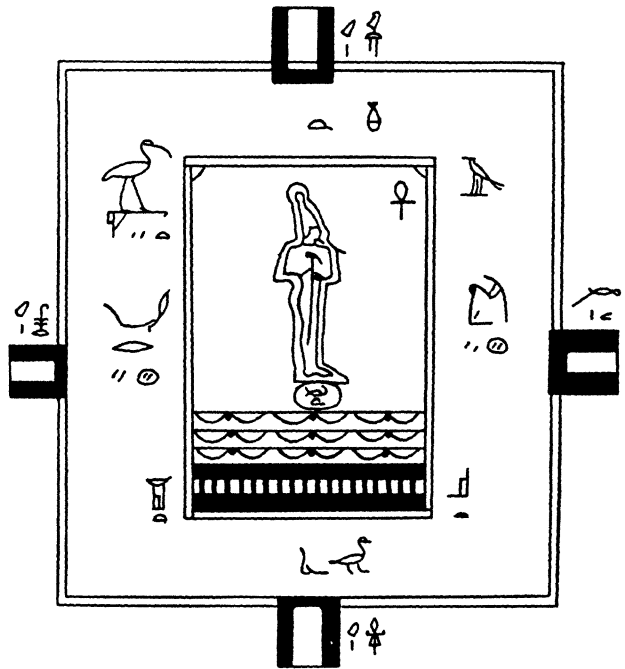

FIG. 2.

House of Life in reading its glorifications.' On the other face of the same stela (*op. cit.*, 78) there is an invocation to a whole series of priests starting thus:—'O ye *wēb*-priests, prophets, lectors, everyone $\overline{\text{w}}\overline{\text{t}}\overline{\text{y}}\overline{\text{w}}\overline{\text{t}}\overline{\text{y}}$ all [scribes] of the House of Life, embalmers (?), *wndw*, *ka*-priests, and all mummifiers of the necropolis . . . who shall see this stela, and read the divine writings. . . .'



(36) Posener points out in a letter that in *Bremner-Rhind*, 29, 16, where Faulkner suggested $\overline{\text{w}}\overline{\text{t}}\overline{\text{y}}\overline{\text{w}}\overline{\text{t}}\overline{\text{y}}$ we ought to read $\overline{\text{w}}\overline{\text{t}}\overline{\text{y}}\overline{\text{w}}\overline{\text{t}}\overline{\text{y}}$. The word occurs in a heading: $\overline{\text{w}}\overline{\text{t}}\overline{\text{y}}\overline{\text{w}}\overline{\text{t}}\overline{\text{y}}$ 'It is a secret book in the House of Life, which no eye shall see, the secret book of overthrowing Apopis.'



(37) The Mendes stela. In the reign of Ptolemy Philadelphus the temple of the ram-god of Mendes was built anew, and a stela commemorating the benefits which that king conferred upon the city is preserved in the Cairo Museum. When, some time after the 21st year, a new sacred ram was discovered in the vicinity, petition was sent to Ptolemy requesting



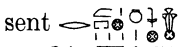



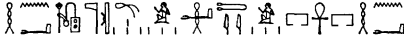







¹ See *Wb.*, I, 580 (4) and Gauthier, *Personnel du dieu Min*, 77-9; further Sethe in *ZÄS* 57, 24 commenting on *Bk. Dead*, spell 115, where again the *fkty* is identified with Shu.

² See *Wb.*, III, 122 (14).

³ In *op. cit.*, 54 we find a *pr-tnh-irw*, but this is probably different, cf. also Dümichen, *Resultate*, I, 47, 10.

that the scribes of the House of Life should come and inspect it. 'Thereupon His Majesty sent  to the temples of Upper and Lower Egypt to cause to come [ the [staff of the House of Life] consisting of the *wꜛb*-priests of the nomes and the prophets of the Two Lands consisting of the learned men² in their cities.  And after the staff³ of the House of Life had seen it, they recognized its markings⁴ according to the ritual-book.' Then a titulary was made for this new re-embodiment of no less than four gods as had been done since ancestral times. *Urk.*, II, 48, 11-49, 12.

(38) The priestly decrees of the Ptolemaic age, usually written in hieroglyphic, demotic, and Greek, have a stereotyped opening that enables them to be treated together. Attention will be paid to the differences between the versions only in the vital portions. After the date and royal titulary the texts continue: 'On this day a decree (, *ψήφισμα*): the temple-overseers and prophets, the priests who enter into the holy place to adorn the gods with their raiment  with the scribes of the sacred book(s) and the staffs of the House of Life and the other *wꜛb*-priests who had come from the two halves of Upper and Lower Egypt (for such and such a purpose, being assembled in such and such a place)—they said': (then follows the substance of the decree). The hieroglyphic quotation above given is actually from the En-Nibērah version of the Rosettana (*Urk.*, II, 172); for similar texts see Canopus (*op. cit.*, 126), Philensis I (*op. cit.*, 201), Philensis II (*op. cit.*, 216); Gauthier-Sottas, *Un décret trilingue*. Instead of , Canopus has ; the demotic rendering of this is always *nr shw pr-ꜥnh*⁵ and the Greek *ἱερογραμματεῖς*. It is noticeable that the scribes of the House of Life are definitely ranked as priests.



The moment has come at which we can no longer postpone discussion of  and the related words. The variants  (Princess of Bakhtan stela, No. 32 above),  (Canopus, Tanis version, below, No. 39, and so too No. 35 above),  (Bucheum, No. 42 below) and  (Mendes stela, above, No. 37) all show  as initial letter, and *Wb.*, v, 338 takes the word as a collective *tt* 'Schreiberschaft', though quoting an example  from Naville, *Mythe d'Horus*, 24, where a single scribe is designated. It would accord with this latter use that  is found over the head of the scribe who follows the king on the palette of Narmer, and in a very puzzling ritualistic (?) papyrus from Quibell's find at the Ramesseum (late Middle Kingdom) a single official appears to bear the title . It is difficult to see how a feminine collective could be used of a single male person, though this was apparently the view of Sethe in quoting the example from the palette of Narmer (*Der Ursprung des Alphabets in Nachr. Göttingen*, 1916, Heft 2, p. 157). The writing  looks like a masculine plural and perhaps the simplest solution is to admit the existence both of the collective  and of a form in *-y* derived from it;  would thus be an analogon to , *knbtjw*. This solution is favoured by the writing  in *Salt 825*,

¹ So restored by Sethe.

² *Rh-ht*; for the writing here *cf.* below, No. 46 and Budge, *Egyptian Antiquities in the Possession of Lady Meux*, Pl. 11, l. 12 .

³ For discussion on this word, see under (38).

⁴ Since *ybut*, usually rendered 'form' (*Wb.*, I, 8 (1) 'Gestalt'), is clearly connected with *ybw* 'to brand' I do hesitate to render it 'markings' here.

⁵ A broken passage with  in Griffith, *Two Hieroglyphic Papyri*, Pl. 14, may have contained the same expression in hieroglyphs, if any importance is to be attached to the writing ; otherwise  could be read.



7, 2.6 corresponding to $\overline{\text{𓄏}} \overline{\text{𓄏}} \overline{\text{𓄏}}$ of the Vatican naophorous statue (above, No. 1), where the close connexion with $\overline{\text{𓄏}} \overline{\text{𓄏}} \overline{\text{𓄏}}$ renders inevitable the identification with $\overline{\text{𓄏}} \overline{\text{𓄏}} \overline{\text{𓄏}}$, $\overline{\text{𓄏}} \overline{\text{𓄏}} \overline{\text{𓄏}}$. The explanation that involuntarily suggests itself is that $\overline{\text{𓄏}}$ in all the Graeco-Roman examples is a false transcription of hieratic $\overline{\text{𓄏}}$, which is indeed extremely similar, and corroboration of that view seems to be offered by the appearance in several places of $\overline{\text{𓄏}} \overline{\text{𓄏}}$ and the like for $\overline{\text{𓄏}} \overline{\text{𓄏}}$, which we habitually read *mdst*; *Wb.*, *ibid.* quotes $\overline{\text{𓄏}} \overline{\text{𓄏}}$ as a very late variant for $\overline{\text{𓄏}} \overline{\text{𓄏}}$ as epithet of the goddess Seshat, and below in No. 46 (Cairo 22017) we shall find the title $\overline{\text{𓄏}} \overline{\text{𓄏}}$ written $\overline{\text{𓄏}} \overline{\text{𓄏}} \overline{\text{𓄏}}$. We might accordingly conjecture that $\overline{\text{𓄏}} \overline{\text{𓄏}} \overline{\text{𓄏}}$ and its equivalent $\overline{\text{𓄏}} \overline{\text{𓄏}} \overline{\text{𓄏}}$, both read *mdstyw* and mean literally 'the bookmen'. To this, however, there are two serious objections, the lesser being that in that case we should have to abandon the comparison with $\overline{\text{𓄏}}$ on the palette of Narmer and with the Middle Kingdom $\overline{\text{𓄏}} \overline{\text{𓄏}}$ quoted above. The greater objection is that $\overline{\text{𓄏}} \overline{\text{𓄏}} \overline{\text{𓄏}}$ and variants possess, as *Wb.*, *ibid.* points out, a wider sense that has nothing to do with books whatsoever, namely as meaning (1) 'people' (or the like) of a god (who sustains them), and (2) 'partisans' of an enemy. The Graeco-Roman examples used by *Wb.* are unknown to me, but on a late stela in Leyden (*Beschr. Leiden*, VII, Pl. 16, No. 20 = Piehl, *Inscr. hiérog.*, III, 30, 6) the owner, addressing Onūris-Shu, says $\overline{\text{𓄏}} \overline{\text{𓄏}} \overline{\text{𓄏}}$ (*sic*) $\overline{\text{𓄏}} \overline{\text{𓄏}} \overline{\text{𓄏}}$ 'I commanded thy people' and in *Salt* 825, 7, 2 (above, No. 33) it seems more natural to translate $\overline{\text{𓄏}} \overline{\text{𓄏}} \overline{\text{𓄏}}$ $\overline{\text{𓄏}} \overline{\text{𓄏}}$ as 'the staff of Rēc' than as 'the bookmen of Rēc', though from the context it emerges that the staff of Rēc is here equated with the scribes of the House of Life. More decisive are two passages from the Tomb Robberies Papyri where Peet was at a loss to know whether to read $\overline{\text{𓄏}}$ or $\overline{\text{𓄏}}$ but where he finally (p. 186) favoured the latter; in his autographed text of *P. Brit. Mus. 10052*, 2, 1, we read $\overline{\text{𓄏}} \overline{\text{𓄏}} \overline{\text{𓄏}}$ $\overline{\text{𓄏}} \overline{\text{𓄏}} \overline{\text{𓄏}}$ $\overline{\text{𓄏}} \overline{\text{𓄏}} \overline{\text{𓄏}}$ $\overline{\text{𓄏}} \overline{\text{𓄏}} \overline{\text{𓄏}}$ 'they were in his gang of thieves'; rather similarly 7, 3. Gunn points out to me that in *Ptahhotpe*, 120 'If thou art one who sits $\overline{\text{𓄏}} \overline{\text{𓄏}} \overline{\text{𓄏}}$ at the table of a man greater than thyself' the much later version of *P. Brit. Mus. 10509* writes $\overline{\text{𓄏}} \overline{\text{𓄏}} \overline{\text{𓄏}}$ $\overline{\text{𓄏}} \overline{\text{𓄏}} \overline{\text{𓄏}}$. Since the phrase $\overline{\text{𓄏}} \overline{\text{𓄏}}$ 'dinner-table of the Prince' shows, according to *Wb.*, v, 338, the variant $\overline{\text{𓄏}} \overline{\text{𓄏}}$ (Cairo 20709, *b* is the source), and since there is a word $\overline{\text{𓄏}} \overline{\text{𓄏}}$ for the woodwork of a ship (*Wb.*, v, 339 (13); see *Wenamūn* 2, 4. 49. 56) perhaps, utilizing all the *data*, we may provisionally combine them in some such manner as this:—There is a word $\overline{\text{𓄏}} \overline{\text{𓄏}}$ *tt* meaning a wooden board in a very general sense; hence is derived $\overline{\text{𓄏}} \overline{\text{𓄏}}$ *tt* for the 'board' or 'table' at which one sat to eat, or where at least the provisions for eating were stacked; hence $\overline{\text{𓄏}} \overline{\text{𓄏}}$ *tt* for *commensales*,¹ to use the medieval Latin expression, and then more generally, 'staff', 'gang'. The writing with $\overline{\text{𓄏}}$ was perhaps due to the confusion in hieratic of $\overline{\text{𓄏}}$ with the rare sign for $\overline{\text{𓄏}}$ (see Dévaud's note on *Ptahhotpe*, 120) rather than with that for $\overline{\text{𓄏}}$, but was apt to be retained when the $\overline{\text{𓄏}} \overline{\text{𓄏}} \overline{\text{𓄏}}$ of the $\overline{\text{𓄏}} \overline{\text{𓄏}} \overline{\text{𓄏}}$ were spoken of, since the latter happened to be men concerned with papyrus-rolls. Perhaps the writing of $\overline{\text{𓄏}} \overline{\text{𓄏}}$ for $\overline{\text{𓄏}} \overline{\text{𓄏}}$ *mdst* 'book' is entirely late and secondary. I have tentatively rendered $\overline{\text{𓄏}} \overline{\text{𓄏}} \overline{\text{𓄏}}$, $\overline{\text{𓄏}} \overline{\text{𓄏}} \overline{\text{𓄏}}$ and the like by the English 'staff'. Possibly in some cases, *e.g.* in (1) above, it may be the plural of the collective, *i.e.* staffs, and not as elsewhere, the plural of a derivative in *-y* from that collective, *i.e.* properly 'men of the staff'.

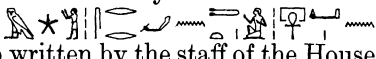
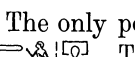

In conclusion, I desire to emphasize the hazardous and doubtful character of the above inferences. Not all the relevant facts are at my disposal, but on the other hand some that I have cited were clearly not known to the compilers of the Berlin Dictionary, which appears

¹ It must, however, be remembered that the Egyptians did not dine 'at the same table' in our sense. For important additional evidence confirming the reading *tt* and the meaning 'staff' see the Postscript to this article.

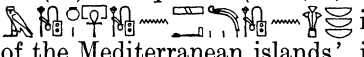

to be in general agreement with my deductions. I have been more or less consciously influenced by the fortunes of the English word 'board'.

(39) *Canopus*, 34 (*Urk.*, II, 151-2) ordains that daily and on feastedays male and female singers shall sing in honour of the dead princess Berenice  'the hymns of worship written by the staff of the House of Life and given to the head-teacher of the singers, and the like shall be written in the books of the House of Life'. The only point of interest in the demotic is that here, as in (35), it writes *shw pr-ꜥnh* for . The Greek has οὗς ἀν ὑμνοὺς οἱ ἱερογραμματεῖς γράψαντες δώσω τῷ ᾠδοδιδασκάλῳ ὧν καὶ τὰ ἀντίγραφα καταχωρισθήσεται εἰς τὰς ἱερὰς βύβλους. It is to be noted here and in the adjacent entries that the Greek consistently ignores the existence of the House of Life, substituting for it everywhere the adjective *ἱερός*. The expression 'books of the House of Life' does not necessarily mean 'kept in the House of Life'; the place of production may be intended.

(40) *Canopus*, 32 (*Urk.*, II, 149). The diadem to be placed on the head of the image of the dead princess is to be designed out of certain symbols which in combination will reveal her name of Berenice  'through (dem. *r-he* according to) its forms in the writing of the House of Life'. The Greek has κατὰ τὰ ἐπίσημα τῆς ἱερᾶς γραμματικῆς 'according to the devices of the sacred script'. Probably the plural strokes in  have no significance, and the analogy of *ibid.*, 37 (below, No. 41) makes it probable that *š* here means 'mode of writing' and not 'writings' or 'books'. The hieroglyphic script is evidently meant. On the entire passage see *ZÄS* 43, 156-7.

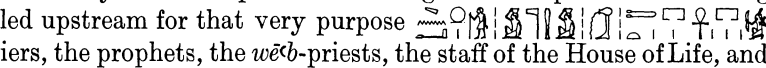
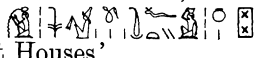
(41) *Canopus*, 37 (*Urk.*, II, 154). The decree is to be 'carved on a tablet of stone or metal  in writing of the House of Life, writing of letters, and writing of the Mediterranean islands', in the Greek *ἱεροῖς γράμμασι καὶ αἰγυπτίοις καὶ ἐλληνικοῖς*. The 'writing of the House of Life' is of course hieroglyphic, as above in (40), and for it Rosettana (*Urk.*, II, 197) and Philensis I (*Urk.*, II, 213) substitute  'the writing of the god's words', the demotic following the hieroglyphic everywhere.

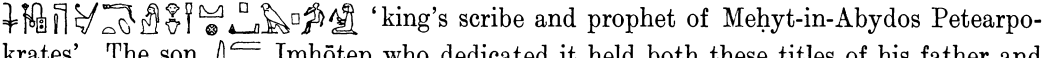
(42) A new Buchis bull, which had been born in the 19th year of Ptolemy VI, was installed at Thebes in the 24th year in the presence of the god Amenope and of the king himself, who had travelled upstream for that very purpose  'with his courtiers, the prophets, the *wēb*-priests, the staff of the House of Life, and all the multitude¹ of the entire (land)', Mond-Myers, *Bucheum*, Pl. 41, No. 9, ll. 10-11, and vol. II, p. 7. In the preliminary inspection of Asphynis no mention is made, as on the Mendes stela, of the scribes of the House of Life, but they may have been included in the persons who are named, *viz.* the  'wēb-priests, the royal inspectors, and the soldiers of the Two Great Houses'.

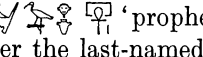
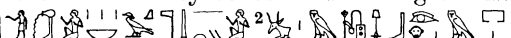
(43) Louvre C 232 (Pierret, *Rec. Inscr. Louvre*, II, 21. 67); the copy of the relevant portion is due to the kindness of M. Posener. The owner of this Ptolemaic stela was the  'king's scribe and prophet of Mehyt-in-Abydos Petearpokrates'. The son  Imhōtep who dedicated it held both these titles of his father and among others that of  'prophet of Thoth-dwelling-in-the-House-of-Life'; it is permissible to ask whether the last-named designation means more than that its recipient was acknowledged to be a man of great learning. In the principal inscription Petearpokrates calls upon a number of his colleagues to praise Thoth when they behold this writing of his. The interesting invocation begins as follows: 





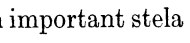

¹ Fairman renders 'soldiers', but is not the late sense 'multitude', **ⲙⲏⲏⲏⲥ** preferable here?

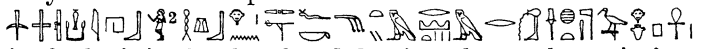

² Probably for .

 etc. 'O all ye priests who penetrate into the words of god and are skilled in writings, ye who are enlightened in the House of Life and have discovered the ways (?) of the gods, who have penetrated into the archives of the Library and can interpret the mysteries (*itnw*) of the Emanations of Rēc (*i.e.* sacred books, see above p. 168), who are skilled in the work of the Ancestors and who open up (?) the heart of what is upon the wall, ye who carve the tomb(s) and who interpret the mysteries—if ye come (lit. who shall come) to Rostaw and if ye all approach the sacred land', etc. We are reminded of Neneferkaptaḥ in the story of Sethon, see below No. 55.

(44) The same son Imḥōtep bears the same title  on an important stela in Vienna, Wreszinski, *Aeg. Inschr.*, I, 25 (p. 89).

(45) Cairo *Cat. Gén.* 22070 has yet another example of the same title. This is on a stela from Akhmīm belonging to the  'The s . . . -priest³ who is in the chamber, *hsk*-priest, dancer, lector in face of Min, *fkty*-priest, overseer of the deserts, overseer of the priests of Sakhmet,⁴ prophet of Thoth-dwelling-in-the-House-of-Life, scribe of the sacred books of Min, Aḥmose.' See Ahmed Bey Kamal, *Stèles ptolémaïques et romaines (CCG)*, p. 65 and Pl. 22.



(46) On another Akhmīm stela in Cairo (*Cat. Gén.*, No. 22017; *op. cit.*, p. 19 and Pl. 7) the owner  Haronnofre bears, among other titles, the following:  'over the secrets of the god's words';  'learned (*rh-ht*, see above p. 170, n. 2) in every (papyrus)-chest of the House of Life belonging to the House of Min';  'chief teacher of the children of the prophets, *wēb*-priests and *ḳ*-priests'; and  'scribe of the sacred book(s)'. In the title mentioning the 'House of Life' this probably serves only to indicate that the boxes in question contained papyri written in hieroglyphic; the genitival particle  is doubtless to be taken with *hnw*, not with *pr-ḥnh*.



¹ Posener hesitates between  and . Perhaps some writing of *shrw*.





² The right reading is *ihb*, not *iḥb* as Ahmed Bey Kamal gave, see Gauthier, *Personnel*, 92, n. 3.





³ In discussing this title Gauthier, *op. cit.*, 49, has overlooked my contention (*Egn. Gr.*, p. 527, under Aa 25) that all we know of its reading is that it began with *ś*.



⁴ The simple 'priest (*wb*) of Sakhmet' occurs Murray, *Saqq. Mast.*, I, Pl. 11 = Mar., *Mast.*, D 62; on the Middle Kingdom Cairo stelae 20391, 20735 (see Lange-Schäfer, *op. cit.*); also on a papyrus fragment of similar date in Moscow, see Turajev, *Egyptologicheskia Zamietki* in *Bull. de l'Inst. imp. des Sciences*, Petrograd, 1916, p. 18; finally in *P. Ebers* 99, 2-3. The 'overseer' of such priests is found, besides here and below in No. 49, also in *Ann. Serv.* 22, 41. 140 (tomb of Petosiris); *Urk.*, II, 2, 8 ('in the entire land'); 4, 2 ('of Upper and Lower Egypt'); Spiegelberg, *Demot. Inschr. (CCG)*, p. 30, hierogl. text, l. 1; and finally in a demotic docket to be mentioned below. The context of the example in the Ebers papyrus shows that this priest was a doctor or magician of sorts. In the scene at Šakḳārah the bearer of the title, who was also a 'śhd ('instructor'?) of doctors', is shown superintending the cutting up of an ox. With this agrees quite remarkably the evidence of a papyrus of the reign of Hadrian described by Sudhoff in his book *Ärztliches aus griech. Papyrus-Urkunden*, p. 9. Here a *ἱερομοσχόσφραμιστής* testifies that he has examined a calf to be sacrificed and has found it pure; the demotic signature names as the writer of the document an 'overseer of the priests of Sakhmet'. Such examination of slaughtered cattle may well have been one of the chief functions of these priests, and as confirming this suggestion we must remember that Sakhmet was the savage lioness-goddess who would naturally be concerned with slaughter. However, it must also be recollected that the expression 'year of pestilence' is equally closely associated with her name, so that every doctor who treated serious epidemics may have claimed the title. In the Ebers passage (= *P. Edwin Smith*, I, 6, see Breasted, p. 106) the 'priest of Sakhmet' is mentioned as feeling the pulsation of the blood in various parts of the human body, so that his work was not exclusively associated with the sacrifice of animals.



(47) On yet another Akhmīm stela (Florence, inv. 7641, *Rec. Trav.* 20, 90) the owner  Pahēt (?) was a  's . . . -priest and scribe of the House of Life'.¹



(48) One  Onnofre whose stela is in the British Museum (No. 808) had the titles  'the *hsk*-priest² who is in the chamber, the king's scribe of the House of Life'. Is this strange-looking title comparable to the earlier  , *cf.* Nos. 11, 18?

(49) The Lee collection at Hartwell House, near Aylesbury, once contained the stela of a woman which is published in Sharpe, *Egn. Inscr.*, II, 68. Her father  Peteēse held a number of priesthoods, that of Osiris at the head of them, and in his capacity as a learned man occupied several offices that have been mentioned once or many times in this article, *e.g.*  'scribe of the sacred book(s)';  'overseer of the *wēb*-priests of Sakhmet'.³ Quite unique, on the contrary, is apparently the title  'great prophet (lit. god's servant) of the House of Life', the deity in question presumably being Thoth.

(50) In a description of a particular feast at Edfu the journey of Horus and his company of gods from point to point is related in detail. At the end of the second day they  'proceed to the hall of the House of Life', where  'all the ceremonial of the House of Life is performed, and  the interpretation of the naming (??) is made at time of evening'. Then they spend the night in this place. (Chassinat, *Temple d'Edfou*, v, 135, ll. 44-5, controlled by Berlin photo. 70; translation, Brugsch, *Drei Fest-Kalender*, p. 15.) The impression given is that the House of Life is not in the temple at all, and the purpose of the visit seems clearly to be to obtain interpretation of some kind from the learned. Another similar visit on the first day of the festival occurs in ll. 12-13, where we read  (they) proceed to the hall of the House of Life, and the business is done by the prophet'. A burnt-offering is then made, and after this various religious compositions are read by the scribe of the sacred book(s).

(51) In the Library of the temple of Edfu (see below, p. 177) there is only one reference to the House of Life. This is in an epithet of Osiris Khentamenthes, the lord of Abydos  'who initiated the House of Life in the work of its lord', Chassinat, *op. cit.*, III, 346. Here, if I have understood the sign  aright, 'his lord' will refer to Thoth, whom Osiris took as his scribe and to whom he showed special favour, see Diodorus, I, 1, 15-16.

(52) The goddess of writing was naturally associated with the House of Life, but references to such an association are rare. At Edfu we find  'Seshat of Lower Egypt, the lady of plans, the lady of writings in the House of Life' (Chassinat, *op. cit.*, II, 31); also Sethe, in Borchardt, *Grabdenkmal des Königs Sahuret*, Text, 78, quotes as another late epithet  'dwelling in the House of Life' on column 6 R of the Hypostyle Hall of the temple of Karnak.

(53) An example of the epithet *hnti pr-nḥ* applied to the ram-headed Khnūm has been quoted (No. 3 above) from as early as the Eleventh Dynasty. Khnūm was the builder *par excellence*, and as all Egyptian monuments are adorned with inscriptions to their full extent it is not unnatural to find him so described. Hence we find him as  'in the House of Life' at Edfu, combining to protect the temple with Neith of Sais, Nut, and Thoth in his name of Heka (Magic), see Chassinat, *op. cit.*, VI, 147 (*cf.* too 143). Similarly at Esna  *Rec. Trav.* 27, 88.

(54) There are mentioned also at Edfu seven builder-gods, of whom  is naturally one. Chassinat, *op. cit.*, IV, 353; VI, 174, 185, 321. In a speech put into the mouths of these

¹ Gauthier (*Personnel*, 100) claims one Imḥōtep, owner of the table of offerings, *Cat. Gén.* 23130 of the Cairo Museum, as a *sš pr-nḥ*. But neither the text nor the Plate in Ahmed Bey Kamal's publication confirms this.

² See *Wb.*, III, 164 (2).

³ See above p. 173, n. 4.

mentioning a teacher of the children of the priests, but all that is there said is that he was 'learned in every (papyrus-)chest of the House of Life belonging to the House of Min', and this probably only means that he was an adept in all the subjects dealt with in the religious books to be found in his local temple-library.

Great stress is laid on the productive aspect of the House of Life, and we can have no doubt that this was the workshop where most sacred books and inscriptions were composed and written. It seems likely that the ever-increasing frequency with which the House of Life is mentioned as the Christian era approaches was due to the growing differentiation between religious and secular matters, and in particular between the hieroglyphic and hieratic scripts on the one hand, and the demotic or epistolographic style on the other. Hieroglyphic writing is now termed 'writing of the House of Life' as opposed to 'writing of documents' (or 'letters', Ⲫ), and presumably hieratic was included in the former (40, 41). The topics handled by the 'scribes of the House of Life' (first actually mentioned in Dyn. 12, No. 6) included medicine (1) and magic (23, 24, 26, 30, 36), but certainly not mere literature; some of the Late-Egyptian Miscellanies, for example, were copied out by apprentices at the Treasury, as was also the Tale of the Two Brothers. As regards mathematical treatises there is no evidence. When 'books of the House of Life' (39, *cf.* 15) are mentioned, this need not necessarily mean more than that they were compiled by scribes of that institution; certainly it does not mean that the books in question were kept there. It seems legitimate to think of the House of Life as a place of learned discussion and composition; there apparently it could be decided how the royal (10) and divine (37) titularies were to be worded; private stelae were devised there (55, 56) as well as the 'annals of the gods' (9, 10); there too interpretations (50) were given, and the conduct of festivals was determined (1). In a word, very great talent and knowledge were required (1, 43). The 'scribes of the House of Life' were indeed synonymous with 'learned men' (*rh-ht*;¹ see especially 43, also 46), and in very late times he who was so qualified boasted of himself as a 'prophet of Thoth-dwelling-in-the-House-of-Life' (43, 44, 45). A title which was associated with the ⲛⲓⲛⲓ as early as the Nineteenth Dynasty (9, 10, 17, 18, 22, 33, 46, 49) and probably also far earlier is ⲛⲓⲛⲓⲛⲓ 'scribe of the sacred book(s)', but whether every bearer of this title was actually connected with some House of Life must remain uncertain. It is clear from the wording of the Ptolemaic decrees (38) that the scribes of the House of Life were regarded as 'priests' (*wēcb*), and Peteēse, the chief prophet of Amūn at Teudjoi under Psammetichus II, allowed himself to be flattered with that title (29).

The priestly character of the said scribes did not prevent them from being active in the service of the Pharaoh, and the Peteēse just mentioned accompanied the king on his journey to Syria together with many others like him from different places. We have seen how Ramesses IV used a scribe of the House of Life in connexion with his funerary monuments (16). In important matters touching religion (37) or medicine (32) the king was apt to convoke priests from all parts of Egypt, including the scribes of the House of Life, and Ptolemy VI on one occasion made a long journey together with this multitude of theologians in order to induct a new Buchis bull (42). Or again, the entire body of priests including the staffs of the Houses of Life, ostensibly on their own initiative, assemble in solemn conclave at a given city, and thence issue a decree (38). In earlier times we find the title 'scribe of the House of Life of the Lord of the Two Lands' (11, 18), and there are other titles of a similar kind (48, perhaps 12) or cases where a scribe concerned with religious writings is shown by his titles to have been in the direct employment of the king (10, 10*a*, 17).

¹ Gauthier (*Personnel*, 11-12) conjectures that this term had a definitely religious colouring 'schant les rites'. I do not think that view is correct.

from Elephantine, and there is a reference to the *pr-ꜥnh* on another unpublished Berlin ostracon, No. 6540. On a bilingual stela in the British Museum (Brugsch, *Thes.*, 935) the title *sꜣ-st* (*Wb.*, III, 414 [6]) in the combination $\text{𓂏} \text{𓂏} \text{𓂏} \text{𓂏} \text{𓂏}$ 'magical protector of the living Apis' is rendered in Demotic by *sꜣ pr-ꜥnh*. I find also two 'scribes of the House of Life' in Griffith, *Dem. Graffiti of the Dodecaschoenus*, I, p. 304.

In discussing the word $\text{𓂏} \text{𓂏} \text{𓂏}$ (p. 171) I overlooked Weill's article on $\text{𓂏} \text{𓂏} \text{𓂏} \text{𓂏} \text{𓂏}$ *Rec. Trav.* 27, 41, where many references to the 'table of the Prince' (wrongly read by him *hkꜣt* instead of *tt hkꜣ*) are collected. Of special importance is a Middle Kingdom stela mentioned by Weill of which the owner's father was $\text{𓂏} \text{𓂏} \text{𓂏} \text{𓂏} \text{𓂏} \text{𓂏} \text{𓂏} \text{𓂏}$ 'local inspector (?) of the staff of the Treasury', whilst he himself was $\text{𓂏} \text{𓂏} \text{𓂏} \text{𓂏} \text{𓂏}$ 'commander of vessels' in connexion with the same official body, Cairo (*CCG*) 20143. Here we seem to have quite decisive evidence that the collective word $\text{𓂏} \text{𓂏} \text{𓂏}$ or $\text{𓂏} \text{𓂏} \text{𓂏}$ means 'staff' generally, is to be read *tt*, and is a derivative of the word for a 'table'.

Lastly, as regards temple libraries, Posener tells me that at Eṭ-Ṭūd blocks belonging to such a room have been found, their inscriptions giving a catalogue of the books.

THE PRESENT POSITION OF THE METROLOGY OF EGYPTIAN WEIGHTS

BY FLINDERS PETRIE

For the study of ancient weights, preparatory grouping from 1891 onward showed general outlines of the divisions into separate standards. The results were much the same as are now stated in *JEA* 23, 39–56.

By 1915, this grouping was seen to need better criteria for the distinction of the standards. This better definition superseded all the earlier grouping, which now became the mere scaffolding of the subject, and as an imperfect stage, was not useful for the general reader.

The principal lines of advance are the following: (1) The diagram of the variations of a standard must be taken separately for each separate multiple; sometimes the larger weights agree together much better than the small weights, owing perhaps to their being made professionally and not as chance required. (2) Different multiples must be taken into account, binary, or decimal, or sexagesimal as in the *Daric*. (3) The different periods must be separated by form as in *Weights and Measures*, Pl. i, repeated for popular use in *Measures and Weights*, p. 14. Thus we can see better what were the ranges of divisions in early ages, before confusion arose by careless copying. (4) Attention must be paid to the fashion of forms which indicate a common origin.

The late period of the weights of Naukratis and Daphnae makes the confused results yielded by them of no value in studying the early origin and distribution of weights.

Following such criteria, after 1915, we reach sounder conclusions as to distinction between standards.

The *peyem* is divided from the *sela* by the heavier kinds of weights. The origin is Palestinian, as fifteen examples bear the name in Phoenician, and have been mostly found in Palestine. There were three origins, about 116, 121, and 124 grs., all starting in Dynasties IV–VI, and later fused together.

The *daric* is separated by the use of 3 in the multiples and in fractions, such as $\frac{3}{10}$ or $\frac{1}{12}$, the regular Babylonian scale. A gap between values 2489 and 2502 marks the separation.

The *stater* is best delimited by a gap in each kind of weight between 130.3 and 133.4, as the average of twelve different forms. Some examples in the Twelfth Dynasty are of 134 and 136, but later there is a spread from 132 to 139.

The *qedet* is distinguished by beginning in prehistoric Semainean, as six cones give 141 to 147.6 for the unit. It was always divisible by 3, though usually decimal.

The limit between the *qedet* and the *necef* is seen in the heavy weights of 40 deben, which range from 55200 to 59750 (= 400 *qedets* of 138.0 to 151.7), and then cease. The value 152.4 may appear, therefore, as the limit, and only 5 in 800 *qedets* exceed that limit.

The *necef* belongs to Syria, and I first detected it (in 1878) in the weights of Syrian tribute to Egypt reported in *qedets*. Eight weights bear the name in Phoenician. It is northern in extension, being the unit for great gold collars from Sweden, and the same unit is found in the similar form of collar in the Seventeenth Dynasty at Thebes.

The *khoirine* weights are marked distinctively with numerals on fourteen examples; the

origin is Persian. In the single-unit weights the necef ends at 167·9 and the koirine begins at 172·4; about 168 is the best dividing-point.

The *beqa* or gold standard is a very well-marked but diffuse group. In Egypt it descends from prehistoric Amratian times. It extended to the Indus, as the common standard. There was a high group 206–216, and a low group 190–200. These were not finally fused till the Twenty-third Dynasty, yet the shape, and the same marking for 'gold', belong equally to both groups, as on examples of 189·7 and 215·3.

The Phoenician *sela* or Alexandrian standard is from 214·7 (Vapheio cups) to 227·0. It is distinguished by the clumsy and square forms of the weights.





The blurred outline of the whole mass of material was therefore by 1917 focused to precise division, when the various new criteria were introduced. This treatment resembles the use of many different reagents in extracting the several elements of a chemical compound.

All of these standards were in use from the Old Kingdom onward, and three of them are known to have been used in the prehistoric ages.

THREE OLD-KINGDOM TRAVELLERS TO BYBLOS AND PWENET

BY PERCY E. NEWBERRY

I

IN the Sixth-Dynasty tomb of Khui at Aswān (*cf.* Porter-Moss, *Top. Bibl.*, v, 235) is a short historical inscription which has not been fully comprehended by the two scholars—Breasted and Sethe—who have studied it. Unfortunately they had access only to J. de Morgan's copy published in 1894 in the *Cat. des Monuments*, i, 157, which is so inaccurate as to be, in Breasted's words, 'impossible to use'. Neither Breasted nor Sethe examined the original text at Aswān, so that it is not necessary to discuss all the emendations that they made; it will suffice to record that in 1901 Breasted¹ had recognized the name of Pwenet ('Punt') in de Morgan's blundered copy, and that two years later Sethe² had seen that Khui's name must be restored below that of Tjetji in this historical inscription. Sethe's restoration of this personal name is correct, but in the 1st edn. of his work he quite unjustifiably altered de Morgan's , given without the determinative , to  (with  and  hatched) 'Kush'; this alteration has been followed by Breasted without any question-mark in the translation of the text which he printed in his *Anc. Rec.*, i, § 361. In the 2nd edn. of *Urk.*, i, however, Sethe returned to de Morgan's reading.

When at Aswān in 1926, I myself copied the inscription and found it to be clear so far as the names of the two places visited by the travellers are concerned. My copy runs as follows:

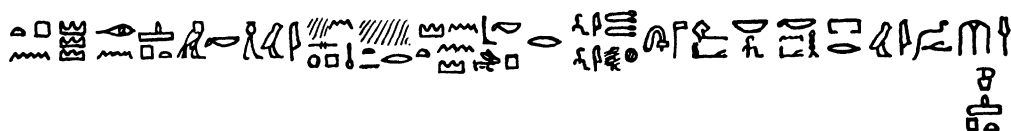





FIG. 1.



'The Director of the Kiosk, Khnemhotpe, says: I went forth with my lord, the Noble (*hsti-c*), the Treasurer of the God, {Tjetji³} to {Byblos} . . .⁴ I was brought back (?) in safety after visiting those countries.'



Tjetji's tomb (Porter-Moss, *op. cit.*, 240) was excavated in the same necropolis as that of his fellow-traveller Khui. An inscription in it records that it was he who  'brings the products of the Southern Countries to the King' (*Urk.*, i, 141), and among the persons figured in it are the 'Director of the Kiosk, Khnemhotpe' (de Morgan, *op. cit.*, 200, has  for , and ). In the tomb of Khui it is this

¹ *PSBA* 23, 238.

² *Urk.*, i, 140-1.

³ For this arrangement of hieroglyphs in a line, *cf.* *Urk.*, i, 125, line 8.

⁴ *Urk.*, i, 141, in the 1st edn. reads  'eleven times', but in the 2nd edn. .

⁵ Other corrections to be made in de Morgan's copies of the texts in this tomb are: The vertical line immediately in front of the seated figure of Khui begins  and there is no second  in his name.

Khnemhotpe who is said to have accompanied his lord on his expedition to Pwenet, and a lady Haremkawes, a daughter of Khui's wife Senti, is figured.

II

In the Wādi Hammāmāt there are two graffiti on rocks which give the name and titles of a Tjetji who is certainly the same individual as the one named in the Aswān tombs. The first simply gives the title and name 𓆎𓆏𓆑 ¹ 'the Treasurer of the God, Tjetji'. The second, a long horizontal line of hieroglyphs with some hieratic signs interspersed, reads:



FIG. 2.

'Commission executed by the Treasurer of the King of Lower Egypt, the *šmr-wtī*, the Treasurer of the God, the Commander of the Army,² the Overseer of the Hunting-Country,³ the Overseer of gold,⁴ the Overseer of all the Countries of the South⁵ . . . who sets the terror of Horus (the King) in the foreign Countries,⁶ Tjetji.'

These two graffiti at Hammāmāt were probably engraved when Tjetji was passing through the famous Wādi on his way to or from Pwenet, for it is well known that the Egyptians used this overland route through the Eastern Desert to the port of the ancient *Snw* (Košēr), and there embarked on ships for the southern land.

Although the two above-mentioned graffiti at Hammāmāt are, in my view, to be attributed to the Tjetji of the Aswān tombs, there are others in the same Wādi which possibly refer to him before he was appointed to the important office of Treasurer of the God.⁷ One of these is dated in the 18th year of the reign of Pepy I (*Urk.*, I, 93⁸). It records a Royal Commission that was executed by an Overseer of all the Works of the King, together with the Treasurers of the God, Ikhi and Iḥu, while among those who accompanied these high officials was a Master Builder (𓆎𓆏𓆑) Tjetji. This latter person is named again in a graffito on a neighbouring rock (*Urk.*, I, 95⁹) where he is given the title of Master Builder of the Pyramid (𓆎𓆏𓆑). This Royal Commission was carried out by the Treasurer of the God Ikhi, one of the two Treasurers who accompanied the expedition dated in the 18th year of Pepy I, mentioned above.

The officer burning incense before Khui is entitled 𓆎𓆏𓆑 'Director of the Kiosk'. J. de Morgan's copy of the inscriptions upon the false door is full of errors; it was correctly copied and published in 1889 by Griffith in *PSBA* 11, Pl. 1 of his *Notes on a Tour in Upper Egypt*, pp. 228 ff.

¹ Couyat-Montet, *Les Inscr. hiérog. et hiérat. du Ouādi Hammāmāt* (1912), No. 64, p. 60.

² My copy (Fig. 2), made in 1896, gives 𓆎 , not 𓆏 as in Couyat-Montet, *op. cit.*, No. 35, p. 46, Pl. x.

³ The hieroglyph depicts a man holding a throwstick, but the stick is straight, not bent, as in Metjen's tomb at Berlin (*Urk.*, I, 6). For this geographical name (apparently not recorded in Gauthier, *Dict. géog.*), see Naville, *XIth Dyn. Temple at Deir el-Bahari*, I, p. 7, and cf. de Buck, *Coffin Texts*, I, 282 h, 299 k.

⁴ My copy has 𓆑 , not 𓆒 as in Couyat-Montet.

⁵ The hieratic sign after 𓆑 appears to me to be a form of 𓆑 , but it is not like any of the early examples given by Möller, *Hierat. Pal.*, I, No. 291. Note that in the tomb of Tjetji at Aswān, Tjetji 'brings the 𓆑 ' (*Urk.*, I, 141).

⁶ For this phrase, cf. *Urk.*, I, 124, 132, 141: Mariette, *Mastabas*, 187-9.

⁷ Several 'King's Sons' of the Old Kingdom bore the title: cf., *inter alia*, Leps., *Dkm.*, II, 18-22, and Mariette, *Mastabas*, 187, 189, 191.

⁸ =Couyat-Montet, *op. cit.*, No. 107, p. 74.

⁹ =Couyat-Montet, *op. cit.*, No. 103, p. 72.

Yet another graffito in the Wādi Ḥammāmāt (*Urk.*, I, 94¹) records an expedition that had among its members the Treasurers of the God, Ikhi and Ihu, and included the  'Dignitary² concerned with the papyrus-roll, Khui', the officer whose duty it was to keep the records of the expedition. This Khui may well be the same person who afterwards bore the title of Treasurer of the God, and was accompanied by the Director of the Kiosk, Khnemhotpe, on his travels to foreign countries.

¹ Couyat-Montet, *op. cit.*, No. 61, p. 58.

² That this title does not imply elevated rank is obvious from a consideration of the officials who bore it: see *inter alia*, Davies, *Ptahhetep*, II, Pls. xxv, xxx; Gunn, *Ann. Serv.* 25, 251. Couyat-Montet, *op. cit.*, 58, errs in giving ☉ in place of ☉ in the personal name.

PYGMIES AND DWARFS IN ANCIENT EGYPT

By WARREN R. DAWSON



THE Pharaohs of Egypt and their nobles, from the earliest times, delighted to have in their households dwarfs and other mis-shapen human beings. This peculiar taste has had a very wide distribution both in space and time, and it has survived in many places until recent years. To this fancy we owe the existence of a number of pictures, statues, and drawings in the monumental records of Egypt. Many of these representations supply pathological features of great interest, all of which have a bearing upon the history of medicine.

It is curious that in the works of many modern writers pygmies and dwarfs should be spoken of almost as if they were synonymous terms. The ancient Egyptians themselves distinguished between pygmies, *i.e.* the normally small races of men from the interior of Africa, and dwarfs, which were pathological cases drawn from their own population.

Pygmies

In the tomb of Khewefhār ('Harkhuf') at Aswān there is an interesting inscription which refers to pygmies. Khewefhār made four journeys to Southern Nubia, whence he travelled westward. Three of these journeys were made in the reign of Mernerēc and the fourth in that of Pepy II, both kings of the Sixth Dynasty. Whilst on his last journey he wrote to the king reporting that he had secured a pygmy, and the king's reply to that letter is copied on the walls of his tomb. The original letter seems to have spoken of the pygmy as a wild and fierce creature continually seeking to escape, for the king's reply gives explicit directions to his official from this point of view. Reference may also have been made to a pygmy brought to Egypt by one Werdjedeba' in the reign of the Pharaoh Isesi. These references can be inferred from the king's letter, which opens with an acknowledgement of his minister's communication, and proceeds as follows:¹

'Come northward to the Residence immediately. Leave (everything ?) and bring this pygmy with thee, which thou hast brought living, prosperous, and healthy from the land of the Akhtiu,² for the dances of the god, to rejoice and gladden the heart of the king of Upper and Lower Egypt Neferkerēc, may he live for ever. When he (the pygmy) goes down with thee to the vessel, appoint trusty people, who shall be about him on each side of the vessel; take care lest he fall into the water. When he sleeps at night, appoint again trusty people who shall sleep about him in his tent: inspect ten times a night. My majesty desires to see this pygmy more than the produce of Sinai and of Pwenet. If thou arrivest at the Residence, this pygmy being with thee alive, prosperous, and healthy, My Majesty will do for thee a greater thing than that which was done for the Treasurer of the God Werdjedeba' in the time of Isesi, in accordance with the heart's desire of My Majesty to see this pygmy.'

The late Professor Breasted, in his translation, *Anc. Rec.*, I, § 353, used throughout the word 'dwarf'. The Egyptian word is *dng*, ,³ which means 'pygmy', the word for 'dwarf' being *nmi*,⁴  as we shall presently see. In commenting upon the foregoing

¹ *Urk.*, I, 129-31.

² An unknown southern people. The old translation 'spirits' is impossible.

³ In *Pyr.* it is written *dng*.

'In M.K. written , *nmw*.

inscription,¹ Breasted evidently confused pygmies and dwarfs, for he says that Khewefhâr 'returned bringing a rich pack train and a dwarf from one of the pygmy tribes of inner Africa. These uncouth, bandy-legged creatures were highly prized by the noble class in Egypt: they were not unlike the merry genius Bes in appearance, and they executed dances in which the Egyptians took the greatest delight.' He refers to two illustrations (his Figs. 41, 75), both of which represent not pygmies, but achondroplastic dwarfs. The late Sir Gaston Maspero, in an illuminating commentary on the inscription of Khewefhâr,² calls attention to the reference in the *Pyr. Texts* (§ 1189) to the *dmg* 'who dances the dance of the god', but both here and elsewhere in his writings he appears to harbour the same confusion between pygmies and dwarfs. I know of no Egyptian representations of dancing pygmies, but there is in the Cairo Museum a bronze statuette of a pygmy. This figurine has been made deliberately grotesque, but there can be no doubt that an African pygmy is intended. The artist has exaggerated the protrusion of the belly and the enlargement of the navel; these throw into contrast the lean ribs and prominent clavicles. His grotesque fancy has led him to fashion the nose crooked and the mouth awry, but the negroid characters are strongly marked.³ In the great temple of Bubastis a bas-relief represents three figures which I believe to be pygmies.⁴ They are clearly not achondroplastic dwarfs, and although of short stature—the tops of their heads just reach the level of the shoulders of the Egyptians represented in the same scene—they have well-proportioned bodies without pathological deformity, and a slight tendency to steatopygia is indicated. In his remarks on this scene the late Professor Naville confuses pygmies and dwarfs as other writers have done.⁵

Dwarfs

The Egyptian dwarfs are all, without exception, cases of the pathological condition known as *achondroplasia*, and we have evidence of these achondroplastic dwarfs in Egypt in predynastic times and throughout the historic period from the First to the Thirtieth Dynasties. Skeletons of two such dwarfs, and the humerus of a third,⁶ were found in the royal tombs at Abydos.⁷ In the same place were also found two stelae, on each of which the crude but convincing outline of a dwarf is carved.⁸ At Abydos also, the skeleton of a dwarf dating from the Fifth Dynasty was found, and this is now in the Museum of the Royal College of Surgeons in London. Another skeleton of protodynastic age was found on the site of the ancient Hierakonpolis,⁹ and yet another, dating from the Sixth Dynasty, was found by Garstang at Beni Hasan.¹⁰ Many years ago, Mariette discovered at Şakḳārah the tomb of the dwarf Khnemhotpe, and in it was found the statue, now in the Cairo Museum, which is one of the most famous pieces of Old-Kingdom sculpture, and photographs of which have been reproduced in countless books, both Egyptological¹¹ and other. From another part of the same necropolis, Quibell obtained in 1910 the granite sarcophagus of a dwarf, Djeḥo the son of Petekhons, of the Thirtieth Dynasty, on the lid of which is sculptured a full-length profile of his nude figure.¹² Early in 1927, the tomb of another dwarf, Seneb, of the

¹ *Hist.*, 139–40.

³ G. Daressy, *Ann. Serv.* 4, 124 and Pl.

⁵ *Op. cit.*, 31.

⁷ *Op. cit.*, II, 24.

⁹ Quibell and Green, *Hierakonpolis*, II, 26.

¹¹ E.g. Borchardt, *Statuen u. Statuetten . . .* (CCG), I, Pl. 32, No. 144.

¹² See Quibell and Hayter, *Archaic Mastabas (Excavations at Saqqara)*, VI, Pl. xxxv. For the texts and full description of the sarcophagus see Maspero, *Sarcophages des époques persane et ptolémaïque* (CCG), 73 ff., with Pls. vi–viii.

² *Études de Myth.*, II, 429.

⁴ E. Naville, *Festival Hall*, Pl. xx, 5.

⁶ Petrie, *Royal Tombs*, I, 13.

⁸ *Op. cit.*, I, Pl. 35.

¹⁰ Garstang, *Burial Customs* (1907), 41.

Sixth Dynasty, was brought to light in the necropolis of Gīzah.¹ In addition to these actual bones and definite historic records of dwarfs, there exists a large number of representations of achondroplastic dwarfs in the wall-paintings of tombs in various sites, as well as drawings of them on papyrus, and a series of figurines and statues.²

Dwarfs in Egypt fulfilled various offices and duties, sometimes of an important kind, but I know of no evidence whatever that they were engaged in performing sacred dances as the *dnq*, or pygmies, were. They are frequently represented in charge of jewellery (Exx. 1, 6, 18),³ or of pet animals (3, 4, 21), or in personal attendance about their masters (5, 7, 8, 9, 10). These dwarfs are generally of the male sex, females being much rarer, although in modern times achondroplasia occurs more frequently among women than among men. The dwarf in Ex. 2 stands on the prow of a boat and brandishes a sling; the female figure in Ex. 13 carries an object that seems to be a coffer, and walks behind a procession of musicians; the dwarf in Ex. 5 holds a mirror, whilst that in the figurine, Ex. 22, carries on his shoulders, St. Christopher-like, the god Bes.⁴ In Petrie's *Medum*, Pl. 24, there is a picture of a child who has been spoken of as a dwarf,⁵ because he is in charge of tame monkeys, a function frequently performed by dwarfs (*cf.* 3): his proportions are, however, those of a normal child, although the artist has deliberately emphasized his small stature in order to strike a contrast with the relatively large size of the monkeys. The dwarfs Khnemḥotpe, Seneb, and Djehō, referred to above, must have been persons of considerable importance⁶ to have been able to afford, the two former costly tombs, and the latter a massive granite sarcophagus. Khnemḥotpe bore the title of Keeper of the Royal Wardrobe, and Djehō bears a number of high titles. The important positions occupied by dwarfs in ancient Egypt is further indicated by the fact that the skeletons referred to above were found in the royal necropolis.

Generally speaking, these achondroplastic dwarfs are depicted by the Egyptians with considerable fidelity to nature. The body is muscular and thickset, the limbs short, the genitalia infantile, and the head large.⁷ In some cases there is a more or less marked degree of lordosis (1, 18, 27), but generally the spine approximates to the form of that of a normal man. In most of the drawings the heads of the dwarfs reach to the waist-level of the normal men in the same scenes. In some instances, however, the artist has resorted to a playful trick of wilful exaggeration, evidently designed to produce a striking effect. Thus in Exx. 3, 4, 21 the dwarfs are drawn on a smaller scale in relation to the animals they are

¹ Junker, *Vorläufiger Bericht in Anzeiger d. Akad. d. Wiss. in Wien, philos.-hist. Klasse*, Jahrg. 1927, 100 ff.

² 1, *Deshasheh*, Pl. 13; 2, *Op. cit.*, Pl. 5; 3, *Sheikh Said*, Pl. 4; 4, *Op. cit.*, Pl. 6; 5, *Deir el Gebrawi*, I, Pl. 17; 6, *Op. cit.*, Pl. 13; 7, *Rock Tombs of El Amarna*, II, Pl. 5; 8, *Op. cit.*, Pl. 8; 9, *Beni Hasan*, II, Pl. 32; 10, *Op. cit.*, Pl. 16; 11, *Royal Tombs*, I, Pl. 35; 12, Petrie, *Amulets*, Pl. 32; 13, Petrie, *Athribis*, Pl. 1; 14, *Royal Tombs*, II, Pl. 28; 15, *Abydos*, I, Pl. 4, fig. 11; 16, Quibell, *Hierakonpolis*, I, Pl. 18, fig. 19; 17, *Balabish*, Pl. 20; 18, *Tomb of Ptahhetep* (Paget and Pirie), Pl. 25; 19, Leps., *Dkm.*, II, 36c; 20, Garstang, *Burial Customs*, Fig. 230, p. 325; 21, Bissing, *Gemnikai*, I, Pl. 23; 22, *Macgregor Sale Catalogue* (Sotheby's, 1922), Pl. 25, lot 1310; 23, *Op. cit.*, Pl. 24; 24, Murray, *Hist. Studies* (1911), p. 40; 25, *Papyrus of Ani*, Pl. 11; 26, *Papyrus of Queen Hentowe* (Cairo): Mariette, *Pap. de Boulaq*, III, No. 23; 27, Lepsius, *Todtenbuch*, vig. to § 164 = Gunn, *Rec. trav.* 39, 102. (The foregoing memoirs, when no author's name is quoted, are EES Excavation Memoirs and Arch. Survey.)

³ These numbers refer to the references in footnote 2 above.

⁴ Cf. *JEA* 15, 1; 16, 143.

⁵ *E.g.* by Maspero, *Dawn of Civilization*, 299.

⁶ Seneb was a Prophet of Cheops and Buto, and bore a number of other titles, some of which refer to him as director of classes of dwarfs; see Junker, *op. cit.*, 106 ff.

⁷ Cf. F. J. Poynton, *System of Medicine*, ed. Allbutt and Rolleston, 1907, iii, 117 ff.

tending than can possibly have existed in nature; for in one case the standing dwarf is very little taller than the squatting monkey,¹ in the second the top of the dwarf's head does not reach to the greyhound's chin, and in the third the dwarf is scarcely taller than the greyhound and monkey he holds in leash. As already mentioned, most of the Egyptian dwarfs are males, but considerable development of the breasts is usually indicated. A pair of dwarfs, one male, the other female, habitually accompany one of the princesses in the scenes portrayed in the tombs at El-'Amarnah. They have mock-grandiloquent names and titles: the male is Parē ('the Sun') and the female Erenḥeh ('forever'), and they are called 'the vizier' and 'the queen' respectively. In addition to the usual signs of achondroplasia, they have deformities of the feet, and in the case of the male, of the head also.²

The shape of the head varies considerably. It is well known that achondroplastic infants are liable to malformation of the head during parturition, owing to its relatively large size. In some cases, the skull appears quite normal in contour, but in others it is dolichocephalic, or otherwise deformed, sometimes to a very marked degree (3, 8, 14, 25, 26). In such cases, the occipital region is sometimes rounded in form (7, 25), and sometimes square and angular (8, 26). Deformity of the skull is probably deliberately exaggerated, but it is not wise to place much reliance on this feature, for Exx. 7, 8, both of which represent the same individual, reveal two different cranial contours. The head of Djeho is in contrast with all the others, for the brow is high, the top of the head elevated and domed, and its form suggests that which sometimes results from malposition during parturition, *i.e.* through occipitoposterior presentation.

The legs are often bandy, and this is a common feature of achondroplasia (9, 10, 14). The form of the dwarf at Beni Ḥasan (9) suggests rickets, but the square muscular build and short arms make it more probable that ordinary achondroplasia is intended, and that the bowing of the legs is exaggerated, an inference which is confirmed by the word *nmw* (𓏏𓏏𓏏) 'dwarf', written above the figure.

Achondroplastic dwarfs must have had magical significance, and for this reason figurines and amulets were formed in their shape from the earliest times (12, 16, 20, 22, 23). In a magical papyrus at Leiden there is a spell to facilitate birth, called 'The Spell of the Dwarf'. At the end of the incantation is the rubric: 'Say the words four times over a dwarf of clay placed upon the vertex of the woman who is giving birth.'³ In another magical papyrus there is a spell in which a dwarf is invoked: 'O thou dwarf of heaven! O thou dwarf of heaven! Thou dwarf whose face is big, whose back is long and whose legs are short.'⁴ The picture accompanying the 164th spell of the *Book of the Dead* represents the body of an achondroplastic dwarf with a Janus-head—the face looking forwards is that of a falcon, and that looking backwards is human. The arm is raised in the attitude of the god Min. In the remarkable series of pictures of divinities seated in shrines which accompanies the 147th spell of the *Book of the Dead*, one is the seated figure of an achondroplastic dwarf (e.g. *P. Ani*, Pl. xi), and a similar figure sometimes occurs in funerary papyri of the Twenty-first Dynasty (26). The last three examples, although mythological subjects, are clearly based upon human models, with the exaggeration needed to produce a terrifying appearance, for they are all denizens of the underworld.

¹ It is a *Cercopithecus* monkey, which in the attitude depicted could scarcely have exceeded a height of 18 inches.

² These dwarfs occur many times in the tomb-scenes: of Paneḥasy (*Rock Tombs of El Amarna*, II, Pls. 5, 8); of May (*op. cit.*, v, Pl. 3); of Ay (*op. cit.*, VI, Pls. 17, 26, 28).





³ *P. Leiden*, I, 348, 12, 2-6.

⁴ *P. Mag. Harris*, 8, 9-10; Gunn, *Rec. trav.* 39, 102.

Another indication of the respect in which dwarfs were held in Egypt is provided by a sentence of the Teaching of Amenemōpe, in which the sage says: 'Laugh not at a blind man, nor tease a dwarf.'¹ Finally, it may be mentioned that the personal name *Pꜣ-nmī*, 'the Dwarf', occurs frequently in an Eighteenth-Dynasty account-papyrus in the British Museum.²

I am indebted to Professor Gunn for a revised translation of the text in the tomb of Khewefhār and for some valuable references.

ADDITIONAL NOTE

In stating above that I knew of no records of dwarfs performing sacred dances, I had overlooked the passages quoted by Gardiner, *Notes on . . . Sinuhe*, 70 (to *Sinuhe* B, 194-5). In the first of these (Mariette, *Mon. Div.*, 61) reference is definitely made to dancing (*hbb*) at the door of a tomb, performed by dwarfs (*nmīw*). The second instance (Ptolemaic) is similarly worded, but 'dwarf' is here not spelt out, being written simply with the word-sign  which might as well stand for *dng* as for *nmī*. It is well known that amongst the funerary ceremonies a dance was performed by men wearing a peculiar head-dress, the *mw* as they were called, and it seems probable that in the first-mentioned text (N.-K.) the scribe confused the writing of  *mw* with  *nmw*, the usual M.-K. writing, which he transcribed into the current spelling . Concerning this possible confusion of words, see Gardiner's note, *loc. cit.*, and as to the *mw*-dancers, see Davies-Gardiner, *Tomb of Amenemhēt*, 51, n. 3.

It is hardly likely that the 'dance of the god', in which the king took so keen an interest, should refer to one of the routine funerary ceremonies which were performed for private individuals. The true pygmy-dance is much more likely to have been a temple-ritual. There are many painted or sculptured scenes representing the *mw*-dancers in tombs of all periods, but there is not a single instance, so far as I am aware, of a picture of the 'dance of the god', which must have been a very rare occurrence—only performed, in fact, upon the infrequent occasions when a pygmy could be procured to do it.

¹ *P. BM. 10474*, 24. 9 (cf. *JEA* 12, 221).

² *P. BM. 10056*, *recto* 5, 3 and often (Glanville, *ZÄS* 68, 34).

THE STELA OF THE SCULPTOR SIRĒC AT OXFORD

BY A. N. DAKIN

THE stela to be discussed in the following pages now stands in a prominent position in the Egyptian room at the west end of the Ashmolean Museum (ground-floor).¹ It was discovered during Professor Garstang's excavations near Er-Reḳāḳnah in 1901–2,² and published with brief comments and a partial translation by Professor Newberry in *Tombs of the Third Egyptian Dynasty*, Appendix A, p. 66 (photographs of front and back, Pl. 33).³

Viewed from the front (Pl. xii), this stela seems only to need to have its edges trimmed off to be a regular example of the round-topped Twelfth-Dynasty type.⁴ But the back is very unusual, showing a figure of the owner in high relief on a sunken panel, not centred, but noticeably to the right of the vertical axis, surrounded on three sides by inscriptions. The rest of the back (about four-fifths of the whole space) is left quite rough.⁵

The stela is of limestone, and its dimensions are: height from present base, 0·813 m. (32 in.); maximum width, 0·515 m. (20¼ in.); thickness varying from 0·12 to 0·16 m.; smoothed portion at back, 0·31 × 0·26 m.; the sunken panel is 0·22 × 0·14 m. and is cut back to a depth of from 0·020 to 0·025 m. The front is very well preserved, except for the breaks at the bottom and a patch to the left of the centre in the second register, where the figures and hieroglyphs have been damaged by rubbing. On the back, the main figure has been damaged, and it seems that an incised figure of a man in the posture of adoration has been scratched out below the right vertical column of inscription.

The style and workmanship of the front of the stela are very good: the figures (all in sunk relief) are well drawn and the detail of wigs, etc., has been put in very thoroughly (though no doubt it was, as so often, obscured by paint, of which perhaps a few traces remain); the composition of the scenes is pleasing except in the lowest register of all, where, as frequently happens, a rather too numerous collection of miscellaneous people has been crammed into a small space. The hieroglyphs are for the most part well made, though often reversed or awkwardly arranged.

¹ I wish to thank Mr. D. B. Harden of the Museum, who kindly gave me permission to study this stela for publication. Its number is E. 3921.

² Actually in remains of houses of the Roman period at Bēt Dāwūd Sahl, 16 km. north of Abydos, see Garstang, *op. cit.*, 12.

³ Since these photographs were taken the lower parts of three names in the lowest register have broken away. The stela is now set rather too low in its base, so that the bottom framing-line is out of sight near the right-hand end.

⁴ 'Round-topped' stelae with the corners cut back a little and then left square are not unknown, *e.g.* even on the very fine Leyden stela V 3 the top corners have been only half-heartedly chamfered off.

⁵ In view of the general appearance of the back (which can be seen in Garstang's original publication, Pl. 33) it seems hardly likely that the whole of it was exposed when the stela was set up. Along the top run three or four saw-cuts, which suggest that the owner may have tried to separate the two faces—though this would have left two very thin slabs. Perhaps the likeliest explanation is that the stela was let into the thickness of a wall in such a way that the whole of the front was visible on one side while only the inscribed panel of the back showed through a hole on the other side. In such a case there might be no need to trim the edges or smooth down the rest of the back.

On the back there is scarcely any interior detail in figures or hieroglyphs, and the latter are much less carefully disposed and cut.

There does not seem to be any evidence pointing to a precise date, but I have found nothing to contradict Garstang's ascription to the Twelfth Dynasty.

The principal person,¹ in whose honour the stela was carved, is a sculptor named Sirĕc:² he appears on the left of the first register, and again he is the figure in relief on the back panel. Most of the other people represented are relatives or fellow craftsmen. The fact that Sirĕc himself is said to 'cause to live' the names of several of these relatives makes it quite clear that he had the stela made during his own lifetime. Sirĕc's family would seem to have been particularly attached to the god Khentekhtay, if one may judge from the numerous names having that god's name as one element, though it must be admitted that names so formed are very frequent in the Middle Kingdom.

THE INSCRIPTIONS AND SCENES³

A. Front

The first five lines, which fill the lunette, read as follows: *Adoration to Khentamentiu in the great procession,⁴ when the god is ferried across to Peĕr,⁵ and seeing the beauty of Wepwawet in the first procession in Shen-Hor,⁶ by the sculptor Sirĕc,⁷ by the sculptor Djehuti,⁸ by his father Khentekhtayemĕt,⁹ (by) his brother the sculptor Sebekhotpe,¹⁰ by Sirĕc,¹¹ by Ekhtay,¹²*

¹ Or persons, for, as suggested below, p. 196, there may have been two sculptors named Sirĕc.

² 'Son of Rĕc', a not uncommon name, though a rather surprising one, being one of the most important titles of the king. (All the names found on this stela are given in Ranke, *Die äg. Personennamen*, except where the contrary is stated.)

³ I wish here to thank my teacher, Professor Gunn, who first suggested to me that I should work on this stela, for his kindness in helping me with some points in relation to the proper names.



⁴ In the 'mysteries' at Abydos, see Schäfer, *Unters.*, iv, 68.

⁵ The site of the tomb of Osiris, deriving its name from that of a legendary tree, see Schäfer, *ZÄS* 41, 107 ff. *Wb.*, I, 561 (6) does not show this writing without the final consonant as a Middle-Kingdom one.

⁶ 'The . . . of Horus', elsewhere more often written with honorific inversion, seems to have been, like Peĕr, of special significance in the Osiris-legend at Abydos. Gauthier, *Dict. géog.*, 5, 139, quoting only the examples from Petrie, *Athribis*, Pl. 13, suggests that it may be a name for the necropolis of Athribis. But in other examples (*e.g.* Louvre C. 3, l. 14; Munich Glyptothek 40, l. 14, in Dyroff-Pörtner, *Aeg. Grab- u. Denksteine aus südd. Sammlungen*, II, Pl. 2, No. 3 = Sethe, *Lesest.*, 74, 11, where given as Glyptothek 27; *Hierogl. Texts BM*, II, Pls. 5, 6) it occurs in what must be, as *Wb.*, iv, 497 (3) takes it, the name of a festival or ceremony at or near Abydos (*May he hear the rejoicing at R-n-Tȝwr, and the Hȝkr festivity on the night of sleeping the sleep (sĕryt) of Shen-Hor*). On our stela, as in the practically identical phrase on Cairo 20516 c, it is the place of the 'first procession' in the Osirian 'mysteries' in which, as described by Ikhnofret, the god Wepwawet goes to aid his father Osiris. It is thus natural that Wepwawet should be  in the *Athribis* examples. Was the *sĕryt* a commemoration of a bivouac after the battle with Osiris's enemies?

⁷ This third line offers an interesting example of specialized *ad hoc* determinatives, as found fairly often in the O.K. Here, as 'adoring' is in question, we get men in the recognized posture of adoration, instead of the regular 'seated man'.

⁸ Named after the god Thoth.

⁹ 'Khentekhtay is to the fore'; the unusual writing  of the element *-hty* of the god's name is, as Prof. Gunn has pointed out to me, evidence that the element is a *nisbe*-form from *ht* 'belly'. Cf. the earliest known writing of the simple name *Hty*  in *Urk.*, I, 152, 7 (although here in the O.K. the presence of the two reeds is unusual in a *nisbe*-form).

¹⁰ 'Sobk is kindly.'

¹¹ Presumably not a repetition of the chief person.

¹² 'The paunchy (?)', cf. n. 9 above, and *JEA* 23, 5, n. 5.

Khentekhtayemhēt,¹ *Khentekhtayhotpu*,² and *Khentekhtayhotpu*. An offering which the King gives to Osiris, Lord of Busiris,³ Chief of the Westerners, the great god, Lord of Abydos, and (which the King) gives to Wepwawet, the Power of the two lands,⁴ Lord of the Sacred Land, and to Anubis who is in front of⁵ the god's shrine; (namely) a funerary offering of bread and beer, a thousand of oxen, a thousand of geese, a thousand of alabaster and clothing for the honoured one, the sculptor, *Sirē*, born of *Hotpu*.⁶

Next follow the four main registers. The first register comprises two scenes; the left-hand scene shows: *The honoured one, the sculptor Sirē, possessor of honour, and his beloved wife*⁷ sitting together before a table, while food is offered to them by his brother *Khentekhtay-hotpu*,⁸ in the right-hand scene sit his brother, the sculptor *Sebekhotpe, possessor of honour*,⁹ and his wife *Sitsenmeri*;¹⁰ above their offering-table is written: *A funerary offering of bread and beer, oxen and geese, and the offerer is his brother Senmeri*.¹¹

Above the second register runs a line of inscription as follows: *An offering which the king gives to Osiris, the great god, Lord of Abydos, that he may give a funerary offering of bread and beer to the honoured Djehuti; it is his son who causes his name to live, the sculptor Sirē, justified*. On the left of the register itself the three seated figures are his father, the sculptor *Djehuti, possessor of honour with his daughter Sitsenmeri* and his mother *Hotpu*, while facing them across the table stand his son *Senmeri* in the regular attitude for pronouncing the offering formula (but perhaps it is not the formula written above, which is ascribed to *Sirē*), his son *Ekhtay, his daughter Sitsenmeri*¹² and his brother *Intef*.¹³

The third register closely resembles the second. Its superscription runs: *An offering which the king gives to Wepwawet, the Power of the two lands, Lord of the Sacred Land, (namely) a funerary offering of bread and beer, a thousand of oxen and geese for the honoured one Khentekhtayemhēt. It is his son who causes his name to live, the sculptor Sirē*. The three seated figures on the left are his father *Khentekhtayemhēt, his wife Hotpu* and his daughter *Sitkhentekhtay*¹⁴ and facing them stands his son *Khentekhtayemhēt, plucking a fowl, and then follow three women, his daughter Sijdjehuti*,¹⁵ his daughter *Sekhathor*,¹⁶ and his sister *Merusi*.¹⁷

The fourth register resembles the first, consisting of two scenes, each showing a seated

¹ No doubt the son of the other bearer of this formidable name.

² 'Khentekhtay is kindly'; of these last two one appears in the first register, the other in the fourth. Below, where space allows, the ending *-w* of the Old Perfective is written.

³ A much abbreviated spelling of *Ddw*.

⁴ A not very frequent title of Wepwawet occurring again below; cf. also, e.g. *Hierogl. Texts BM*, v, 5, Budge, *Lady Meux Collection*, Pl. IX D (Dyn. 18), Leyden V 104 (twice), and Cairo 20025 a, 2, the latter two examples having been unnecessarily ascribed to Anubis by their editors. A debased form $\begin{smallmatrix} \text{𓂏} \\ \text{𓂏} \\ \text{𓂏} \end{smallmatrix}$ occurs on a late stela in Mogensen, *Stèles ég. au Mus. Nat. de Stockholm*, p. 71.

⁵ *Hnty* here with det. 𓂏 , which *Wb.*, III, 304 does not show as found before the N.K.

⁶ Apparently *htp(w)*, = 'food, offerings' (*Wb.*, III, 184) as a proper name, but cf. p. 194, n. 6, below.

⁷ Thus the wife is given no name.

⁸ Note the unusual writing of *-hty* with 𓂏 .

⁹ *Nb imsh*, broken but unmistakable.

¹⁰ 'Daughter of Senmeri.'

¹¹ A name difficult to explain, in view of the alternative writing with $\begin{smallmatrix} \text{𓂏} \\ \text{𓂏} \\ \text{𓂏} \end{smallmatrix}$.

¹² Who thus seems to be shown twice in the same scene.

¹³ 'He who brings his father'; cf. Erman, *ZÄS* 39, 147, and the feminine counterpart *Int-it-s*.

¹⁴ 'Daughter of Khentekhtay.'

¹⁵ 'Daughter of Thoth.'

¹⁶ Named from the cow-goddess who suckled Horus.

¹⁷ For *mr-wy sy*, 'How beloved is she!'? Apparently not found elsewhere.



THE STELA OF SIRĒ': FRONT.

Ashmolean Museum No. E.3921.

(Scale c. 1 : 4).

couple receiving food offered by a third person. To take first the left-hand scene, the inscription above reads: *An offering which the King gives to Wepwawet,¹ that he may give a funerary offering of bread and beer, a thousand of oxen and geese to the Ka of the honoured SirĒꜥ, justified;*² then above the table, *It is his son's son who causes his name to live, SirĒꜥ, justified.* The seated figures are, *the honoured SirĒꜥ, justified* and *his wife Sitkhentekhtay*, who is smelling an unguent; before them stands *his son Khentekhtayhotpu* who is saying *An offering which the King gives, a thousand of bread and beer, a thousand of oxen and geese.* In the right-hand scene the inscription above runs: *An offering which the King gives to Osiris, Lord of the Thinite Nome, (that he may give) a funerary offering of bread and beer, a thousand of oxen and geese to the Ka of the honoured Ekhtay*, and over the table, *It is his daughter's son who causes his name to live, the sculptor SirĒꜥ.* The seated man is *the honoured Ekhtay, justified* and the woman who grips his arms so possessorially is *his wife, Sitrereru.*³ The offerer in front of their table is *his daughter Sitpepy,*⁴ who says: *An offering which the King gives, a thousand of bread and beer, a thousand of oxen and geese.*

In the lowest register of all SirĒꜥ himself⁵ is shown twice, on two seats facing in opposite directions,⁶ between which his parentage on the maternal side is inscribed, *ms-n Ḥtp(w)*. To the left the offering formula, which reads *An offering which the king gives to Osiris and to all the gods of Abydos,⁷ (for) the honoured SirĒꜥ, born of Ḥotpu*, is spoken by *his brother Intef*. Further left stand three figures: first a woman with the inscription *his mother, Netabḏju-Sitwepwawet,*⁸ then two men, *the sculptor Wānesh,⁹ and Sisekhathor.*¹⁰ To the right of SirĒꜥ as he sits facing right stand five persons. First a man whose name is broken away, who recites the formula, *An offering which the king gives, a thousand of oxen and geese (for) the honoured one, the sculptor SirĒꜥ, born of Ḥotpu.* Next comes *his brother Khentekhtayemḥēt (?)*,¹¹

¹ Here the word-sign is written mistakenly before the phonetic signs.

² Appearing abnormally before the name.

³ 'Daughter of Rereru', apparently not found elsewhere. Probably a variant or an erroneous spelling of *Sit-rrw*.

⁴ 'Daughter of Pepy.'

⁵ Here the writing () seems to hesitate between honorific inversion and an order of signs corresponding with the pronunciation.



⁶ A quite unusual arrangement, for which I cannot quote any good parallel. It is difficult to see why he should not have been shown in the usual place of honour at the left-hand extremity of the register. Did the artist feel that this register, like the others, ought to have a break in the middle? Though, if symmetry was the main consideration, we might have expected registers 2 and 3 also to have the seated groups in the middle.

⁷ Probably not 'the gods, lords of Abydos', as *nb(w)* has no plural det.; for the clear plural *nbw Wb., II, 360* gives both renderings.

⁸ 'She of Abydos, daughter of Wepwawet.' Probably *Nt-ḏḏw* is here the first part of a double name (cf. those discussed *JEA* 23, 2, n. 1, among which *Meketherhab-Yebiꜥo* is likewise a woman's name) and she is *Intef's* mother but not *SirĒꜥ's*, i.e. either a subordinate wife of *SirĒꜥ's* father or one whom he married before or after *Hotpu*. So *Intef* would be *SirĒꜥ's* half-brother on the father's side, for which we might have expected *sn-f n it-f*, on the analogy of *sn-f n mwt-f* which occurs in *Spiegelberg-Pörtner, Aeg. Grab- u. Denk-stelle aus südd. Sammlungen*, I, Pl. 8, extreme right-hand figure in second register.

⁹  usually rendered 'Wolf'.

¹⁰ This name, 'Son of Sekhathor' (see p. 192, n. 16, above), is not in *Ranke*, but appears among *J. J. Clère's Notes d'onomastique in Rev. d'égyptol.* 3, 111. One would have expected to find honorific inversion.

¹¹ So *Garstang*, whose photograph, which unfortunately is indistinct at this point, seems to show , but so placed that there seems to be no room for  too. Could the last element have been *-sh̄m*? This name and the next have been damaged since that photograph was made.

then *his sister Sītkhentekhtay*,¹ and finally two men apparently not related to Sirēc, *Senmedu*² and *Yefen* . . .,³ the end of whose name is lost.

B. Back



The back of the stela (see Pl. xiii, 1, and Garstang, *op. cit.*, Pl. 33) is very unusual in appearance; in its general arrangement it might be said to show a remote resemblance to a Sixth-Dynasty type of false door, but I have not been able to find any reasonably close parallel. The workmanship on the whole is definitely not so good as that of the front. The figure in relief, whose head and legs have suffered much damage, is *the honoured one, the sculptor Sirēc*. Above, on the left, he is represented sitting at a table, and the inscription reads: *The one who is in honour⁴ with the Great God, the Lord of Heaven, may he give⁵ a funerary-offering of bread and beer, oxen and geese, alabaster and clothing, to the Ka of the honoured one, the sculptor Sirēc, born of Hēpwet,⁶ possessor of honour.*

Below the right-hand vertical column of inscription Sirēc himself will have appeared again, but his figure has been deliberately scratched out. Above are the words *Adoration to Osiris, the great god, Lord of Abydos, (by) the one who is in honour with the king, the sculptor Sirēc, possessor of honour.* On the left side his father stands in the posture of adoration, with the inscription *Adoration to Wepwawet, Lord of the Sacred Land, by his father Khentekhtayemhēt, possessor of honour.*

The relationships of the persons depicted are not all clear; as Garstang pointed out, Sirēc seems to have two fathers!⁷ The main difficulty is to know to whom we are to refer the suffix *·f* ('his'), attached to some of the chief figures in the lower registers; and this difficulty is most acute in the cases of the two 'fathers', Djehuti and Khentekhtayemhēt, and the two 'mothers', Hōtptu at the extreme left of the second register, and the one who follows Intef in the bottom register. Everywhere else there seems to be little reason to doubt that 'his' refers to the chief figure in the scene in question. In the case of the two

¹ So Garstang's photograph.

² 'The man of the staff' (a name not in Ranke), the staff regarded as a divine being (cf. Spiegelberg in *Rec. Trav.* 25, 184 ff.), though not enjoying honorific inversion. The name is slightly damaged at the bottom (and has suffered from the common tendency of Egyptian stone-cutters to make odd signs face right in a word which as a whole faces left) but apparently should read . As Prof. Gunn points out to me, this must be the Middle-Egyptian equivalent of the frequent Late-Egyptian name *Ns-pi-mdw*, 'He belongs to the staff', which appears in Gk. as *Ἐσπιμηδῆρις* and in Assyrian as *Išpimātu* (cf. W. Max Müller, *ZÄS* 31, 127). Similarly we find *S-n-Pth* = *Ns-Pth* and *S-n-Hr* = *Ns-Hr*, though the forms in *S-n* seem to be much less frequent (excepting, of course, *S-n-Wsrt*) than those in *Ns-*. In the present case does the very full writing of *mdw* imply that the name is of O.-K. origin?

³ The first three signs are clearly  (probably an abbreviation of *iw·f n*) and just above the break there appears to be the top margin of another sign. There is very little left, but what remains might be interpreted as the top of , suggesting *iw·f n mwt·f*, 'He belongs to his mother', or some similar name.

⁴ The signs are out of order; presumably we are to read .

⁵ It is rather surprising to find the offering-formula after what seems to be a title; was the scribe misled by *ntr* , *nb pt* into continuing as if *Htp di nsu Wsir* had preceded?

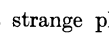
⁶ , a strange phonetic writing for ; perhaps further evidence for the metathesis *htp* > *hpt*, suggested in Firth-Gunn, *Teti Pyr. Cem.*, I, 110, n. 17; although Ranke, *op. cit.*, 260, 12, apparently regards this final *-t* as genuine, and omitted from the other writings, the true reading to be *Htpwt*. Cf. also his note, p. xxvii, to 257, 22.

⁷ The stelae Cairo 20155 and *Hierogl. Texts BM*, II, Pl. 15, seem to be parallel cases: in the latter the chief figure seems to have two wives and two fathers, although as one of the fathers is in the unfinished bottom left corner he may be an uncorrected mistake.



1. Stela of Sirē : back.

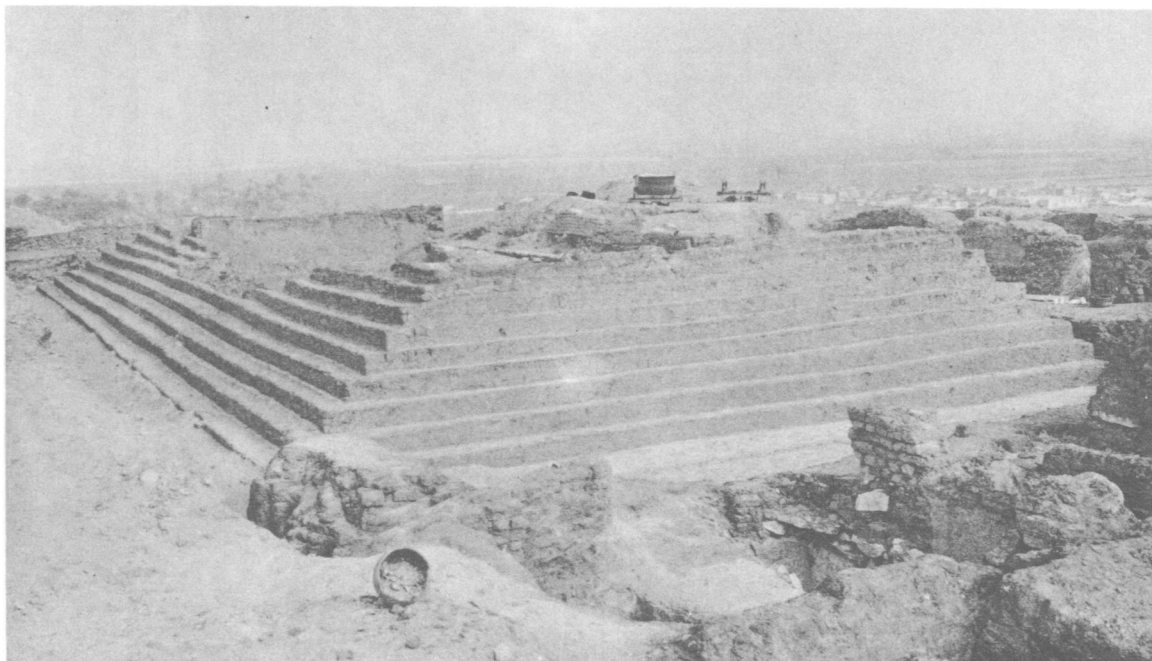

2. Tomb of Nebetka at Saqqarah (see p. 243).

fathers we should naturally take 'his' to mean 'Sirēc's', as he has just been mentioned in the offering-formula above them, but plainly some reinterpretation is necessary.

But first we must discover what certain information the stela offers, by considering each register in turn. The first register yields the following scheme (.....indicating the relation of brother to brother, brother to sister, etc. where the parents are not stated, * indicating a woman):

Khentekhtayhotpu.....Sirēc = ?* Sebekhotpe = Sitsenmeri* Senmeri

In the above presumably 'his brother' as applied to Sebekhotpe will mean Sirēc's brother, to judge from the third line of the lunette, where the former is again 'his brother' in a line of people headed by Sirēc; in that case whether Senmeri is brother to Sirēc or Sebekhotpe comes to the same thing as far as we can tell.

From register 2 we get:

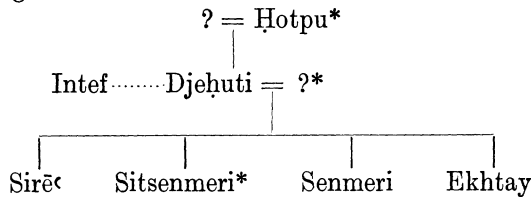

In the third register we meet a different set of people:

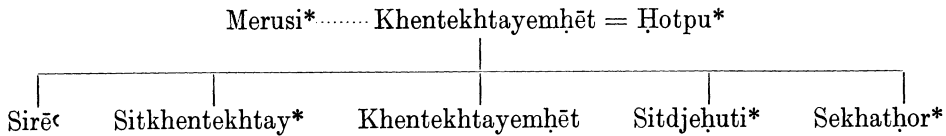

The fourth register shows two sets of grandparents of a Sirēc, with a son offering to the paternal grandparents, and a daughter to the maternal. In such a case it seems most reasonable to assume that the son is father and the daughter is mother of the Sirēc in question. On that hypothesis we can link up the two scenes of register 4 as follows:

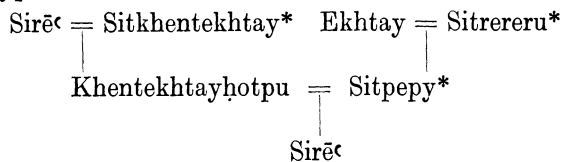

This grandson Sirēc cannot well be the Sirēc for whom the formula in the lunette is written, for the latter's mother is Hotpu, and we cannot tell whether the grandfather Sirēc is the man in register 1, for there the wife is nameless; he might be the Sirēc aforementioned of the lunette, though, in that case, we might have expected him to be called 'sculptor'.

For the two halves of register 5 we can draw up the following schemes: (a) Left-hand half:

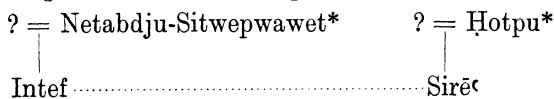

(b) Right-hand half:

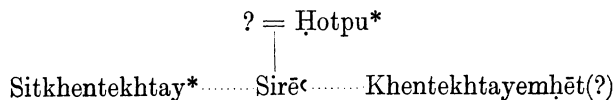

All that the back of the stela has to tell us is

Khentekhtayemhēt = Hēpwet (presumably = Hōtpu)*

|
Sirē^c

which was almost deducible from the third register.

When we try to combine the data of the various registers we find that registers 3 and 5 and the back all have Sirē^c, Hōtpu and one of the Khentekhtayemhēts in common, and will therefore form the best starting-ground for a general scheme, while registers 1 and 2, whose personnel is rather different, are united in another scheme. Register 4 is very difficult to fit in, and must be set aside for the moment. Registers 3 and 5 and the back, then, yield:

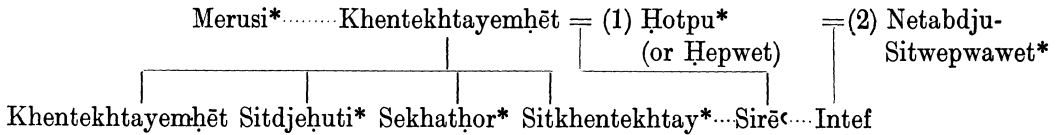

We might try to link up the refractory material of register 4 with the above scheme by supposing that Sirē^c married his sister Sitkhentekhtay, and that Khentekhtayhotpu was their son and the other Sirē^c their grandson, also a sculptor. But there are two serious difficulties in the way of this combination: firstly, as mentioned above, we should have expected the elder Sirē^c to be called 'sculptor', and secondly, if he was really married and had a son and grandson, it is surely surprising that no other children of his appear.

Registers 1 and 2 give the following combination:

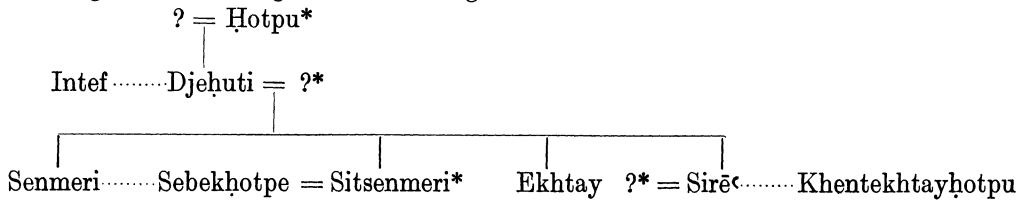

It is evident at the first glance that this second table is (supposing the same name to refer to the same person) quite incompatible with the first. In the one, Sirē^c is brother, in the other, nephew to an Intef; and in one Hōtpu is Sirē^c's mother, in the other his grandmother.

Any attempt to harmonize the apparently discrepant data is hazardous and must be recognized to be quite conjectural, but it may be allowable to suggest two possible lines towards a solution.

One method would be to postulate two Sirē^cs (or, more precisely, three, including the grandson in register 4, who must be other than the bearers of the same name in registers 1 to 3). One would be the Sirē^c of our second table, who appears in registers 1 and 2, and is son of Djehuti and so apparently grandson of Hōtpu, while the second would be son of Hōtpu (so given in register 5) and so by inference brother, or at least half-brother, of Djehuti, though that is not stated, as this supposed second Sirē^c and Djehuti do not appear together anywhere.

The other method involves another relaxation of our principle that 'his (brother, etc.)' refers to the chief figure of the register or part of register in question, but otherwise it is not unreasonable. It is to suppose that 'father' can be used loosely, as it is in English, to mean 'step-father'; then we need not multiply Sirē^cs but can suppose that the one who was actually son of Khentekhtayemhēt and Hōtpu called himself son of Djehuti because Hōtpu

after the death of Khentekhtayemḥēt had married Djehuti; then we must take it that she is called 'his mother', meaning 'Sirēꜥ' s mother', in register 2 because her relationship to Sirēꜥ was felt to be more important than her relationship to Djehuti.

Either of these suggested methods would allow us to produce a family tree without any great improbabilities, combining our two previous schemes, but whether either of them would reproduce the set of relationships no doubt quite clearly understood by the original author of the inscription is a question which must be left quite open.

POISONS IN ANCIENT EGYPT

By A. LUCAS

It is commonly stated in books on toxicology that the ancient Egyptians used prussic acid (hydrocyanic acid) as a poison. These statements may all be traced back to the alleged translation by Duteil of a passage in 'an extremely ancient papyrus in the Louvre', which is as follows: 'Ne prononcez pas le nom de IAO, sous la peine du pêcher' ('Speak not the name of IAO'—one of the Hebrew names for God—'under the penalty of the peach-tree').¹ Mr. Alan Rowe tells me that this papyrus must be attributed to a Gnostic.

Commenting on this passage, R. A. Witthaus says² 'it would be difficult to draw any other inference than that the Egyptian priests were acquainted with the preparation of a poisonous substance (hydrocyanic acid) from peach leaves or kernels with which those who betrayed the secrets of the priesthood were destroyed'. Wynter Blyth is more emphatic and states³ that 'The Egyptians knew prussic acid as extracted in a dilute state from certain plants, among the chief of which was certainly the peach'.

It may be pointed out, however, that although the peach-tree is grown to a small extent in gardens in Egypt, it is not indigenous and was only introduced into the country at a comparatively late date, probably from Persia. With respect to this, Pliny says⁴ that 'It is quite untrue that the peach which grows in Persia is poisonous and produces dreadful tortures, or that the kings of that country, from motives of revenge, had it transplanted in Egypt. . . .' Newberry found peaches and a large number of peach stones in the material from the Graeco-Roman cemetery at Hawara.⁵

Many magical texts on papyrus and stone, of the New Kingdom and later, contain spells against poison; in most cases it is clear that the poisoning has resulted from the bite of a snake or the sting of a scorpion, and in the others, *e.g.* the magical Papyrus No. 36 of the Vatican,⁶ where the nature of the poison is not specified, we have no reason to assume that it was artificially produced and was not the result of one of the two natural injuries just mentioned.

Maspero says⁷ of an Egyptian mummy of a young man, whom he calls 'prince sans nom' that 'tous ceux qui l'ont vue ont supposé sur le champ que le prince qu'elle représentait avait été empoisonné. La contraction du ventre et de l'estomac, le mouvement désespéré par lequel la tête se rejette en arrière, l'expression de douleur atroce qui est répandue sur la face ne peuvent guères s'expliquer que par cette hypothèse. Les bras et les jambes avaient été tordus par la souffrance.' Even though the 'prince' had died in agony, there is, of course, no evidence whatever that he had been poisoned; and again, if poison was the cause of death, it may have been from snake-bite.

¹ F. Hofer, *Histoire de la chimie* (1842), I, 226. [It has not been possible to trace this quotation. Hofer, *loc. cit.*, merely says 'selon M. Duteil, auteur d'un *Dictionnaire des Hiéroglyphes*, on lit sur un des papyrus du Louvre 'ne prononcez pas. . . .' Nothing of the kind seems to be stated in Duteil's *Dictionnaire*. Sir Herbert Thompson kindly informs us that neither in the single demotic magical papyrus (No. 3229) nor in the three Greek magical papyri (latest edn. Preisendanz, *Griechische Zauberpapyri*, I, II) of the Louvre, is there any such statement.—Ed.] ² *Manual of Toxicology* (1911), 5. ³ A. and M. Wynter Blyth, *Poisons*, 2.

⁴ *Natural History*, xv, 13.

⁵ Petrie, *Hawara, Biahmu, and Arsinoe*, 48, 50.

⁶ É. Suys, *Le Papyrus magique du Vatican*, in *Orientalia* 3, Nova Series, Fasc. I, 1934.

⁷ *Les Momies royales de Déir el-Baharí*, I (1889), 549; Pl. ix.

Herodotus states¹ that 'Psammenitus, son of Amasis', 'plotted evil and got his reward; for he was caught raising a revolt among the Egyptians; and when this came to Cambyses' ears, Psammenitus drank bulls' blood and forthwith died'. A footnote by a translator, A. D. Godley, states that 'The blood was supposed to coagulate and choke the drinker'.

Reisner² found in a tomb at Nag' ed-Dêr, probably dating from the First Intermediate Period, about twenty reed arrows and about the same number of bone arrow-heads, three of which had barbed or serrated tips. All the tips were blackened. There were also three cases made from reeds for containing arrow-heads so that they might be carried without danger to the owner. 'The form and size of the reed shafts and the bone points leave no possible doubt that these were poisoned arrows of a type well known in use among African and South American tribes. The blackened tips confirm this conclusion. The blackening was probably only colouring matter used by the maker of the arrows in order to mark clearly the tips which had been poisoned from those which had not yet been prepared. The material was not analysed, but it is doubtful if any trace of the original poison would have been found.'

Petrie states³ that 'The arrow points of ivory are common in the earlier part of the 1st Dynasty. . . . They are often tipped with red ochre, which has been supposed to be a poisoned tip. . . .; probably the red colour was put on with the idea of sympathetic magic, in order to draw the arrow to the blood of the animal at which it was shot'.

Mr. W. B. Emery, of the Egyptian Antiquities Department, recently found, in a First-Dynasty tomb at Şakkārah, a large number of ivory-tipped arrows, about sixty of which were coloured red at the points.⁴ A few of the latter were submitted to the writer for examination. The length of the red-coloured portion varied from about 6 to about 13 mm., with a mean of 10.75 mm. (0.42"). The colour, which was a thin paint, and not a stain, was easily removed by means of both water and hydrochloric acid and consisted entirely of red oxide of iron (red ochre), and showed no evidence of either organic matter or poison. It is probable, therefore, that this colour was merely symbolic.

Various plants containing poisonous substances grow wild in Egypt at the present day, and probably have done so from very early times. The two principal of these are several species of *Datura*, including *Datura stramonium* (thorn-apple), and several species of *Hyoscyamus*, including *Hyoscyamus muticus* (Egyptian henbane), both of which contain the alkaloids hyoscyamine, hyoscyne, and atropine.

Henbane is mentioned as a medicine in an Oxyrhynchus papyrus (in Greek) of the first century A.D.⁵

Another plant containing poison that until recently was cultivated in Egypt, is the opium poppy (*Papaver somniferum*), from the ripe capsules of which opium is obtained. This opium yields several alkaloids, the principal of which is morphine. Although the opium poppy is very common in North Africa, it is not known at what period it was introduced into Egypt. Opium, however, was known anciently, and is referred to as a medicine in the Oxyrhynchus papyrus already mentioned, and poppy seeds are named in two papyri of the third century B.C.⁶

Another poisonous plant, black hellebore (*Rhizoma hellebori nigri*), is also mentioned as a medicine in the same Oxyrhynchus papyrus. This plant contains two crystalline glucosides, both of which are powerful poisons. No mention of this plant growing in Egypt can be traced.

¹ III, 15.

² (a) *Ann. Serv.* 5 (1904), 105-9 and Pl. vii (1); (b) private communication.

³ *Royal Tombs*, II, 34-5.

⁴ W. B. Emery, *The Tomb of Hemaka*, 14, 45-8.

⁵ A. S. Hunt, *The Oxyrhynchus Papyri*, VIII, No. 1088, p. 113.

⁶ C. C. Edgar, *Zenon Papyri in the University of Michigan Collection*, 1931, No. 26 (257 B.C.) and No. 46 (251 B.C.).

THE CURRENCY OF EGYPT UNDER THE PTOLEMIES

By J. G. MILNE

BEFORE the conquest of Egypt by Alexander the Great, there was nothing that could be described as a native coinage in circulation in the country: certain metals, usually gold or copper, were traded in exchange both for local and for foreign business, but they were treated as commodities and were not given standards of value: they passed by weight at the market price. Silver is more rarely mentioned in the records of business transactions: it was not obtained from local sources, and, though a substantial amount must have been imported—the inscriptions of Osorkon I show that he had given at least 560,000 pounds of silver, mainly manufactured, to the temples in the first four years of his reign—its use seems to have been confined to articles of luxury or ornament. It is true that much of this silver came from Greek lands in the form of coin, but the reason for this is that to the Greeks a coin was virtually an ingot, and an order for silver bullion would most naturally be met by the dispatch of coins to the required weight. The destiny of Greek silver coins in Egypt is clear from the condition of the hoards—about a score in number before the Greek conquest—that have been recorded;¹ they are typically miscellaneous collections from different districts and of different standards, sometimes mixed up with scrap metal, and often hacked to test their composition in such a way as to obscure what was the most essential point in a coin for the purposes of a Greek trader, the badge of the issuing authority. It would have been a complicated affair for an exchange agent or banker to evaluate such a collection in terms of specie: treated as bullion, they simply had to be weighed out. In two or three cases their destiny is even clearer, as the process of melting and remaking the metal had been started before the hoards were concealed, and half-melted coins or lumps from crucibles are mixed up with the coins.² It may be taken as certain that these coins, so far as the Egyptian merchants were concerned, were regarded solely as bullion. It might have been expected that, after the Persian conquest of Egypt, the Persian coinage of gold darics and silver sigloi would have been made legal currency in the country; but there is no evidence that they were so used. Two instances are recorded of the occurrence of darics in hoards,³ but these are comparatively late, and with the darics there were gold coins of Philip II of Macedon; while there is only one case in which sigloi were found in a hoard,⁴ and then in association with a mixed lot of Greek silver. Sigloi do not occur casually on Egyptian sites, as practically all kinds of currency of later periods do, and it seems fair to conclude that they did not form an official part of the media for the transaction of business in Egypt. Herodotus, it may be said, regards Aryandes as having struck silver coins when he was satrap of Egypt;⁵ but, whatever value may be placed on the story, it does not suggest that the coins were meant for local use, and we need not suppose that they were.

An approximation to coinage may be found in some pieces of gold stamped on both faces with hieroglyphic signs, the reading of which is 'good Gold': these are of adjusted weight, and might be regarded as belonging to the same class as the early Greek coins of pale gold

¹ The hoards of Greek coins have been collected and indexed by S. P. Noe, *Bibliography of Greek Coin-hoards* (2nd edn., New York, 1937).

² *E.g.* Noe, 143 (Benha el-'Asl) and 144 (Beni Hasan).

³ Noe, 322 and 420.

⁴ Noe, 888.

⁵ Herodotus iv, 166.

or silver, but for the fact that they bear no sort of clue to the authority under which they were issued, and so lack the guarantee which was indispensable to the Greek idea of a coin. Obviously under these circumstances they could not have a face value, and it is most probable that they are ingots of gold made up after the convenient Greek pattern in handy lumps: a Greek might have regarded them as staters, but certainly not as *nomismata*.¹

The only coins which can be definitely accepted as struck in Egypt before the time of Alexander belong to the middle of the fourth century, and are copies of Athenian types of the preceding century. In all probability these were produced to be used for the pay of Greek mercenaries, who were employed by the native rebels against the Persian rule, and would naturally want to be paid in Greek money: an Athenian general, Chabrias, had been sent over, and might have taken with him some old dies from the Athenian mint as part of his equipment. Two specimens of such Athenian tetradrachm dies have been found in Egypt, in one case associated with a quantity of old coins;² and another hoard was composed of defaced Phoenician coins, scrap silver, and melted metal, together with new Athenian coins of these old types, presumably just produced on the spot.³ But these copies of Greek coins would only have a currency value to the mercenaries, and the types would have carried no meaning outside the camps of the insurgent party. The same may be said of a solitary gold coin, showing like them Athenian types, though not from regular Athenian dies, which has the name of Tachos, the leader of the rebellion:⁴ dies for gold would not be procurable from Athens, so he had some made with the familiar types for his mercenaries.

When Alexander conquered Egypt, therefore, it is fairly certain that the mass of the inhabitants had no acquaintance with coinage in the Greek sense—the idea that a piece of metal could have a definite purchasing power assigned to it, apart from its metal content and the local market prices, was quite outside their experience. Moreover, the system of coinage to which they were introduced was complicated by the fact that it was on a bimetallic basis, and the ratio of metal values in Egypt had never been the same as in Europe. Egypt, like all the rest of the Empire of Alexander, was to be Hellenized, and the Hellenic ideal of a universal Empire postulated a common currency of one standard for all provinces. Alexander had adopted the Athenian standard, which was based on silver, with gold at a fixed ratio of 10:1, and bronze as a subsidiary token currency; but under the native kings the ratio of gold to silver had been only 2:1.⁵ It may be doubted whether the Alexandrine system would ever have taken root in Egypt, even if the Empire had held together.

In the first instance a mint was set up in Egypt, presumably at Alexandria, and there was an issue of tetradrachms of the normal Alexandrine types:⁶ it is not certain whether any lower denominations were struck at the same time. These tetradrachms were not of course intended for purely local circulation: they would be current throughout the Empire, and equally the issues of other mints would be current in Egypt. So they are found in hoards outside the country, and a large proportion of the Alexandrine tetradrachms that have come from Egypt are of external mints. The Egyptian would not need to trouble about the mint-marks on the coins: they would all be classed together as silver of Alexander, and the ἀργύριον Ἀλεξανδρείον mentioned in an Elephantine papyrus of 311–10 B.C.⁷ would doubtless be of this kind. But a change began to be manifest, even before the death of the boy Alexander put an end to all pretence of unity in the provinces: the silver was still struck in the name of Alexander, though with new types—on the obverse a head of Alexander the Great in an

¹ G. F. Hill in *Num. Chron.*, 1926, 132.

² J. N. Svoronos in *Corolla Numismatica*, 285; G. F. Hill in *Num. Chron.*, 1922, 14.

³ *JEA* 19, 119.

⁴ G. F. Hill in *Num. Chron.*, 1926, 130.

⁵ *JEA* 15, 150.

⁶ E. T. Newell, *Alexander hoards: Demanhur* (New York, 1923), 144–7.

⁷ P. Eleph., 1.

elephant-skin cap, on the reverse a figure of Athene—and the tetradrachms were kept on the Alexandrine standard; but the smaller coins, the drachmas and half-drachmas, were of reduced weight, approximating to the Asiatic standard commonly known as Rhodian.¹ The reason for this change was doubtless that the larger coins would be required as much for external trade as for internal, while the smaller were for local circulation: so the tetradrachms conformed to the standard of the Empire, but the drachmas could conveniently be assimilated to Egyptian values of metal.

It is not clear at what date precisely the next change was made in the standard of the silver: it may have been after the death of Alexander IV, or when Ptolemy took the title of king in 306, or at some intermediate date. The issue of tetradrachms with the name of Alexander and the types described above continued, but the weight was reduced to the Phoenician standard.² This meant that the Alexandrine ideal of a common standard for the Greek world had been definitely abandoned: there was no longer a single authority for the determination of the circulating value of coins, and each of the Successors could fix it as he wished. For the purposes of external trade which involved payments in silver Phoenicia was far the most important part of the dominions of Ptolemy: Egypt imported silver, but did not export it; but the Phoenician merchants would require a supply of silver staters, and therefore Ptolemy adjusted his coinage to their valuation. As will be seen, it was this principle which governed the standard of the Ptolemaic silver for the next century.

This drop in the weight of the silver stater was accompanied by a corresponding drop in the gold: hitherto gold staters and double staters of the Alexandrine standard had been coined in Egypt, the stater being approximately of the weight of two Alexandrine drachmas; and Ptolemy reduced his stater to the weight of two 'Phoenician' drachmas. But the change in the silver standard had been due in part at any rate to the higher value of silver as against gold in Egypt, and for internal purposes it was a mistake to bring down the gold to correspond with the silver. So the next issue of gold was of a different character: the weight of the unit was approximately that of the double stater of Alexander, which would pass outside Egypt on the basis of a weight equivalent to four drachmas, while it was approximately five times the weight of the Egyptian silver drachma: as all Greek gold coinage at this period seems to have been intended to serve merely as an expression of silver for convenience in paying large sums, weight against weight at the local ratio of values, it was obviously desirable to secure the acceptance of a coin by making it of a weight that could be related to alternative standards used in the areas to which it was likely to be sent. This principle governed the issues of gold in Egypt till the middle of the reign of Philadelphus.

There is very little evidence of the use of bronze coins in Egypt during the earlier years of Greek rule; it may be surmised that the classes of the population who would have had most occasion to use it, the peasantry and artisans, had not become familiar with the new idea of coinage, and so low values were not issued in any quantity. The first plentiful bronze issues were after the assumption of the royal title by Ptolemy in 306: these are of the ordinary Greek module, with nothing much more than an inch in diameter, and probably served as tokens for fractions of the drachma: there is no sure basis on which to estimate their denominations, but if a comparison with Syrian coinage can be accepted, the chief denomination may have been a half-drachma.

During the reign of Ptolemy Soter, and for the first part of that of Philadelphus, the official Egyptian currency continued on this basis, which was practically that of Alexander

¹ J. N. Svoronos, *τὰ νομίσματα τῶν Πτολεμαίων*, ii, pp. 7 ff., series iv. 2. (The head of Alexander had appeared with the old reverse types earlier, but no change in weight is associated with this.)

² Svoronos, pp. 18 ff., group 1, series i.

with a reduced silver unit. But it is noticeable that a substantial proportion of the silver tetradrachms of this period are punch-marked or scratched with signs, which is evidence that they were not accepted in trade at the value put on them by the issuing authority. Such marking is found on several series of Greek coins, and in every case it can be shown to be due to the original guarantee of value having ceased to be effective; for instance, the coins of Aegina were freely punch-marked after the reduction of Aegina by Athens, and so were the Persian sigloi after the fall of the Persian Empire.¹ It would appear that the Egyptian merchants took the Ptolemaic silver, not at its nominal value, but as bullion, which at Egyptian rates would be much higher, and marked the coins to signify the fact: it was probably illegal, but the government could not have enforced the acceptance of their coins at an artificial rate without causing a considerable dislocation of trade, and so acquiesced in the practice.

The situation was however obviously unsatisfactory, especially in view of the possession of the greater part of Phoenicia by the Ptolemies: the coinage which was not suited to Egyptian requirements was quite suitable for the Phoenicians; and, so far as silver was concerned, the Phoenician merchants were more important than the Egyptian, for the reasons already stated. About 270 the whole system seems to have been revised, and separate treatment accorded to Phoenicia and to Egypt. There is a plentiful coinage of silver, which belongs to the reigns of Philadelphus, Euergetes, and Philopator, and consists almost entirely of tetradrachms: it is on the Phoenician standard, and the majority of the coins can be assigned by their mint-marks to the mints of Tyre, Sidon, Ptolemais Ake, Joppa, and Gaza; these are normally dated by regnal years.² Coins generally similar to these, but without mint-marks, are also found, and these have been regarded as the issues of the mint of Alexandria.³ But it should be observed that the coins of the mints of Phoenicia have on the reverse the legend ΠΤΟΛΕΜΑΙΟΥ ΣΩΤΗΡΟΣ, not ΠΤΟΛΕΜΑΙΟΥ ΒΑΣΙΛΕΩΣ as on the earlier coins of Soter and Philadelphus and the later ones of the second and first centuries: this distinctive formula may have been adopted for use in these mints from a desire to consult the feelings of the Phoenicians: the omission of the title ΒΑΣΙΛΕΩΣ would avoid emphasis on the foreign overlordship. In the next century a somewhat similar idea may be traced in the coinage of the Seleucid kings at their Phoenician mints: this was on the Phoenician standard, instead of the Alexandrine which was used at Antioch and other Seleucid mints, and so clearly intended for Phoenician trade; and on it the laudatory titles, which were inscribed on the Antiochene issues, do not appear. As the coins of the series under consideration which have no mint-marks bear the same legend as those with the mint-marks of Phoenicia, it is fair to assume that, even if they were struck at Alexandria, they were designed primarily for circulation in Phoenicia. So far as Egypt was concerned, they were on much the same economic footing as foreign coins, and this renders their treatment, or maltreatment, by punching more understandable.

The most important item in the revision of the system for the purposes of Egyptian local circulation was the introduction of an entirely new series of bronze coins,⁴ which were evidently intended to contain an amount of metal bearing some relation to their face values, so as to remove them out of the category of mere tokens. The largest of them are of a size and weight for which there is no parallel to be found in the issues of Greece or Asia Minor: they average about six times the weight of the chief bronze coin of Soter, and if, as is not improbable, they were issued as drachmas, while the earlier coin may have been a half-

¹ *Num. Chron.*, 1931, 177.

² Svoronos, pp. 78 ff., group 8, 1, series ii; 2, ii; 3, ii; 4, i; 5, i: p. 150, group 7: pp. 197 ff.

³ Svoronos, p. 61, group 2: p. 156, group 4: p. 178, group 2.

⁴ Svoronos, pp. 64 ff., group 3.

drachma, the increase in weight was threefold. Such an increase cannot be explained as a raising of the standard: there are a few instances in Greek coinage of the standard of bronze being raised, though the reverse process is much more common; but no raising by more than about twenty-five per cent. is known. The only possible explanation is that the government decided to initiate an independent coinage on a bronze standard, which was not to be subject to the fluctuations of prices of silver: in other terms it may be said that they forsook the Alexandrine silver standard, and dissociated their coinage from the Greek system.

The results of this change are evident almost at once, both in the hoards and in the papyri: in the middle of the third century the typical Egyptian hoard consists not of silver tetradrachms, as was the case about 300, but of bronze of the two largest sizes, which may be taken to be drachmas and half-drachmas; and payments of substantial sums in bronze appear in the papyri. The fact that the Ptolemaic bronze of this period had a real metal value also appears from its export in considerable quantities to foreign countries: the coins of this series have been found all round the Mediterranean, and even as far afield as Britain, and in Italy they were occasionally restruck for the local bronze coinage. Technically it would seem that both silver and bronze were legal tender to any amount in Egypt, and no adjustment should have been needed as between the two for the reckoning of payments: but the fact that silver was undervalued as currency would naturally tend to drive it out of circulation: no one would want to give a silver tetradrachm in payment for a debt of that amount, if he knew that he could get more than four drachmas for it in the silver market.

Gold ceased to play an important part in the Egyptian currency after the reign of Philadelphus: this may have been to some extent due to the exhaustion of the Persian reserve which had been thrown on the market by Alexander, and the consequent recovery of gold values, which would make it better from an economical point of view for the kings of Egypt to export their gold than to use it for local circulation; but in any case internal trade in Egypt would not call for a large supply of coins of high value. The only gold coins struck in Egypt after about 270 are differentiated from the regular silver by the choice of obverse types: the Egyptian silver tetradrachm from first to last continued to bear the head of Ptolemy Soter, with only one brief exception,¹ resembling in this consistency the great Greek commercial coinages; but the gold of the later kings, and a series of silver double staters, had portraits of the reigning king or his queen, alongside of which ran a series with commemorative portraits of Arsinoë II.² The former series ended in the reign of Epiphanes, the latter went on till that of Euergetes II. These coins of exceptional types and exceptional size were probably intended quite as much to serve as medals as to be used for ordinary circulation; and this supposition is borne out by the absence of any record of their having been found in hoards.

Till the end of the third century, then, there was a dual currency in Egypt: the mints of Phoenicia continued to issue coin for the Ptolemies so long as they remained in the possession of Egypt, the last known coin of the series being dated in year 4 of Epiphanes. But that the silver had ceased to be current at its nominal value is shown by an entry in an account, probably of the end of the third century, in which a man pays 16 dr. 5½ obols for a silver stater, which would be either of Alexandrine or Phoenician standard:³ in the former case the silver drachma was worth a little more than four Egyptian drachmas, in the latter somewhat more. This agrees adequately with the rate of exchange known for the first century B.C., which gave an Attic drachma or a Roman denarius for a Ptolemaic tetradrachm. So it was natural that for purposes of trading convenience some kind of adjustment should be made: in certain cases, mainly official payments where large sums of money were

¹ Svoronos, nos. 1123-4, 1136.

² The series begins with Svoronos, p. 64.

³ UPZ, 149, l. 32.

likely to be involved, regulations were issued for taking bronze at a discount, to compensate for the trouble involved in handling it, in others it was taken at par. But as the bronze was exported at a metal value, and the silver was mainly used for foreign trade, the ratio of metals had to be related to external values as well as internal; and, though there are no definite equations recorded in the third century, the terms of certain documents suggest that the conversion of silver drachmas into bronze and vice versa was becoming a recognized practice.¹

The situation was altered by the loss of the Phoenician possessions of Egypt at the turn of the century: there was no longer the need to supply the merchants of Tyre and Sidon with silver coinage, but Cyprus still remained in the hands of the Ptolemies, and did not use the heavy Egyptian bronze as its normal currency. So almost simultaneously with the last issues of Ptolemaic coins from a Phoenician mint, there appeared a new series of tetradrachms at the Cypriote mints of Paphos, Salamis, and Citium.² These continue the same types, but go back to the old legend of ΠΤΟΛΕΜΑΙΟΥ ΒΑΣΙΛΕΩΣ, which suggests that they were struck with a view to circulation in Egypt rather than in the outlying possessions; and they actually did circulate in Egypt much more freely than the Phoenician issues, occurring in considerable numbers in hoards as well as sporadically. It is noticeable that they are not punch-marked like their predecessors, which shows that they were taken at their face value in Egyptian trade: also, while the weight of the coins was approximately the same as before, they were of inferior metal: analysis shows a debasement which steadily increased, till at the end there was only about 25 per cent. of silver in them. This can clearly be connected with the local valuation of silver at the end of the third century mentioned above: if silver was worth four times as much in Egypt as in Greece, the Egyptian drachma should only contain one quarter of the silver in the Greek. Of course this meant that the currency of the debased Ptolemaic silver was practically confined to Egypt; no one outside would look at it at its face value, nor was it attractive as metal. So, while the third-century coins are found in Greece and Asia Minor, the second and first-century tetradrachms hardly ever occur there.

But the debasement of the silver involved a revision of the rates of exchange for the bronze; the two had been related to suit the foreign market, and when outside support forsook the debased silver tetradrachm, the bronze drachma lost ground in sympathy; and its collapse was the more rapid because it had no recognized equivalent in the ordinary Greek schemes of currency. Early in the second century the bronze drachma and its fractions ceased to be struck on the standard introduced under Philadelphus, and a fresh set of bronze coins was issued, which must have been regarded as unrelated to the earlier series, since they are not found associated with them in hoards to any extent: large hoards of the third-century bronze are common, and likewise of the later, but it is rare to come upon even one or two stray examples of the third-century coins in a hoard of the second century. The new model of bronze continued to be struck with little variation in standard till the end of the Ptolemaic dynasty; and the valuation put upon the coins can be deduced from the denominations which appear on the last issues of the series in the reign of Cleopatra VII. The two common bronze coins of this reign are marked respectively Π and Μ,³ which Regling has shown to represent 80 and 40 bronze drachmas,⁴ and it is the more probable that this valuation can be carried back to the beginning of the series, as the sums recorded as paid at this period in papyri postulate the existence of some currency in which the drachma was of very light weight: it is common to find statements of the payment of many talents in bronze money, which would have been an impossible burden in the third-century bronze with its

¹ *E.g.* P. Mich., 173.

² The series begins with Svoronos, p. 217, group 5, 2.

³ Svoronos, p. 311, Nos. 1871 and 1872.

⁴ *Z. f. Numism.*, 1901, 115.

drachma weighing about a quarter of a pound, but was comparatively easy when the bronze talent was represented by seventy-five pieces of eighty drachmas weighing perhaps five pounds in all.

The exact date of the official change-over cannot be settled at present. The new silver coinage began in the second year of Epiphanes, so far as known coins show, but it does not follow that the alteration in the bronze issues was contemporaneous with this: it is quite probable that it was effected somewhat later, when the results of the depreciation of the silver were felt in trade. But it seems to be clear from the evidence of P. Mich. 182 that the change was operating before 182 B.C.; in this papyrus there is a record of a loan of 44T. 4800dr. in bronze, though the penalty for non-fulfilment of the contract is expressed in silver of the old coinage. Whether the payment of the fine would have been made in this old coinage, if a default had occurred, may be doubted: but as the depreciated silver was legally of the same value as the good silver, the terms of the contract would have been satisfied by payment in the new tetradrachms. As a matter of fact, the old third-century tetradrachms lingered on in circulation, and are found mixed up with their debased successors in hoards of the second century and even later: there is no complete break at this point in the silver currency, as there is in the bronze. As the Ptolemaic coinage was from first to last on a nominally silver standard, even when it was expressed in bronze, the purchasing power of the standard coin, the tetradrachm, was not affected by its debasement, any more than the purchasing power of the English silver coinage has been affected by its debasement in 1920. But after the bronze drachma lost its intrinsic relation to the silver and became a mere token, it collapsed at the first crisis and was no more than a term of account.

The natural result of this was that for business purposes a ratio had to be fixed as between the silver and the bronze coins; and from about 160 B.C. it is the normal feature in accounts to convert silver drachmas into bronze or vice versa. The rates vary considerably, but are seldom above 500:1 or below 400:1, and the average works out at nearly 440:1. This indicates that the rate of conversion, like exchange rates to-day, was a matter for settlement in the money market: it is not clear whether the government made any attempt in the second century to control the movements, but if they did it seems to have had as little effect as similar attempts by governments have now. Thirty years ago the rate of the piastre to the pound Turkish at Smyrna, nominally 100:1, varied in commercial quotations from 108:1 to 182:1. In the last years of the dynasty Cleopatra, as we have seen, appears to have tried to stabilize the ratio by marking her coins as of eighty and forty bronze drachmas, which suggests a ratio of 480:1; at this figure the coin of eighty bronze drachmas would be an obol of the silver standard. This agrees approximately with the statement of Festus¹ that the Alexandrian talent was of twelve denarii; as the silver content of the denarius was about the same as that of the Alexandrian tetradrachm, this gives a ratio of 500:1. It is possible that in the second century the government intended the bronze to be taken at a similar rate, but as the coins have no marks of value nothing certain can be said: the commonest pieces, which form the bulk of the hoards of the second and first centuries,² are of a size comparable with that of the eighty drachma coins of Cleopatra.

The evidence of coins found in Egypt shows that there was more joint circulation of silver and bronze in the second and first centuries than in the latter part of the third, and this accords with the evidence of papyri—not so much the official records as the stray entries in private papers. Thus in the middle of the second century we find a man at Tebtunis collecting four drachmas silver—*i.e.* a tetradrachm—and five hundred drachmas bronze on every

¹ Festus, p. 359 (Müller).

² Svoronos, Nos. 1224 and 1384, and 1424.

thirty arourae; and at the same place a complaint of the theft of six hundred drachmas of coined silver and seven talents of bronze.¹ Fortunately the difference between the silver and the bronze drachma is so great that there is little risk of confusion when we have to decide which is meant in a statement of prices or payments: but the variations in the exchange rates must be taken into consideration.

¹ P. Tebt. 739 and 743.

SIR ROBERT MOND, LL.D., F.R.S.

1867–1938

By the death of Sir Robert Mond, F.R.S., on October 22, our Society has lost a munificent President, and Egyptology a devoted student. Born on September 9, 1867, at Farnworth, near Widnes, Lancashire, he was the eldest son of Dr. Ludwig Mond, F.R.S., who, with the Right Honourable Sir John Brunner, P.C., founded the famous firm of Brunner, Mond & Co. He was educated at Cheltenham College; from there he went to Peterhouse, Cambridge, and afterwards to the Zürich Polytechnicum, and Edinburgh and Glasgow Universities. In the last-named University he was private assistant to Sir William Thomson (Lord Kelvin). Early in his career he assisted his father in the discovery of new carbonals, and throughout his lifetime was engaged in pure and applied chemistry. His contributions to chemical journals were many and various. In an appreciation of his scientific work contributed to *Nature* (Nov. 12, 1938) Professor Charles S. Gibson, F.R.S., writes: 'It is difficult to give an adequate account of Robert Mond's scientific and industrial interests. His scientific greatness lay not so much in what he himself discovered or achieved but in what he did to make it possible for those to achieve who were less fortunately placed. Especially after his father's death, he regarded his wealth and position as a trust to be used in the advancement of knowledge and appreciation of beauty, and through that of international peace and fellowship, and he worked incessantly to achieve this ideal.' Among the scientific institutions that benefited by his munificence, the chief was probably the Royal Institution. He served for many years as the Honorary Secretary of the Davy-Faraday Research Laboratory Committee; for a period was President of the Faraday Society, and in 1931 gave the Spiers Memorial Lecture on Faraday. A few years ago he was elected President of the French Society of Chemical Industry, and last year he was mainly instrumental in founding the Society for the Study of Alchemy and Early Chemistry, being its first President, and writing the first article ('On the Study of Alchemy') in its journal *Ambix*.

By profession a chemist, it was to Egyptian Archaeology, among other subjects, that he turned for recreation. It was my privilege to meet him first at his father's house in 1896, and four or five years later, when on a visit to Egypt, he came to me at Luxor and expressed the wish to collaborate in the work that I was then carrying out on a very small scale in the Theban Necropolis. In 1902, on my relinquishing explorations in consequence of other duties, Mond took over the concession that I then held from the Egyptian Government. Early in January 1903 he began work on his own, his first task being the clearance of the tombs of Kēnamūn and Sennūfer at Shēkh 'Abd el-Ḳurnah. In February of that year Mond, Robb de Peyster Tytus, and the present writer helped Howard Carter, then Inspector-General of the Service des Antiquités for Upper Egypt, to clear the tomb of Tuthmosis IV and pack for transport to the Cairo Museum the antiquities found in it. For the next two winters Mond devoted himself to clearing inscribed tombs at Thebes, his annual Reports being printed in the *Annales du Service des Antiquités* (5, 97–104; 6, 65–96). Among other tombs he discovered that of Userhēt (No. 51) which was later published by N. de G. Davies in the Tytus Memorial Series. At the close of 1905 Mond's first wife died tragically at Luxor, and he then gave up personally supervising his excavations, but Howard Carter and Arthur Weigall, the successive Inspectors of Antiquities in Upper Egypt, continued the clearance of

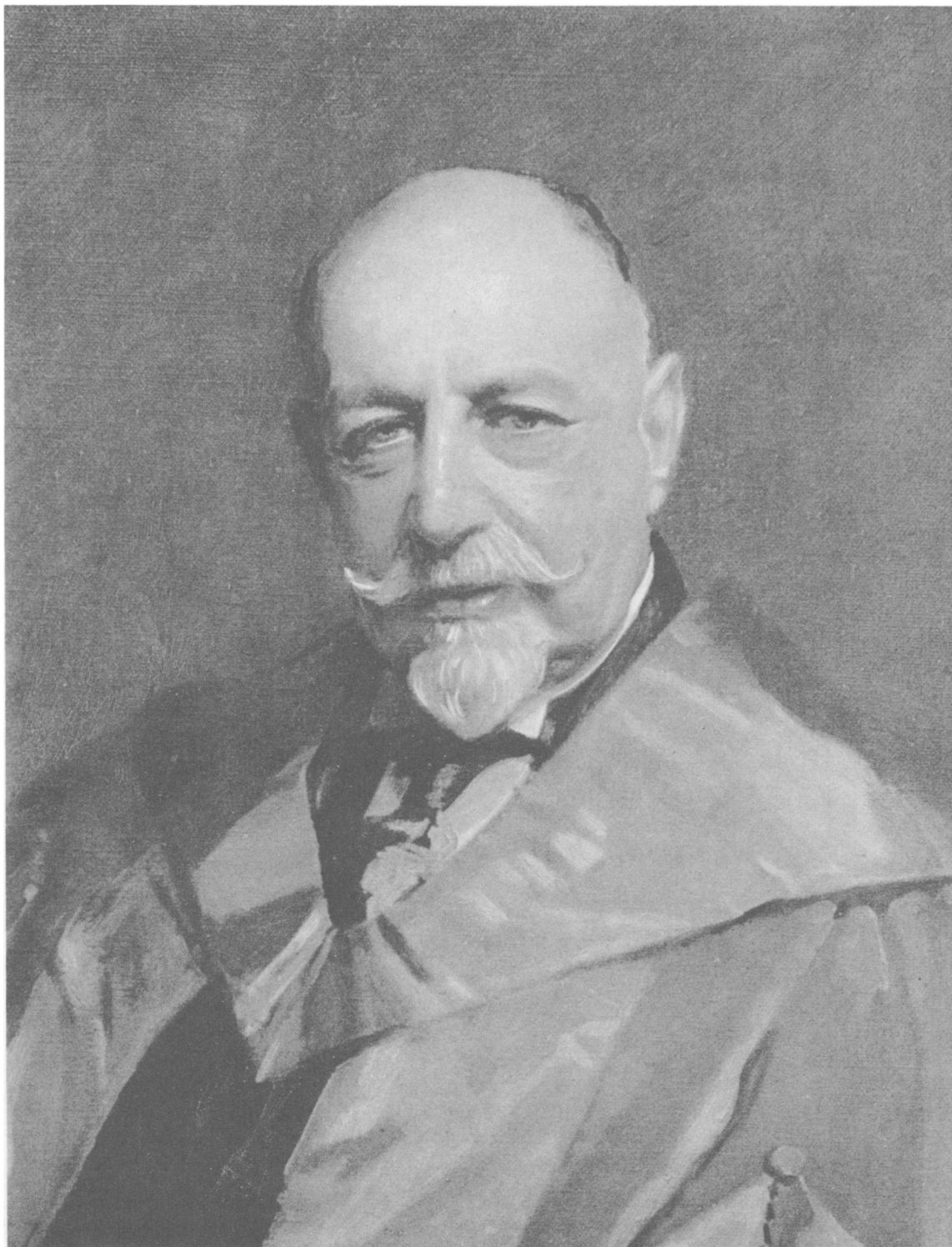

SIR ROBERT MOND, LL.D., F.R.S.
From the painting by Frank O. Salisbury.

the Theban tombs with the financial aid of Mond and others. In 1906 he joined the Committee of the Egypt Exploration Fund, and in 1909 the Committee of the Liverpool University Institute of Archaeology, and was one of the chief supporters of Professor John Garstang's explorations at Meroë in the Sudan and in Asia Minor during the years 1910–1913. In 1909 he sent out from England, at his own expense, Mr. Jelf, an Oxford graduate, to assist Weigall in the work at Thebes. In 1913 was published the *Topographical Catalogue of the Private Tombs of Thebes* by Gardiner and Weigall with the assistance of Robert Mond, and this is a record of what had, up to then, been accomplished at Thebes. In the introduction to this book, Gardiner wrote that it was due 'in large part to the personal endeavours and enlightened liberality of Mr. Robert Mond that the Theban Necropolis is now, on the whole, well protected and in a satisfactory condition'. In a lecture which Mond delivered before the Royal Institution in May 1914 he told his audience that the restoration and preservation of the Theban Tombs had been one of his 'day-dreams' for many years and that he had worked out a well-considered and continuous scheme to achieve this end. 'This object took shape', he said, 'when the opportunity arose which enabled me to secure, after many consultations with the most competent Egyptologists, and especially with Dr. Alan Gardiner, the services of Mr. Ernest Mackay, for many years the chief assistant of Professor Flinders Petrie,' and he announced that Mackay 'will now devote his whole time to the systematic inspection, excavation, restoration, and preservation of these chapels'. Some record of Mackay's work was printed in this *Journal* (3, 125, 219; 4, 74–85). In the spring of 1916 Mond generously lent Mackay to assist N. de G. Davies in building up whole walls from fragments and restoring the tomb of Puyemrē^c to something of its old architectural form. In the summer of 1916 Mackay was called away on war service and work at Thebes had to be abandoned.

It was not until the winter of 1923 that Mond again began explorations at Thebes. Mackay being engaged elsewhere, Mr. Yeivin was employed temporarily to superintend the excavations, and Mr. Walter Emery, a student under the late Professor Peet at the University of Liverpool, was sent out to Egypt. The following year Emery took charge of Mond's work which was now being carried out in association with, and under the aegis of, the Liverpool Institute of Archaeology. His first task was the clearance of the famous tomb of Raemose, the vizier of Amenophis III and Akhenaten. This took three years to complete, and the publication of the scenes and inscriptions in it has recently been entrusted to the skilled hands of Norman de Garis Davies. Mond's, Emery's, and Yeivin's Reports for the years 1923 to 1926 are printed in the *Annals of Archaeology and Anthropology* (13, pp. 3 ff.; 14, pp. 14 ff.).

In the winter of 1925 Mond was growing restless and thinking of transferring his activities to some place outside Thebes. Early in 1926 he and Emery prospected for a new site at Armant and applied, in the name of the Liverpool University Institute of Archaeology, for a concession covering about fifty square miles at the back of Armant. On this concession being granted by the Egyptian Government, excavations were at once begun there by Mond's assistants Emery and A. R. Callender, and the burial ground of the Buchis bulls was soon discovered. Mond now cleared a motor road, ten miles long, from Thebes to Armant, to enable him to visit Emery two or three times a week to inspect the work and record progress. The Preliminary Report on these excavations is printed in the *Annals of Archaeology and Anthropology* 16, pp. 3–12 with Pls. 1–xx.

In 1929 Robert Mond was elected President of the Egypt Exploration Society, and the Armant concession was then transferred to our Society. Dr. Frankfort was sent out with a large staff, Mond bearing the whole cost of the expedition. On being appointed Field-Director of the Irāq Expedition of the Oriental Institute of the University of Chicago,

Frankfort resigned his post with the E.E.S. and Emery having been engaged by the Egyptian Government to carry out the Archaeological Survey of Nubia, Mr. F. W. Green of the Fitzwilliam Museum, Cambridge, undertook to superintend the Armant excavations for a season. Then Mr. Oliver Myers was appointed Director and he has conducted the explorations ever since. Three volumes on *The Bucheum* by Sir Robert Mond and Oliver Myers were issued to the E.E.S. subscribers in 1934 and two on *The Cemeteries of Armant* last year. These volumes show how wide were Mond's interests, for he enlisted the help of no less than sixty-nine scholars and scientific workers to write for these five volumes.

Sir Robert did not confine his archaeological work to the Nile Valley alone. He served as Treasurer of the British School of Archaeology in Jerusalem and of the Palestine Exploration Fund: for the former he instituted a Robert Mond studentship. The cost of Miss Garrod's excavations at Athlit was defrayed by him, and the same lady's work, with others, in the Shukbah Cave near Lydda, was greatly assisted by his generosity. Excavations were also carried out in Brittany under his supervision. During the last two years Mond has also financed the important work of Dr. Hans Winkler in the Eastern and Libyan Deserts, including that scholar's *Völker und Völkerbewegungen im vorgeschichtlichen Oberägypten im Lichte neuer Felsbilderfunde* and the volume *Rock-drawings of Southern Upper Egypt* issued by the E.E.S. a few days before Sir Robert's death.

Sir Robert possessed a collection of antiquities at his apartment in Cavendish Square, but it was his invariable habit to give the best pieces he bought to museums, rather than keep them himself. He was the first to contribute on a munificent scale toward the purchase by London University of the Petrie Collection of Egyptian antiquities.

Among his numerous distinctions were those of Hon. LL.D. conferred upon him by the Universities of Liverpool and Toronto. He was Honorary Trustee of the Royal Ontario Museum, Toronto, the Director, Mr. Currelly, being an old personal friend whom he first met in Egypt. In 1932 he received the honour of knighthood. Last year he was elected F.R.S., which he regarded as the greatest honour a man could receive. He was a Commander of the Legion of Honour and an Officer of the Order of Leopold.

A kinder heart or a more generous mind than his, it would be difficult to imagine. His benefactions in countless directions were great. Archaeology owes him a deep debt of gratitude, and it is to be hoped that it will be possible to continue and complete all the work he initiated. To Lady Mond and his daughters we express our deepest sympathy for the loss they have sustained.

Although Sir Robert lived during his later years mostly in Brittany, where his ashes have been interred, he loved his native country England, and at the Memorial Service held at the West London Synagogue on November 2nd, Rupert Brooke's sonnet was read:

If I should die, think only this of me:
 That there's some corner of a foreign field
 That is for ever England. There shall be
 In that rich earth a richer dust concealed;
 A dust whom England bore, shaped, made aware,
 Gave once, her flowers to love, her ways to roam,
 A body of England's, breathing English air,
 Washed by the rivers, blest by suns of home. . . .

PERCY E. NEWBERRY.

ALAN WYNN SHORTER

1905–1938

ALAN WYNN, the only child of Wilfred Wynn Shorter and Mary Shorter (*née* Mary Adams), was born at 14 Grosvenor Gardens, London, N.W. 5, on June 8, 1905. When he was only two and a half years old he began to suffer from serious bone trouble, and was obliged to wear irons on his legs for nine years and hobble about as best he could with rigid knee-joints. Despite this great disability he attended a kindergarten from the age of five, and then, on attaining his ninth year, went to Sunbury House School, in Willesden Lane, London, N.W. 2, where, thanks to the care and devotion of the Headmaster, Mr. Ernest Dove, he improved greatly in health and made rapid progress in his education. That he was able, however, to go to school at all he owed entirely to his mother's unremitting watchfulness and skilled nursing. When he was twelve years old he entered St. Paul's School, where he was placed on the Science side. But after passing the London Matriculation he informed his parents that he had long desired to have a classical education. Accordingly, with the approval of the High Master, the late Dr. Hillard, who fully sympathized with this ambition, he was moved over to the Classical side. To begin with he was placed not in a form but 'in Hall', where he studied intensively under the able direction of Mr. Pantin, to whom many generations of Paulines feel themselves deeply indebted. At the end of two years Shorter had made such progress in Latin and Greek that, with the additional aid of some self-acquired knowledge of Egyptology, he gained a Classical exhibition at The Queen's College, Oxford.

He went up to the University in October 1924, and promptly won the College prize for Collections. In 1926 he obtained a Second Class in Classical Honour Moderations, and in 1928 a Second Class in the Final Honour School of Oriental Studies, his subjects being Egyptian and Coptic. It was a great disappointment to his friends as well as to himself that he missed a First Class in 'Finals'. This mishap was undoubtedly due to the fact that he had been overworking and was not in a good state of health during the last two terms before the examination.

After coming down from Oxford he joined the Egypt Exploration Society's expedition to Armant and assisted in the clearing and recording of the Bucheum; he also took part in that Society's excavations at El-'Amarnah during the latter part of the same season. Though he enjoyed and made full use of his time in Egypt it soon became obvious to himself and his colleagues that his real interest lay rather on the philological than on the archaeological side of Egyptology. On his return to England, therefore, he gladly accepted the post that was offered him in the Department of Egyptian and Assyrian Antiquities in the British Museum, where he continued to work, mainly on MSS. of the Book of the Dead, till his fatal illness overtook him.

In 1931 Shorter married Joan, the elder daughter of the much-loved Headmaster of his preparatory school. There are four children by this marriage, three boys and a girl.

In 1933 he was received into the Roman Catholic Church, a change-over which, so he told the writer, opened out a new life for him. In May 1938 he was stricken down with pneumonia, and, despite his own courageous fight for life and the devoted nursing of his wife and mother, died on the 31st of that month after three weeks' illness.

Shorter was the author of three pleasing little books, written with a view to increasing the interest of the general public in ancient Egypt. The books in question are *An Introduction to Egyptian Religion*, *Everyday Life in Ancient Egypt*, and *The Egyptian Gods*, published respectively in 1931, 1932, and 1937.

How serious is the loss that English Egyptology has suffered by his premature death the scholarly first volume of his *Catalogue of Egyptian Religious Papyri in the British Museum* (London, 1938) clearly shows, as do also the many articles which he contributed from time to time to this *Journal*, the first of these, *A Possible Late Representation of the God 'Ash* (vol. 11, 78 f.), having been accepted while he was still an undergraduate.

It is a matter of great regret to his colleagues that he has not been spared to bring out the second volume of his *Catalogue* and to publish, as he always hoped to do, an authoritative work on Egyptian religious beliefs and practices during the New Kingdom.

As the writer of this notice remarked in *The Pauline* of July 1938, Shorter possessed great strength of character and could never be persuaded to put expediency before principle. But he could be a charming and highly entertaining companion, and was at all times and in all circumstances a most faithful and sympathetic friend.

A. M. BLACKMAN.

BIBLIOGRAPHY: PHARAONIC EGYPT (1937)

EDITED BY A. M. BLACKMAN

THE work is divided as follows:

- § 1. Archaeology. G. A. WAINWRIGHT.
- § 2. Art and Architecture. N. DE G. DAVIES.
- § 3. Conservation. A. N. DAKIN.
- § 4. Demotic Studies. S. R. K. GLANVILLE.
- § 5. Excavations and Explorations. M. F. L. MACADAM.
- § 6. Foreign Relations. I. E. S. EDWARDS.
- § 7. Geography and Topography. A. M. BLACKMAN.
- § 8. History. R. O. FAULKNER.
- § 9. Law. S. R. K. GLANVILLE.
- § 10. Literature. R. O. FAULKNER.
- § 11. Palaeography. A. M. BLACKMAN.
- § 12. Personal Notices. A. N. DAKIN.
- § 13. Philology. A. M. BLACKMAN.
- § 14. Publications of Texts. M. F. L. MACADAM.
- § 15. Religion and Magic. A. M. BLACKMAN.
- § 16. Science, Mathematics, &c., is unavoidably held over.

For the explanation of abbreviations used in references to periodicals, &c., see the list at the end of this volume.¹

The Editor of this Bibliography would be grateful if scholars would facilitate the work of compilation by kindly sending to him at the Institute of Archaeology, 11 Abercromby Square, Liverpool 7, off-prints of their articles, and, so far as is possible, copies of their books. He also wishes to thank his colleagues who have once more so kindly co-operated with him in this undertaking. He is further deeply grateful to Mr. A. N. Dakin for reading through the MS. before it went to Press, and for making it conform with the usages of the *Journal*, a task that he was unfortunately prevented by illness from undertaking himself.

The date '1937' is omitted in the case of books, periodicals, &c., published in that year.

1. Archaeology

R. ANTHES revs. at length in *OLZ* 40, 218 ff. JUNKER's *Giza II*.

A. J. ARKELL, *The Double Spiral Amulet in Sudan Nn. and Records* 20, 151 ff., collects instances of these from the Sudan and other lands. He supposes it to be derived from the bicornuate symbol on the head of Meskhenit.

¹ Considerations of space have necessitated compression of the text of this Bibliography by abbreviation of many frequently recurring words. It is hoped that the abbreviations will be self-explanatory, but to avoid any possible obscurity a list of all except the most obvious is given here: anc. = ancient, ancien, -s, -ne(s); Antiq. Dept. = Antiquities Department (Service des Antiquités); archaeol. = archaeolog-y, -ical; art(s). = article(s); BM = British Museum; comm., -s. = commentar-y, -ies; Cop. = Coptic; dem. = demotic; doc(s). = document(s); edn. = edition; Eg(n). = Egypt(ian); Ég. = Égypte; ég. = égyptien, -s, -ne(s); ét. = étude(s); fragm(m). = fragment(s); Gk. = Greek; hierogl. = hieroglyph(ic); hist. = histor-y, -ical; illust(s). = illustration(s); inscr(r). = inscription(s); Inst. = Institute; Inst. fr. = Institut français; MFA = Museum of Fine Arts (Boston); M.K. = Middle Kingdom; MMA = Metropolitan Museum of Art (New York); mus. = museum, musée(s); n(n). = note(s); N.K. = New Kingdom; not., -d., -s. = notice, -d, -s; O.K. = Old Kingdom; ostr(r). = ostrac-on, -a; pap., -p. = papyrus, -i; Ptol. = Ptolemaic; publ., -d., -n(s), -s. = publi-sh, -shed, -cation(s), -shes; ref(s). = reference(s); rev., -d., -r., -s. = review, -ed, -er, -s; Rom. = Roman; transcr(r). = transcription(s); transl., -d., -n(s), -s. = transl-ate, -ed, -ion(s), -es.—EDITOR, *JEA*.

H. ASSELBERGHS in *Ex Oriente Lux*, 4, 176 ff. and pls., has a series of arts. on *Excavations, Further Publns.*, and *The Sailor who climbs the Rigging*.

C. BACHATLY in *Bull. Inst. d'Ég.* 19, 117 ff. and pls., publs. some Capsian implements from north of the Fayyūm.

A. BAYOUMI, *Survivances ég.* in *Bull. Soc. Roy. Géogr. d'Ég.*, 279 ff., publs. 4 extracts from medieval Arab authors which clearly originate in Pharaonic days. Two give methods of discovering whether people are sterile or not; another is a receipt for destroying superfluous hair; the fourth concerns the vast serpent which tries to devour the sun at its rising and setting.

E. BILLE-DE MOT calls attention in *Chron. d'Ég.* 12, 219 ff., to a piece of a faience rhyton of Cretan shape. It is now in the Brussels Mus., and came from the MacGregor Sale. *Id.*, in *Bull. des Mus. Roy. d'Art et d'Hist.* 9, 81 ff., a well-illustrated art. on the Tell el-'Amarnah objects in the Brussels Mus.

F. W. v. BISSING, *Seltene Formen frühzeitlicher Schminkpaletten* in *ZÄS* 73, 56 ff., describes 3 palettes, one a misunderstood pelican, one adorned with two bulls' heads, and another in the form of a wasp (?); *id.*, *Die blauäugige Königin Teje* in *ZÄS* 73, 123 f., points out that the lady in question is not Tiya of Dyn. 18 but Titi of Dyn. 21, and that the colour of the eyes in the painting is most questionable; *id.*, *OLZ* 40, 201 ff., revs. at length REISNER, *The Devel. of the Egn. Tomb down to the Accession of Cheops*; *id.*, *Bull. Soc. arch. d'Alex.*, 211 ff., *Sul tipo dei SISTRI trovati nel Tevere*, is an important study of Graeco-Roman sistra originating in the finding of 6 in the Tiber near the Iseum; *Ann. R. Sc. Pisa* 4, 1, 67 ff., *Oberteil einer Isisfigur aus Faience*, and *Statuette des Museo del Palazzo dei Conservatori*.

F. BISSON DE LA ROQUE in *Chron. d'Ég.* 12, 21 ff., gives further particulars and illustrs. of the 12th-Dyn. treasure of Et-Tūd.

BLACKMAN, *The Value of Egyptology in the Modern World* is revd. shortly by HERMANN in *OLZ* 40, 418.

L. BORCHARDT, *Zur Gesch. d. Pyramiden* in *ZÄS* 73, 106 ff., returns to his series of studies, the last of which appeared in vol. 32. This time his subject is the Step Pyramid, which he finds was built on a site of tombs that were already robbed. The great well in the pyramid is the great vertical pit of the original maṣṭabah. The great southern tomb, which is so mysterious, he concludes to be older than Djoser and to have been utilized under him; *Altäg. Mattenhütten u. Mattenhütten bei den Tuaregs* in *ZÄS* 73, 118 f., makes a convincing comparison between the archaic pictures of shrines and the huts of the modern Tuareg; *Denkmäler d. Alten Reiches (ausser den Statuen)*, I, is another vol. of the *CCG*. Kha-bau-seker's collar-necklace is once more called that of the high priest of Memphis, but the wearer does not bear that title, and it is only exceptionally that the insignia is worn by the high priest.

C. BOREUX in *Bull. des Musées de France*, 39 ff., publs. a large bronze Sakhmet, and 66 f., a beautiful little head in painted limestone of one of Akhenaten's little daughters; in *Rev. de l'art anc. et mod.* 41, 211 ff., he discusses an early M.-K. ivory statuette. The man holds back his kilt in a manner peculiar to Middle Eg. B. supposes this gesture to be a form of etiquette. *Id.*, in *Chron. d'Ég.* 12, 77 ff. (reprint from the *Journal des Débats*, Oct. 26, 1936), recording the centenary of the setting up of the obelisk in the Place de la Concorde at Paris. The account is a reminder of the immensity of the undertaking in setting up an obelisk and of the excitement caused, whether in the 16th cent. in Rome when Fontana removed the obelisk from the Circus Maximus to the Piazza del Popolo, or in the 19th cent. in Paris, London, or New York. No doubt the original rejoicings in Eg. had been equally great, and the occasions even more important.

K. BOSSE, *Der menschliche Figur in der Rundplastik der äg. Spätzeit von der XXII. bis zur XXX. Dyn.*, 1936, collects and describes a number of these statues. The places of origin, dates, materials, details, &c., are described with a view to discovering the sequence of developments.

L. G. BOYD and W. C. BOYD, *Les Groupes sanguins chez les anciens Ég.* in *Chron. d'Ég.* 12, 41 ff., point out the astonishing fact that they have been able to carry out blood tests on Egn. mummies and assign them to their blood groups. All kinds of information interesting for the history of mankind are adumbrated by the new science of blood tests. In Eg. it shows that the quality of the inhabitants' blood has scarcely varied since predyn. days.

P. BRANDT Collection (Amsterdam); Ptol. mummy-masks from this collection are publ. in *Ex Oriente Lux*, 4, 272, and pl.

H. BRUNNER, *Die Anlagen der äg. Felsgräber bis zum Mittl. Reich*, is revd. shortly by Mlle WERBROUCK in *Chron. d'Ég.* 12, 210 f., and at great length by v. BISSING, *OLZ* 40, 499 ff.

G. BRUNS, *Der Obelisk u. seine Basis auf dem Hippodrom zu Konstantinopel*, is revd. by CASSON in *JRS* 27, 289 f. He treats almost entirely of the problems of the classical reliefs on the base.

L(UDLOW) B(ULL), *Egn. Antiquities from the Pier Collection* in *Bull. of the Associates of Fine Arts at Yale*

Univ. 7 (1936), 30 ff. and figs. This collection was sold by auction at the Anderson Galleries, New York, in March 1936.

A. W. VAN BUREN, *Obeliskos* in *PW*, xvii, 2, 1705 ff., gives a short account of the use of obelisks in Eg. and details about the various obelisks brought to Italy and Constantinople by the Emperors.

CAPART notes the following works in *Chron. d'Ég.* 12: 67, O. KOENIGSBERGER, *Die Konstruktion der äg. Tür*; 67 ff., FIRTH and QUIBELL, *The Step Pyramid* and LAUER, *La Pyramide à degrés*; 194 f., ERMAN's book for children, *Die Welt am Nil*, with a long extract on pp. 195-8; 208 f., PILLET's art. in *Bull. Inst. fr.* 36, *L'Extraction du granit en Ég. à l'époque pharaonique*; 209, REISNER, *The Dog which was honored by the King of Upper and Lower Ég.* in *Bull. MFA* 34, calling attention to his own publ. long ago of a dog's coffin; 212 f., WINLOCK's *Egn. Statues and Statuettes*; 213 f., VAN WIJNGAARDEN's *Eenige opmerkingen over de zoogenaamde beeldengroep van Mert-tefs*, pointing out that this has been usurped by a certain Khenou who was attached to her funerary temple; 217 ff., WINLOCK, *An Egn. Flower Bowl*, suggesting that seeds may have been sown in the bowl, so that the cow walked in verdure rather than among lotus flowers as W. thinks; 222 f., T. G. ALLEN, *Egn. Stelae in the Field Mus. of Nat. Hist.*; 227, H. RYDH, *Huru man levde i Faraosland*, a Swedish book for children. In *Brooklyn Mus. Quarterly*, 21 ff., C. describes 2 painted coffins of Dyn. 21 and later.

G. CATON-THOMPSON, E. W. GARDNER, and S. A. HUZAYYIN in *Bull. Inst. d'Ég.* 19, 243 ff. and pls., examine the new theory of the hist. of the Fayyūm Lake propounded by the Geol. Survey of Eg. They give more evidence, gathered in 1937, to support their own view. The Survey believes that HERODOTUS was right in thinking that the flood water of the Nile entered Lake Moeris and flowed back into the Nile Valley when the inundation subsided, thus making the Lake into a vast reservoir.

J. ČERNÝ, *Deux noms de poisson du nouvel empire* in *Bull. Inst. fr.* 37, 35 ff., publs. some ostr. with drawings of the fish called to-day *kurkār*, or, in the north, *shāl*, which latter proves to be its anc. name.

P. F. CLINTON, *The Connoisseur*, 88 ff., figures a variety of not very good shawabti and some scarabs and contributes a fairly good general art. on them.

J. COONEY, *Brooklyn Mus. Quarterly*, 189 ff., basing his remarks on an O.-K. torso received by the Mus. speaks of Egn. sculpture and the unsympathetic treatment it has received until recently.

P. B. COTT, *Worcester (U.S.A.) Art Mus. Annual* 1, 17 f., figures and describes an uninscribed life-size female torso of O.-K. workmanship, which has been recently acquired by the Mus. It comes from 'excavations in the vicinity of the Great Pyramid of Gizeh'.

E. DARTEVELLE-PUISSANT, *Notes conchyliologiques africaines* in *Chron. d'Ég.* 12, 50 ff., names a quantity of shells found in Eg. and gives a short bibliography of the subject.

D. DUNHAM, *Bull. MFA* 35, 11 ff., describes and figures a number of objects from Tell el-'Amarnah, among others a brick from the building whence came the Tell el-'Amarnah Letters. It is stamped 'Records-Office of Pharaoh (to whom be) Life, Prosperity, Health'; 50 ff. compares the Egn. bird-trap to a 15th-cent. Italian one and reconstructs it. It is found to work efficiently; 70 ff., a splendid small head in green slate of the Saite period. It is in the naturalistic style so well known from the statue of Mentu-em-hēt; 73 f., records objects received in exchange from the MMA and gives a photo. of a hawk's head from the temenos wall of Senusret I's pyramid at Lisht. *Id.*, *Naga-ed-Dér Stelae of the First Interm. Period*, publs. in full detail 87 of these stelae, gives an attempt at classifying them into 4 groups according to date, but is not able to discover any development or degeneration in the workmanship (rev. by CAPART in *Chron. d'Ég.* 12, 214 ff.). In *JAOS* 56, 173 ff. and 2 pls., D. publs. a number of squeezes presented to Boston in 1878 and 1886, several of which were taken from scenes which have now disappeared. D. records the progress of the Egn. Dept. of the Boston Mus., the accessions, publns., lectures, &c., in the *The Sixty-First Annual Report for the Year 1936*, MFA, and contributes the Egn. section to the Buffalo Fine Arts Academy's publ. *Master Bronzes*. It consists of 4 pp. of text, a bibliography, and figs. 42-61, each with its description. In *The Connoisseur*, p. 39, D. figures the statue of Amūn and devotes half a page to its description.

R. DUSSAUD in *Syria* 17, 93 f., revs. FÉVRIER, *Les Origines de la marine phénicienne*, and points out differences between the Egn. and Phoenician ships. The Egn. ships were essentially river-boats adapted for sea-going. He also points out that the earliest intercourse between Eg. and Syria was by ship.

E. S. EATON, *Bull. MFA* 35, 54 f., explains a curious picture of the O.K. It proves to be a jumping-game, still played by boys in Trans-Jordania. See also under Z. SAAD below.

I. E. S. EDWARDS, *A Toilet Scene on a Funerary Stela of the M. K.* in *JEA* 23, 165 and pl., shows a lady before her table of offerings, but holding a mirror and also a towel with which she is wiping her face.

R. ENGELBACH, *Ann. Serv.* 37, 1 f., *Statuette of Yi from Elephantine*, publs. a 12th-Dyn. figure, the hands

of which are turned up as if to receive offerings and have the words 'offerings' and 'food' inscribed on them.

R. J. FORBES, *Bitumen and Petroleum in Antiquity*, is revd. by P. COREMANS in *Chron. d'Ég.* 12, 225 f. He gives a useful bibliography, and like others comes to the conclusion that it could only be from the Ptol. period that bituminous products might have been used in Eg., and even then only very rarely.

J. S. F. GARNOT, *Le Lion dans l'art ég.*, *Bull. Inst. fr.* 37, 75 ff., studies the characteristics in the modelling of lion figs. during the different periods.

H. GAUTHIER publs. *Un curieux monument des dynasties boubastites à Héracléopolis Magna* in *Ann. Serv.* 37, 16 ff. and pl. The title of Amūn suggests that the sculpture, like another found at Heracleopolis, was not original there but was brought from the 17th Nome of the Delta.

P. GILBERT, in *Chron. d'Ég.* 12, 27 f., thinks one of the objects from the royal tombs at Ur shows Egn. influence; *Le Thème de groupement des Grâces avant les Grecs* in *L'Antiquité Classique* (Brussels) 5, 373 ff. carries back the idea of sculpturing the Graces dancing round the stone to 12th-Dyn. sculptures in Eg. He passes in review other sculptures of a similar nature from other lands.

G. GOYON, *Ann. Serv.* 37, 81 ff., reports the fitting in of various fragmm., found by the French at Tanis, of the well-known and badly damaged statue of Senusret I which was brought to Cairo by BARSANTI in 1905.

Anc. Egn. Sculpture Lent by C. S. Gulbenkian Esq. (with 22 pls.) is a description of the objects on loan to the BM. The chief of these, of course, is the splendid obsidian head of Amenemhēt III which was originally in the MacGregor Collection. In *Chron. d'Ég.* 12, 221 f., CAPART revs. the work, giving valuable information as to previous publns. of many of the objects. Accounts of the exhibit also appear in *The Museums Journal* 36, 489, and in *Arch. f. Or.* 12, 81 ff., *OLZ* 40, 678 ff.

W. C. HAYES, *Glazed Tiles from a Palace of Ramesses II at Qantir (MMA Papers, 3)*. A classification and study of the glazed tiles which have come recently in quantities from Qantir, 15 or 16 miles S. of Tanis (Ṣan el-Ḥagar). The site proves to have been an important palace-city from Sethos I to Ramesses X, that is to say, for a period of 200 years or so. It is with good reason that the author asks whether this was not really the Delta residence of the Ramessides rather than Tanis whose claims have been so warmly advocated. The palaces were largely lined and floored with multi-coloured faience tiles, thus antedating the well-known Assyrian custom by some 600 years. A short résumé is given by E. BILLE-DE MOT in *Chron. d'Ég.* 12, 219 f. HAYES publs. in *Bull. MMA* 32, 157 f. a writing-palette of the chief steward Amenhotpe and lists up a number of other objects of A. scattered in other museums.

A. HERMANN, *Die Katze im Fenster über der Tür* in *ZÄS* 73, 68 ff., studies some cases where a domestic cat takes the place of the better-known sphinx in the window-lattices. He asks whether it was because this was a favourite place for the cats to sun themselves in the winter and cool themselves in the summer; *OLZ* 40, 209 ff. a long and detailed rev. by H. of FIRTH-QUIBELL and LAUER's books on the Step Pyramid.

U. HÖLSCHER, *The Excavation of Medinet Habu, I*, is revd. by v. BISSING in *Arch. f. Or.* 11, 255 ff.

W. HÖLSCHER, *Libyer u. Äg.: Beiträge zur Ethnologie u. Gesch. libyscher Völkerschaften nach d. altäg. Quellen (Ägyptol. Forschungen, Heft 4, Glückstadt)*. A detailed discussion of the various Libyans, their land, dress, history, personal appearance, as known to us from Egn. sources. Like so many others the author quotes LUCAN, *Pharsalia* x, 129, as mentioning the fair hair of some Libyans. But surely, taken in its natural sense the passage contrasts the 'Libyan', i.e. African, hair of the one group of slaves with the fair hair of another unnamed group.

Ill. Ldn. News, Jan. 2, objects from a 1st-Dyn. cemetery in the Avenue of Sphinxes, Ṣaḳḳārah; restoration of the funerary temple of Amenhotpe son of Ḥapu at Thebes; Feb. 13, mummy and objects from the tomb of Hat-nufer, mother of Senmut; Feb. 27, plan of the tomb of Sabu of Dyn. I at Ṣaḳḳārah including the unique schist bowl; Mar. 6, O.-K. alabasters and a Rom. bath from Edfu; June 12, the discovery of a park for sacred ibises and their vast necropolis at Hermopolis West; July 3, reproductions of Mrs. BRUNTON's paintings of Cleopatra, the queen of king Teti, and a pectoral of Tut'ankhamūn; July 31, the first Hittite sculpture from Cilicia; Oct. 9, decorated pottery with Cretan connexions from Tell Atchana near Antioch; Oct. 16, objects from Megiddo including some Egn. ones; Oct. 23, Egyptianizing ivories and other objects from Megiddo; Nov. 27, Egn. and Egyptianizing objects from Lachish; Dec. 11, Romano-Egn. hair-nets and caps in the Field Mus., Chicago.

G. JÉQUIER writes in the *Gazette de Lausanne*, Jan. 24, exposing once more the fallacies and absurdities of pyramidology. It seems that this peculiarly Anglo-Saxon and German aberration has been gaining ground recently in the French world. The art. is reprinted in *Chron. d'Ég.* 12, 147 ff.

P. JOUQUET in *C.-R. Ac. Inscr. B.-L.*, 1936, 239 ff., discusses the Treasure from Et-Ṭūd.

L. KEIMER in *Bull. Inst. d'Ég.* 19, 147 ff., makes some preliminary remarks on the study of the pig in Anc. Eg. The native figures and drawings only show the wild boar, while the Graeco-Rom. terracottas show the Indian pig (*Sus vittatus*) which fattens easily, and was apparently introduced into Eg. only in classical times.

A. LANSING, *Bull. MMA* 32, 285 f., figures and describes various O.-K. objects received by the MMA from Boston in exchange. They include an unfinished statuette of Menkaurē exhibiting the methods of the sculptor.

H. LARSEN, *On Baking in Eg. during the M. K.* in *Acta Archaeologica* (Copenhagen) 1936, pp. 51-7. A careful study of a baking-oven, bread moulds, and the method of employment, based on finds at Abu Ghālib in the W. Delta.

A. P. LAURIE, *The Fayūm Portraits Painted in Wax, Technical Studies in the Field of the Fine Arts* 6, 17 f., adds some remarks to Miss Dow's in vol. 5. His students painted quite easily with melted wax, though naturally it required a technique of its own.

J. LEIBOVITCH in *Bull. Inst. d'Ég.* 19, 81 ff., publs. two stelae of the goddess Kadesh; the one at Moscow from the Golenischeff Collection, the other in Cairo from Ehnāsyah. Both are in a very poor condition.

I. LEXOVA, *Anc. Egn. Dances*, is shortly revd. by A. HERMANN in *OLZ* 40, 22 f.

G. LOUKIANOFF, *Ann. Serv.* 37, 219 ff., publs. a number of objects from the tomb of Pediamenōpet which are now scattered in many museums.

A. LUCAS in *JEA* 23, 27 ff., publs. *Notes on Myrrh and Stacte*. He here recurs to a subject on which there is infinite confusion in modern as well as anc. times, discussing such things as resins, myrrh, frankincense, and other incense materials. In considering the anc. *stacte* he arrives at conclusions which are different from STEUER's and which seem more probable.

G. DE MANTEYER, *Les Origines de l'Europe, II: le site de l'Ég.* An amazing outpouring of learning to do with an original universal alphabet, the original homeland of the Aryans, pyramidology, &c.

H. DE MORANT, *Chron. d'Ég.* 12, 29 ff., 162, has a well documented art. on *Le Chat dans l'art ég.*; also writes in *La Nature* (Paris), 385 ff., *La Verrerie dans l'anc. Ég.* with figs. CAPART points out in *Chron. d'Ég.* 12, 214, that the Menkheperre mentioned is not Tuthmosis III but the king of Dyn. 21.

At long last the 2nd fasc. of NEWBERRY's *Funerary Statuettes and Model Sarcophagi* has appeared in the *CCG*. The pls. are still to come.

I. NOSHY, *The Arts in Ptol. Egypt*, gives an excellent account of the situation as between Greeks and Egns. and its result on the architecture and sculpture of the time.

J. M. PAUL, *Le Massage à travers les âges in Aesculape* 27 shows on p. 15 an O.-K. sculpture from Şakkārah of masseurs at work on the fingers and toes of their patients. For Egyptologists the sculpture will be better seen in WRZESINSKI, *Atlas*, III, Pl. 23.

J. PERCIVAL contributes a most valuable illustrated art. *Cereals of Anc. Eg. and Mesopotamia to Nature*, Aug. 15, 1936. The corn discovered in the tombs of Anc. Eg. is invariably Emmer wheat (*Triticum dicoccum*) and barley. Two kinds of barley were cultivated in Anc. Eg., Bere barley (*Hordeum vulgare*) and Six-rowed barley (*H. hexastichon*). No other form of wheat than Emmer was cultivated in Eg. down to the end of the Dynastic period. This being so, we must assume that the two words *bd-t* and *sw-t* refer to some technical difference in the one type of Emmer. Very little ancient grain has been rescued from Mesopotamia, but what has been is Emmer and barley as in Eg. Small Emmer comes from Arpachiyah, but a large Rivet wheat from Jemdet Nasr. This is *Triticum turgidum*, a superior type of Emmer, such as is grown in Abyssinia to-day.

PETRIE publs. another vol. of his Catalogue of the Collection at University College. The two small catalogues of *The Funeral Furniture of Eg.* and of *Stone and Metal Vases* are bound in 1 vol. *The Funeral Furniture* is not illustrated by pls. but is a discussion of the various classes of objects with descriptions of many and references to the publns. *Stone and Metal Vases* carries on the tradition of the other vols., with many pls. arranged in type series and full discussion of the development of each and much other information. Dr. M. MURRAY revs. P.'s *Shabtis* in *Man*, 69 f., and notes that this is at present the only work dealing with so numerous a class of Egn. antiquities. NEWBERRY's vols. in *CCG* are now in process of appearing. P. has a number of short arts. in *Syro-Egypt* 1, 9 ff. *New Tools in Archaeology* refers to the results obtainable by drawing frequency curves of the occurrence of objects and the study of racial characteristics in skulls; 13 f. revs. REISNER's *Devel. of the Egn. Tomb*, pointing out the entirely hypothetical nature of the superstructures R. gives to the Royal Tombs of Abydos.

A. PIANKOFF in *Bull. Inst. fr.* 37, 29 ff., studies a curious statuette of Bes of the Ptol. age, and discusses the various types of this god.

CH. PICARD, *Un Tombeau royal à Saqqarah* in *J. Sav.*, 241 ff., is an appreciation of the Step-Pyramid complex taken almost entirely from the work of LAUER, FIRTH, and QUIBELL.

M. PIEPER calls attention in *OLZ* 40, 472, to HORWITZ's art. on Egn. and Assyrian siege-engines publ. in *Zeits. für hist. Waffen- und Kostümkunde*, 1932, and, 354 ff., revs. ERMAN's *Die Welt am Nil*.

E. S. G. ROBINSON, *A Gold Comb- or Pin-head from Eg.* in *JHS* 57, 79, publs. a strange group in classical style of the early 3rd cent. B.C. It represents Demeter, Persephone, and Harpocrates, the latter in an unusual form.

G. ROEDER, *Äg. Bronzewerke*, publs. 44 pls. and many figs. of the numerous bronzes in the Pelizaeus-Mus., Hildesheim. He does not confine himself to the statuettes, tools, and implements, but also studies the methods of manufacture, and then attempts to distinguish the craftsmanship of Lower, Middle, and Upper Eg. He had begun this type of inquiry in his *Statuen äg. Königinnen*. In a work of the size of the present there must be shortcomings. For instance the animal, Pl. 34, g and § 239, is inscribed to Horus of Letopolis. Yet R. calls it an ichneumon, though it is not like one, but is like a shrewmouse, which we know was sacred at that city. Figs. i, k, l, though called ichneumons, are also shrewmice. Fig. h is, however, an ichneumon, and a very good one. It is quite unlike the others. v. BISSING points out a number of defects in his long rev., *OLZ* 40, 727 ff. *Chron. d'Ég.* 12, 63, R. makes an addition to his art. *Vier Statuen* in *Ann. Inst. phil. hist. or.* 3 (1935).

A. ROWE, *Catalogue of Egn. Scarabs, Scaraboids, Seals, and Amulets in the Palestine Archaeol. Mus.*, Cairo, 1936, is much more than its title indicates. It gives a detailed list of Egn. contacts with Syria from Predyn. days to the time of Alexander. The scarabs are fully illustrated, grouped, classified, and tabulated. Finally a graph is given to indicate the extent to which the various periods are represented. The most common naturally turn out to be the Hyksos period and that of Dyns. 18 and 19. At the end of the book various other Egn. objects from Palestine are discussed, notably an axe from the River Adonis dating from Khufu or Sahurê. Indices of every sort complete this admirable vol.

Z. SAAD, *Ann. Serv.* 37, 212 ff., adds to EATON's information in *Bull. MFA* that the O.-K. high-jump is played in modern Eg. as well as in Transjordan. In Eg. it is called *khazza lawizza*.

Sales: Mar. 2, a collection was sold by Christie; Nov. 9-12, E. GUILHOV's collection of rings was sold by Sotheby; Nov. 23-5 the collection of W. M. MENSING was sold at Amsterdam by Mensing & Fils (Frederik Müller & Cie).

A. SCHARFF in *OLZ* 40, 288 ff., revs. at some length CATON-THOMPSON and GARDNER's *The Desert Fayum*. He would like to bring the date of the older neolithic culture down from the authors' 5000 B.C. to 4000 B.C., which seems to leave an extremely short time for many happenings. He also says that MENGHIN and BITTEL have since fixed the Qaṣr es-Ṣaḡha to the O.K., whereas the authors of the book under rev. did not care to decide between the O.K. and M.K. Together with MENGHIN, S. assists KOEPP in his hist. of archaeol. in the Near East. This sect. occupies pp. 61-6 of W. OTTO's *Handbuch der Archäol.*

W. SCHUBART in *Gnomon*, 218 f., revs. VON BISSING, *Äg. Kultbilder d. Ptolomaier- u. Römerzeit*, making some useful remarks on the various forms given to such gods as Serapis, Isis, Canopus, and others.

M. S. SHAW in *JMEOS* 21, 23 f., gives a detailed verbal description of a mummy and its coffin now in the Manchester Mus., but unfortunately gives no photos. It is that of a certain divine father of Amūn, Khary, son of Ankh-pa-khred and Merit-Amūn, of Dyn. 19. *Ibid.*, 51 ff., S. gives the essence of W. C. HAYES, *Royal Sarcophagi of the XVIIIth Dynasty*.

A. W. SHORTER in *BM Quart.* 11, 32 f., publs. a head from a hollow-cast bronze fig. of Ramesses II, and a stone fig. of Taurt with a lion's head and mane.

W. S. SMITH, in *JEA* 23, 17 ff. and pls., reconstitutes a good part of Atet's wall from which came the famous Mēdūm geese, collecting the fragmm. from a variety of Museums.

C. V. SILVER, *Egn. Shipping of about 1500 B.C.*, is a transl. and reworking in *The Mariner's Mirror* 22, 430 ff. with pls., figs., and maps, of his book in Danish, *Puntlandets Genopdagelse c. 1500 f. C.* It deals primarily with Punt and the voyage thither under Hatshepsut, but also with Egn. shipping in general.

J. L. STARKEY, in *PEQ*, 228 ff. and pls., reports from Lachish scarabs of Hyksos kings and many of later kings, also a bowl with a hieratic inscr. of the 13th-12th cents. B.C. Another important piece is the dagger which can be definitely dated as not later than 1600 B.C. It bears signs of the Sinaitic script and another sign which occurs in Crete and the Aegean.

G. STEINDORFF in *ZAS* 73, 122 f., publs. a beautiful vase-stand in pierced bronze. The designs are of regular N.-K. type, and the object is now in the Field Mus., Chicago.

R. O. STEUER returns to the study of incense in his *Über das wohlriechende Natron bei d. alten Äg.* This is a much larger work than his original one *Myrrhe u. Stakte.*

J. VANDIER publs. in *Syria* 18, 174 ff. and 2 pls., the Asiatic treasure from Eṭ-Ṭūd dating to the reign of Amenemhēt II.

V. VIKENTIEFF publs. P. BOBROVSKY's *Collection of Antiquities* (Paris) and devotes a long comparative study to the remarkable polytheistic statuette from Antioch. It is a combination of Taurt and Horus the Child.

G. A. WAINWRIGHT, *The Pyramids of Meroë in a Japanese Colour-Print* in *Antiq.*, 229 ff. and 2 pls., shows that CAILLAUD's pls., publ. in Paris in 1823, had reached Japan and had been used by an artist there before 1829. This also witnesses to the interest shown by the Japanese in the outside world even in the days of their strict seclusion; in *JEA* 23, 125 ff., W. revs. in considerable detail CATON-THOMPSON and GARDNER, *The Desert Fayum*; *ibid.*, 127 ff., BORCHARDT, *Einiges zur dritten Bauperiode d. grossen Pyramide bei Gise*; *ibid.*, 129, he mentions B. STEWART's *Hist. and Significance of the Great Pyramid*, though it proves to be only a pyramidological book.

M. WERBROUCK in *Chron. d'Ég.* 12, 211 f., mentions the great publ. of ostr. from Dēr el-Madīnah by VANDIER D'ABBADIE. The first of these vols. concerns the animals and the last the satirical drawings. *Bull. des Mus. roy. d'Art et d'Hist.* 9, 36 ff., W. publs. a number of pieces of sculpture from the Mentuḥotpe temple at Dēr el-Bahari which are now in Brussels.

W. D. VAN WIJNGAARDEN publs. and discusses the group in the Leiden Mus. showing Mertitefs, another woman, and a boy named Khenu, *Oudheidkundige Mededeelingen uit het Rijksmus. van Oudheden te Leiden, Nieuwe Reeks*, 17, 1 ff.; and 9 ff., a study of an O.-K. statuette of a woman grinding corn, with remarks on the extension of the saddle quern. In *Ex Oriente Lux* 4, 261 f. and pl., he publs. a bronze fig. of a bat, and 262 a M.-K. head of black granite.

H. A. WINKLER, *Völker u. Völkerbewegungen im vorgeschichtlichen Oberäg. im Lichte neuer Felsbilderfunde* (Stuttgart), gives some specimens of the rock-engravings, and makes a preliminary division of them into groups, with an attempt to date them in terms of Egn. pre-hist. and hist.

H. E. WINLOCK, *Bull. MMA* 32, 173 ff., describes the reconstituting of a lady's head-dress from the separate pieces. The result is convincing though unique, and gives more a medieval than an Egn. effect; in *MMA 67th Annual Report*, 17 f., W. gives a résumé of the Egn. Dept.'s activities. *Id.*, *The Private Life of the Anc. Egns.* is appreciatively mentioned by SPIEGEL in *OLZ* 40, 93.

W. WRZESINSKI, *Atlas z. altäg. Kulturgesch.*, Teil III, Lief. 1-3, publs. a number of O.-K. scenes. Pl. 1 is unique in showing the artist at his easel which has ratchets for propping the board at the desired angle. Pl. 17 also has a scene which is probably unique. It has already been publ. in DAVIES, *Ptahhetep and Akhetetep*, and shows the farmyard including 1,225 swans. Pls. 25, 26 give the well-known circumcision scenes, and 23, 24 the less well-known ones of massage. Pls. 33-5 include metal-casters, and boat-builders appear on Pl. 36.

2. Art and Architecture

A. GENERAL

H. BRUNNER, *Aeg. Kunst (Die Kunst dem Volke)*, 85; München, 36 pp., 70 figs.). A brief description of the achievements of Egn. art under the conditions imposed forms a useful introduction to a series of excellent photos., so well selected to portray the many sides of the subject as to be of use to others than the general reader.

A. BUGGE contributes a sect. on Eg. (pp. 11-47, 16 figs., 8 pls.) to *Oldtidens Kunst i Europa og Asien (Verdens Kunsthistorie)*, Oslo.

G. CAROTTI, *L'arte dell' antico Egitto* (304 pp., 325 figs., 8 pls., Milan). A posthumous work brought out, perhaps inadvisably, by E. TEA.

CAPART, *Les Limites de l'art ég.* in *Bull. de l'Office Internationale des Insts. d'Arch. et d'Hist. de l'art*, Paris, 3, 34 ff. This important subject is somewhat querulously treated in an exposition of the many cases in which the supposed limitations of Egn. art were surmounted.

W. DEONNA in *Les Limites de l'art ég.* (*ibid.*, 93 ff.) replies to CAPART. Valuable as a brief but lucid estimate by a classicist of the gulf between the art of Eg. and that of Greece after the archaic period had been left behind, setting forth the infinitely greater freedom and promise of Gk. art, but stopping short of an explanation how the Gk. could make the transition from primitive to realistic art which Eg. found impossible, and

the admission that, since the transition is a possible one, Eg. will also provide approaches to what was out of the question for her as a general advance.

Egyptische Kunst en Beschaving in het Rijksmuseum van Oudheden (te Leiden), The Hague, 119 pp., 28 figs. An enlarged and better printed edn. of the 1928 guide to the Egn. collection in Leyden Mus. Some of the additional illu. are much more than just adequate.

W. WRZESINSKI, *Atlas zur altäg. Kulturgesch.*, admirably continued by H. GRAPOW and H. SCHÄFER, has progressed as far as the 3rd issue of Part III. Revd. by DRIOTON in *Rev. arch.*, 293 f.

B. CONTRIBUTIONS OF RESTRICTED SCOPE

A. P. LAURIE, *The Fayum Portraits painted in Wax in Technical Studies in the Field of the Fine Arts* 6, 1, 17 f. A brief claim that painting in wax was a simpler matter than has generally been assumed.

Master Bronzes selected from Museums and Collections in America, Buffalo. A finely illustrated catalogue of an exhibition at Buffalo, N.Y., with an interesting account of methods of casting. An introduction in 5 pp. to the Egn. section (Figs. 42-61) is by D. DUNHAM. Revd. by v. FALKE in *Pantheon*, 210 ff.

I. NOSHY, *The Arts in Ptol. Eg.*, London, 153 pp., 18 pls. This book is welcome both for itself and on account of the nationality of the author, who seems to have made western standards of thoroughness and documentation his own. The title is a little deceptive, however. The book deals with the influence of Greece on Egn. art, or rather with her failure to exert it. In this domain Greece and Eg. remain apart to the end. Revd. by FAIRMAN in *Ann. Arch. Anthr.* 24, 172 ff.

K. PFLÜGER, *The Art of the Third and Fifth Dyns.* in *JEA* 23, 7 ff. A briefly sketched suggestion that 5th-Dyn. art, inspired chiefly from Lower Eg., carries on the imaginative art of the 3rd, and that the art forms of the 4th Dyn., under the influence of Upper Eg., break into this development.

A. SCHARFF, *Egn. Portrait Sculpture* in *Antiq.* 11, 174 ff., 8 pls. The author reduces the attainment of portraiture by Egn. statuary to extremely small proportions, identification being assured by the inscr. The body was an ideal one. The face only came near being a copy at periods when conventions were subject to strain, as at the zenith of the M.K., the El-'Amarnah period, and about 500 B.C.

VANDIER D'ABBADIE, *Catalogue des ostr. figurés de Deir el Médineh*, Fasc. 2 (*Filles. Inst. fr.*, II, 2), 156 pp., pls. 37-92. This second part deals mainly with persons instead of animals. Most of the plates are coloured or tinted by the skilful hand of the authoress. They exhibit the Egn. draughtsman at his ease and following his fancy, and, though divisible into classes, show large variation and individuality.

C. MATERIAL INDIRECTLY PROVIDED

A few books may be cited that contain helpful illustrations.

Anc. Egn. Sculpture lent by C. S. Gulbenkian, Esq. A catalogue of the temporary exhibition at the BM with text by S. SMITH and I. E. S. EDWARDS and 32 admirable photos of this exceptionally select collection. No. 16 should not be dated before Dyn. 19. The famed obsidian head is rightly ascribed to the M.K., as against RANKE. Revd. fully and informatively by E. ZIPPERT in *Arch. f. Or.* 12, 81 ff.; also in *Ann. Arch. Anthr.* 24, 169, and *OLZ* 40, 678 ff.

Catalogue of Egn. and Classical Antiquities from the Collection formed by Frederick Temple, First Marquess of Dufferin and Ava, Christie, London, 8 pp., 3 pls. Representations of a royal statue in limestone (end of Dyn. 18?), a granite Sakhmet (Dyn. 18), and a cedarwood mummy-case (Saite).

H. GRAPOW and H. SCHÄFER, *Eine ungewöhnliche Darstellung der Sonnenbarken* in *ZÄS* 73, 97 ff. A peculiar convention replacing a perspectival view.

In Memoriam L. Earle Roue reproduces a good O.-K. bust in wood from the Rhode Island School of Design.

G. LOUD in *Ill. Ldn. News*, Oct. 27, 707 ff., (fine ivories from Megiddo).

F. B. R., *Tód* (*Filles. Inst. fr.*, 17) shows fine fragmm. of M.-K. sculpture.

C. ROBICHON and A. VARILLE, *En Égypte*. A bright picture-book with exceptional photos., architectural and otherwise. The portico of the temple of Hibis, Khargeh (No. 60), should have been cited as a clever restoration (by M. BARAIZE).

D. REVIEWS OF WORKS PUBLISHED BEFORE 1937

Of F. W. v. BISSING, *Aeg. Kunstgesch.* at length and critically by R. ANTHES in *Phil. Woch.* 57, 603 ff. Also in *OLZ* 40, 20 ff., and in *ZDMG* 91, 515 f.

Of N. M. DAVIES, *Anc. Egn. Paintings*, at length by C. R. WILLIAMS in *Am. Journ. Phil.* 41, 638 ff. Also in *Apollo* 37, 45; *Burlington Mag.*, 99 ff.; *Chron. d'Ég.* 12, 64 ff.; *OLZ* 40, 285 ff.

Of H. RANKE, *The Art of anc. Eg.* in *Burlington Mag.*, 54; *Connoisseur*, 44 f.; *Pantheon*, 33.

Of H. SCHÄFER, *Das altäg. Bildnis*, at some length by W. HÖLSCHER in *OLZ* 40, 697 f.

Of VANDIER D'ABBADIE, *Catalogue des Ostrr. figurés*, Fasc. 1. in *Aeg.* 17, 301.

3. Conservation

H. CHEVRIER, *Rapport sur les travaux de Karnak (1936-1937)*, in *Ann. Serv.* 37, 173 ff., gives an account, with illusts., of the restoration of walls round the Sacred Lake, the consolidation of architraves, a gate and a staircase in the Hypostyle Hall, the strengthening of a lintel in the temple of Khonsu, and other improvements.

In a rev. of G. JÉQUIER, *Le Monument funér. de Pepi II: I, Le tombeau royal (1936)*, A. M. BLACKMAN points to J.'s work on the underground passages and chambers as a valuable lesson in methods; *Ann. Arch. Anthr.* 24, 170 ff.

J.-P. LAUER, *Note sur divers travaux effectués à Saqqarah en 1936 et 1937*, *Ann. Serv.* 37, 103 ff., with pl., describes his work near the pyramid of Wenis, the excavation, reconstruction, and protection of walls and reliefs in several maṣṣabahs; he has also rediscovered blocks from the temple of Wenis (too carefully hidden by BARSANTI in 1901), made arrangements for storing blocks from Djoser's temple, and completed the electric light system in the Serapeum and the maṣṣabah of Ti.

Another art. by LAUER, *Rapport sur les restaurations effectuées en 1936-1937 dans les monuments de Zoser à Saqqarah*, in *Ann. Serv.* 37, 96 ff., describes, with pls., his restoration of the papyrus-columns, the façade of the 'Southern House' and the *serdab* (in which a cast of the original statue has been placed), and his identification of many parts of columns from the entrance to the enclosure.

H. E. WINLOCK, *An Egn. Headdress*, in *Bull. MMA* 32, 173 ff., gives an account of the reconstruction of an elaborate 18th-Dyn. head-dress for a woman, consisting of strings of gold rosettes, originally inlaid with carnelian and glass.

4. Demotic Studies

W. F. EDGERTON, *Medinet Habu Graffiti: Facsimiles*, includes a large number of dem. copies, many of considerable length. Transliterations and translns. of these are promised by E. in a forthcoming vol. Briefly revd. by R. O. FAULKNER, *JEA* 23, 268.

W. ERICHSEN, *Demotische Lesestücke*, I, one of the two outstanding contributions to dem. studies, is revd. by H. GRAPOW in an interesting summary, *Zur Erforschungsgeschichte des Demotischen (OLZ 40, 478 ff.)*.

The other is F. LL. GRIFFITH, *Catalogue of the Dem. Graffiti of the Dodecaschoenus*. This monumental work contains facsimiles (prepared by Mrs. GRIFFITH) and translns. with comms. of 508 graffiti, of which 450 were recorded on the various buildings of Philae. The bulk of these are *proscynemata*—in some cases no more than the name of the visitor is written—many of which were the work of priests or others of the staff of the temple concerned. A few contain biographical detail, and there is interesting material as to the nature of temple gifts and the upkeep of festivals, &c. The graffiti include a small number of legal records, mostly oaths. The most interesting is the long inscr.—the longest dem. graffito known—left by the envoy of king Teqriramane of Meroë to Rome (*i.e.* the Rom. emperor or some representative of his?) in the middle of the 3rd cent. A.D. (Philae 416). The importance of the work, however, lies in its contribution to lexicography and, above all, palaeography. There are 284 pages of indices containing facsimiles (apart from the vol. of facsimiles of the complete texts) of the significant variations of all words, numerals, names, etc., found in the graffiti arranged to show the transition from the most normal to the most unrecognizable orthographies. Many of the graffiti here recorded will soon be illegible owing to the latest heightening of the dam at Aswān. Many had already perished long before this book was printed, and are recorded from squeezes or copies made by copyists from the time of Napoleon's expedition onwards. GRIFFITH had access to all the known material of this kind, and the willingness of his contemporaries, BÉNÉDITE, HESS, SPIEGELBERG, ERMAN, GRAPOW, and ROEDER—to mention the most obvious—in putting unpubl. work at his disposal in order that he might make a standard collection is the highest tribute that could be paid to his scholarship. Revd. by SEIDL in *KVGR* 29, 245 ff.

An alabaster block with incised Gk. inscr. has been identified by O. GUÉRAUD as the upper part of the stela of Moschion, long since preserved in Berlin. The dem. inscr. were publ. by REVILLOUT in *Rev. égyptol.* 2, 272 ff., and formed the basis of E. BOUDIER's *Métrique démotique*. GUÉRAUD discusses the stela

and transls. both the old and the new Gk. poems on it in *La Stèle gréco-démotique de Moschion* (*Bull. Soc. arch. d'Alex.* 31, N.S. 9, 161 ff.).

N. J. REICH, *The Papyrus-Archive in the Philadelphia University Mus. (The Papp. from Dirā' abū 'l-Naga)*, 1 (*Mizraim* 7, 11 ff., pls. 1-10), revises his descriptive list (*Mizraim* 2, 13 ff.) of docs. I-XI of this important dem. archive, and gives photographic reproductions (much reduced in size, but very clear) of docs. III-XI and XIV, all hitherto unpubd.

E. SEIDL's valuable *Demotische Urkundenlehre nach d. frühptolemäischen Texten*, *Münch. Beitr.* 27, and his joint review-art. with B. H. STRICKER of THOMPSON'S *Family Archive from Stut* (*Studien zu Pap. BM. eg.* 10591, *Z. Sav.* 57, 272 ff.) are notd. in the Graeco-Roman Bibliography, § 6 A (v), p. 107, above.

T. C. SKEAT, *The Reigns of the Ptolemies. With Tables for Converting Egn. Dates to the Julian System* (*Mizraim* 6, 7 ff.), besides providing an elaborate ready-reckoner, is an extremely convenient statement of the publ. Gk. and dem. evidence for Ptol. chronology, with valuable nn. on all the controversial points.

B. H. STRICKER, *Études de grammaire ég. (Acta Or.* 16, 81 ff.), shows that *sdm:f* in dem. has always perfect sense and never historic past; and in *Notices sur le pap. dém. 30646 du Musée des Antiquités au Caire* (*ibid.*, 85 ff.) contributes 16 pages of grammatical nn. on *Setne*, with a short reasoned statement of his attitude towards the transcr. of dem.

Sir H. THOMPSON, *Note on t hyr(t) in Boundaries of Ptol. Conveyances of Land* (*JEA* 23, 258) shows that this fem. word has no connexion with the similarly spelt masc. *hyr*, 'street', but (with its variants) is 'the same as the word *hret*, 'food', frequently found in dem., and in Cop. *ꜥꜣꜥ*', and = Gk. *τροφή* (for *τροφεῖον*), 'a feeding-place', with special ref. to the quarters of sacred animals and birds.

5. Excavations and Explorations

A. EGYPT AND THE SUDAN

Sesebi. Excavations begun by the EES uncovered three temples in a single block dating from the 4th year of Amenophis IV, the central temple having a small crypt beneath with reliefs of Amenophis IV and the Queen in the company of various gods. The figures of the King and Queen had been hacked out. See *JEA* 23, 117 and 145 ff.; *Chron. d'Ég.* 12, 190 ff.; *AJSL* 53, 203 and 54, 74; *Nature*, July 10; *Times*, July 5. See also § 15, p. 237 f.

Anibah. The 2nd vol. of the report of the Antiq. Dept. Miss. archéol. de Nubie 1929-34 describes the buildings and temple in the town, the N.-K. cemetery and the tomb of Pennūt. The results of the Ernst v. Sieglin Exped. of 1912 and of the Eckley B. Coxe Jr. Exped. of the Univ. of Pennsylvania of 1910 are also embodied in the report. See G. STEINDORFF, *Aniba*, 2. Band, mit Beiträgen von D. MARCKS, H. SCHLEIF u. W. WOLF, Glückstadt, in 2 parts, text and pls.

Edfu. The excavations of the Inst. fr. together with the Univ. of Warsaw were concerned with rubbish mounds west of the temple of Horus, of which the top levels were of the Rom. town, with houses of the Ptol. period beneath, and with the Egn. necropolis at the bottom. Here 9 untouched tombs were found, of which the oldest was that of Pepy-nefer, governor of Edfu in Dyn. 6. Some fine objects of this date came from the tombs. See *Ill. Ldn. News*, Mar. 6, 403; *Chron. d'Ég.* 12, 185 f.; *Forsch. u. Fortschr.* 13, 273 ff.; *Arch. f. Or.* 12, 94; *Jahrb. d. Arch. Inst. (Archäologischer Anzeiger, Beiblatt)* 52, H. 1-2, 270 ff.

El-Kāb. The exped. of the Fondation Ég. Reine Élisabeth under CAPART reports that the temple was built under Dyn. 18 and had 3 sanctuaries, being successively enlarged down to the time of Nectanebo II. A smaller temple to the W. was dedicated to Thoth. Several statues and bas-reliefs with names of kings from Dyns. 18 to 30 were discovered. See *Chron. d'Ég.* 12, 132 ff.; *Bull. Acad. Roy. Belg. (Classe des Lettres)*, p. 12; *Ann. Serv.* 37, 3 ff.

Gebelen. The Italian Egyptol. Exped. announces the discovery of tombs of Dyns. 1 to 5. See *Chron. d'Ég.* 12, 168, also *Oriente Moderno* 17, 357; *Chicago Daily News*, May 1.

Et-Tūd. For further arts. on the treasure previously reported see *Chron. d'Ég.* 12, 21 ff.; *C.-R. Ac. Inscr. B.-L.*, 1936, 239 ff.; *Syria* 18, 174 ff. This season's excavations of the Louvre have revealed a sacred lake of two basins, with fragmm. of statues and Christian pottery. For further details see *Chron. d'Ég.* 12, 157 ff., 170 f.; *Egn. Gazette*, Apr. 13; *AJSL* 53, 262. A complete report of the excavations of the Inst. fr. for the past few years has appeared, viz. F. B[ISSON DE LA] R[OQUE]: *Tôd (1934 à 1936)*, Cairo.

Armant. The EES under O. H. MYERS has this season continued the excavation of the Ptol. temple, in which well-preserved blocks from earlier structures, ranging in date from Dyn. 11 to 26, were discovered. The investigation of a hillock named Kōm el-'Abd at the edge of the desert was also undertaken. This was

found to be a building of unbaked brick, the bricks bearing the name of Amenophis III. Further undertakings included the excavation of a pan-grave cemetery and of a Cop. monastery, and the further investigation of the 'Saharan' civilization, of which pottery had been found previously. For this purpose a desert exped. under Dr. WINKLER explored the E. desert between Luxor and Armant and brought back many photos. of rock-drawings. It is hoped that further traces of the 'Saharan' people will be found later by a similar exped. into the W. desert. Interesting hierogl. inscr., introducing a new queen and princesses of Dyn. 13, are reported from the road from Armant to Nag' Hammādi. See *Chron. d'Ég.* 12, 171 ff.; *JEA* 23, 117; *Geograph. Journ.* 87, 95 f.; *Arch. f. Or.* 11, 275 f.; *Egn. Gazette*, May 18.

Thebes (Karnak). For a report on work of the Antiq. Dept. in 1935-6 see *Ann. Serv.* 36, 131 ff. For that of 1936-7 see *Ann. Serv.* 37, 173 ff. H. RICKE gives a further account of the small temple of Hatshepsut and Tutmosis III in *Ann. Serv.* 37, 71 ff.

Thebes (Valley of Queens). A short not. of the activities of the Italian Egyptol. Exped. in *Chron. d'Ég.* 12, 180. See also *Oriente Moderno* 17, 357.

Thebes (Kurnat Mur'āi). See *Ann. Serv.* 37, 33, for the report of the finding of the pedestal of a statue of Ramesses II.

Thebes (Kōm el-Hētān). On the discovery of the temple of Amenhotpe, son of Hapu, see further in *Chron. d'Ég.* 12, 174 ff. and 211; *Rev. arch.* 9, 82 f.; *Ill. Ldn. News*, Jan. 2.

Thebes (Dēr el-Madīnah). The reports of the excavations of the Inst. fr. 1933-4 have been publ., viz. B. BRUYÈRE: *Rapport sur les fouilles de Deir el Médīneh* (1933 à 1934), 1e partie: *la nécropole de l'ouest*; 2me partie: *la nécropole de l'est*, Cairo.

Thebes (Shēkh 'Abd el-Kurnah). For a full account of the MMA exped. 1935-6 see *Bull. MMA*, Jan., sect. II. Summary in *Ill. Ldn. News*, Feb. 13, 272; *Scientific American*, Nov., 266 ff.; *New York Times*, Jan. 17; *Life*, Jan. 25; *AJSL* 53, 204.

Thebes (El-Khōkhah). The Antiq. Dept. report the discovery of an inscribed tomb-chamber with 2 inscribed sarcophagi. *Ann. Serv.* 37, 37 f.

El-Mustagiddah. G. BRUNTON's report (*Mostagedda and the Tasian culture* with a chapter by G. M. MORANT, London) explains the findings of the BM exped. in 1928-9 in great detail, with new material for the study of the Badarian and Tasian cultures.

Tell el-'Amarnah. The excavation of the Great Palace was completed by the EES and some buildings of uncertain purpose cleared. Among the objects found are mentioned a relief showing the transport of an obelisk, a complete Mycenaean vase, a Cypriot vase still containing fluid, and some fragmm. of relief and fayence. See *Chron. d'Ég.* 12, 180 f.; *Arch. f. Or.* 11, 276 ff.; *JEA* 23, 118 f.

Tūnah el-Gebel. The Egn. Univ. Exped. announces the discovery of a large Rom. well near the tomb of Petosiris, and of a number of subterranean galleries in which the sacred animals of Thoth were buried. See *Chron. d'Ég.* 12, 185; *Ill. Ldn. News*, June 12, 1088 f.; *AJSL* 54, 73 f.; *Arch. f. Or.* 12, 94 f.

El-Eshmūnēn. The account of the German expedition's excavations in 1935 is publ. in *Mitt. deutsch. Inst. Kairo* 7, 1 ff.

Madīnat Mādi. See *Arch. f. Or.* 11, 402 f., for a further summary of the excavations of the archaeol. exped. of the Royal Univ. of Milan.

Šakkārah. FIRTH and QUIBELL, *Excavations at Saqqara: The Step Pyramid*, 2 vols., Cairo, and LAUER, *Fouilles à Saqqara: La pyramide à degrés*, 2 vols., Cairo, are revd. in *Chron. d'Ég.* 12, 67 ff. The latter is revd. at great length by CH. PICARD in *J. Sav.*, 241 ff. (*Un Tombeau royal de la IIIe Dyn. à Saqqarah*). A further discovery was made by the Antiq. Dept. under W. B. EMERY, that of the tomb of Sabu, an official of Dyn. 1, in which the body was in its original position, unembalmed. See *Chron. d'Ég.* 12, 163; *Ill. Ldn. News*, Feb. 27, 348 f.; *Egn. Gazette*, Feb. 10, Feb. 11, Mar. 1; *Discovery*, March, 88; *Museum News*, Mar. 15, 3; *AJSL* 53, 259 f.; *Arch. f. Or.* 12, 93 f.; *Times*, Apr. 16, Apr. 23; *New York Times*, Apr. 16. Various activities of the Antiq. Dept. in *Ann. Serv.* 37, 103 ff.

Ma'ādi. MENGHIN and AMER, *The Excavations of the Egn. Univ. in the Neolithic site at Maadi, 2nd prelim. report (season 1932)*, Cairo, 1936, is revd. by R. PITTIONI in *Anthropos* 32, 307.

Fustāt. *Ann. Serv.* 37, 58 ff., contains an account of the clearance by the Antiq. Dept. of a rock tomb containing a large number of sarcophagi. Further reports speak of the discovery of a tomb containing an enormous sarcophagus with a normal-sized coffin within. See *Chron. d'Ég.* 12, 183 f.; *Egn. Gazette*, Feb. 17; *AJSL* 53, 257 f.

Abū Ghālīb. A report of the work undertaken by the Egn. Museum in Stockholm appeared in *Nature* 24 (July), 168 f.

Zakāzīk. Twelve large sarcophagi of sacred bulls, all plundered, were found at Kōm Abū Yasīn by the Antiq. Dept. Nearby were small chambers containing mummies of falcons with their eggs beside them in jars. See *AJSL* 55, 213; *Nature*, Dec. 18, 1967. Photos. in *Daily Telegraph and Morning Post*, Dec. 29.

Tanis. For a report on the continued work of the Univ. of Strasbourg Exped. on the Great Temple see *Chron. d'Ég.* 12, 181 ff. Some stelae, statues, &c., were discovered. Further work was done on the large brick building north of the temple of Anta, which was found to contain a number of wells. See also *Kēmi* 5 (1936), 71 ff.; *C.-R. Ac. Inscr. B.-L.*, p. 142; *AJSL* 53, 261 f.

El-Kabbāri. B. HABACHI, *Two Tombs of the Rom. Epoch recently discovered at Gabbari*, in *Bull. Soc. arch. d'Alex.* 31, N.S. 9, 270 ff.

B. OUTSIDE EGYPT

Sinai (Zuwēyid). For an account of work of the Brit. Sch. of Arch. at Anthedon see *Syro-Egypt* 1, 3 ff. Egn. objects are announced from Town C, the Maccabaeian town. See also *Syro-Egypt* 2, 3 ff. and PETRIE, *Anthedon, Sinai* (Brit. Sch. of Arch. and Egn. Research Account publ., 58), London.

Palestine (Tell Duwēr). An Egn. scarab of the 16th-Dyn. king 'A-hetep-Rē^c was found on the surface by the Wellcome Marston Exped. From a triple-chambered tomb of the Hyksos period came a great number of seals and scarabs of the late 18th and early 19th Dyns. and one of Dyn. 13. More scarabs came from adjoining tombs. See *PEQ*, 228 ff. and 178.

C. MISCELLANEOUS

The following are concerned with excavation and/or exploration in Eg. and the Sudan. H. GAUTHIER, *Les Fouilles en Ég. en 1932-1933*, in *Rev. d'égyptol.* 1 (1933, appeared 1937), 289 ff.; M. BRION, *La Résurrection des villes mortes*, Paris; G. CATTAUL, *Chronique d'Ég.*, in *Mercure de France*, Sept. 15, 640 ff.; M. BEKAERT, *À travers l'Ég. et le Soudan*, in *Conférences et Théâtres* (Brussels), 4, 299 ff.; C. R. WILLIAMS, *News Items from Eg., the season of 1936 to 1937 in Eg.*, in *AJA* 41, 629 ff.

6. Foreign Relations

A. EGYPT

F. W. v. BISSING, *Die blauäugige Königin Teje*, *ZÄS* 73, 123 f., points out the error in RECHE's *Rasse u. Heimat der Indogermanen*, 16, where it is stated that 'Egn. sources report of the Mitannian princess Teje, who married the Pharaoh Amenophis III, that she was blue-eyed'. R. was misled, for, as is well known, Teje was the daughter of Yuya and Tjuyu. In the same art. the writer warns against the hasty identification of the Hurrians with the Kharu of the Egn. inscrr.

The same author, in *OLZ* 40, 201 ff., commenting on G. A. REISNER's *Devel. of the Egn. Tomb* (1936), remarks that the Egn. people from the beginning were a mixed race and quotes R.'s view that the predominant components were Libyan and Semitic.

F. BISSON DE LA ROQUE, *Le Trésor de Tôd*, *Chron. d'Ég.* 12, 21 ff., describes briefly some of the objects contained in the Et-Tūd treasure and discusses its purpose, date, and provenance.

A. FAKHRY, *Blocs décorés provenant du Temple de Louxor*, *Ann. Serv.* 37, 39 ff., publ. with line-drawing illu. 16 fragmm. of texts and scenes from a hitherto unknown list of foreigners. The author demonstrates that these fragmm. originally formed part of a chapel of Amenophis II at Karnak and that they belonged to the archetype—formerly thought to belong to Tuthmosis III—of a Ptol. list, a fragm. of which was publ. by MAX MÜLLER, first in *OLZ* 3, 270, and later in his *Egyptol. Researches*, 2, 66 ff. Three of the fragmm. contain the texts usually employed to introduce the names of conquered peoples; 4 refer to people from the N., 8 to people from the S., and 1 to people from both N. and S.

J. SIMONS, *Handbook for the Study of Egn. Topographical Lists relating to Western Asia*. (Leiden, E. J. Brill, 16+223 pp., figs.) sets out in clear and scientific fashion the foreign names given in 34 topographical lists dating from the time of Tuthmosis III to Sheshonk I. Each list is accompanied by a description of its location, and identifications are noted where possible. In an informative introduction to the book the author discusses briefly the historical trustworthiness and topographical value of the lists. List V (p. 127) should be read in the light of an art. by A. FAKHRY, *Ann. Serv.* 37, 39 ff.

J. STURM, *Arch. f. Or.* 11, 400 ff., in a not. of excavations in 1936 at Tanis, mentions a relief showing Ramesses II smiting a Libyan at the feet of the god Atūm.

B. LIBYA, NUBIA AND THE SUDAN

A. M. BLACKMAN, *JEA* 23, 145 ff., gives a preliminary report on the EES excavations at Sesebi, Northern Province, Anglo-Egn. Sudan, 1936-7. Also reported by the same author in *Chron. d'Ég.* 12, 190 ff., and in *Ill. Ldn. News*, Aug. 14.

CAPART, *Les Fouilles d'el-Kab*, *Chron. d'Ég.* 12, 133 ff., records the discovery of some blocks bearing the remains of a mythological text and mentioning Libyan dances.

A. DE COSSON, *JEA* 23, 226 ff., reports on the physical and archaeol. features of Baḥrēn, Nuwēmisah, and El-A'reg in the Libyan Desert.

W. HÖLSCHER, *Libyer u. Aeg. (Aegyptol. Forschungen, 4; 70 pp., figs.)* discusses exhaustively the various types of Libyans which figure on Egn. monuments, and reaches many important conclusions regarding their characteristics and origins.

L. P. KIRWAN, *Studies in the later hist. of Nubia*, *Ann. Arch. Anthr.* 24, 75, quotes GRIFFITH's suggestion (*Ryl. Pap.*, 3, 87, n. 4; 420) that the Meja of Egn. texts represent the Beja of the present day, and adds that, while the identification is possible on philological grounds, there is as yet no further evidence to support it.

O. H. MYERS, *JEA* 23, 117 f., reports on the EES excavations (Sir R. MOND Expedition) at Armant and mentions a particularly fine relief found in the temple of Tuthmosis III, which shows the hand of the king grasping the heads of Nubian and Asiatic prisoners. He also refers to the excavation of a pan-grave cemetery which supplies fresh information concerning Nubian mercenaries of the 2nd Intermediate period. Also reported in *Chron. d'Ég.* 12, 171 ff.

P. E. NEWBERRY, *ZÄS* 73, 139, in a n. on the hierogl. Ⲅ, sees a parallel between the bow used by the Nuers of Baḥr el-Zaref when dancing and a miniature bow used among the Eastern Libyans as a badge of office.

C. PALESTINE, SYRIA, AND ASIA MINOR

W. F. ALBRIGHT, *Arch. f. Or.* 12, 71, revs. favourably *Grundlagen d. aeg.-semitischen Wortvergleichung*, by FR. CALICE, and makes many useful suggestions, particularly with ref. to texts from Rās esh-Shamra.

The same author, *The Egn. Correspondence of Abimilki, Prince of Tyre*, *JEA* 23, 190 ff., commenting on foreign usages and expressions in the Tell el-'Amarnah tablets, points out that the ten letters from Abimilki were actually written by an Egn. scribe. Many features of both linguistic and hist. importance emerge from this treatise.

H. BAUER, *Der Ursprung des Alphabets (Alte Or. 36, H.1/2)*; rev. by L. TH. LEFORT, *Muséon* 50, 397 ff.

K. BITTEL, *Arch. f. Or.* 11, 395 f., in a not. of recent excavations at Boğazköy, mentions the discovery of correspondence with Eg.

By the same author, *Boğazköy. Die Kleinfunde der Grabungen 1906-12*, Leipzig.

M. CHÉHAB, in an art. publ. in *Bull. du Mus. de Beyrouth* 1, 1 ff., entitled *Un Trésor d'orfèverie syro-ég.*, describes a remarkable collection of jewellery which has been put at the disposal of the Lebanon Republic by the Antiq. Dept. of Palestine. The collection, numbering 67 pieces, contains many objects which resemble specimens in the treasures found by DE MORGAN at Dahshūr and by MONTET at Byblos. There can be no doubt concerning the Egn. origin of many of the pieces, especially of a pectoral bearing the name of Amenemmes III which resembles the one found at Dahshūr so closely as to suggest that it came from the same workshop. There are, however, also in this collection many objects belonging to types not found in Eg., but resembling specimens from Rās esh-Shamra and Byblos. Possibly the collection was pillaged from a royal tomb in Byblos.

R. DUSSAUD in his not. in *Syria* 18, 403, of *Die Palästina-Literatur*, ed. by P. THOMSEN, Livraison 1 and 2, singles out for mention Ch. 6 by A. MORET dealing with the travels of Egn. in Asia. For D.'s views on ČERNÝ's *Semites in Egn. Mining Expeditions* see § 13, p. 232.

H. EHLEOLF, in a preliminary report of the Boğazköy excavations (1936), *MDOG* 75, 61 ff., mentions the discovery of a few fragmm. of letters written in Akkadian forming part of a correspondence with Eg. The author, however, claims no special significance for them.

E. O. FÖRRER, *The Hittites in Palestine, II*, *PEQ*, 100 ff., draws on the information supplied by the 'Amarnah letters when discussing the different types of 'Hittites' in Palestine and fixing their geographical positions.

I. J. GELB, *AJSL* 53, 253 ff., locates Shanhar, which is mentioned both in the 'Amarnah and in the Boğazköy letters, in N. Syria, possibly near Aleppo.

N. GLUECK, *Explorations in E. Palestine*, III, *Bull. ASOR* 65, 8 ff., remarks that the rapid growth and great wealth of the Nabatean kingdom was due to its geographical connexions with Syria, Arabia, and Eg.

H. GRIMME, *Zu der altsinaitischen Inschr. Nr. 363*, *Arch. f. Or.* 12, 59 ff., points out that the name DII which occurs in this inscr. is not Semitic, but that it corresponds to the Egn. *ndst*, 'the little one'.

M. GUENTCH-OGLOUEFF, *Astarté syrienne et le ded d'Osiris*. *Rev. d'égyptol.* 1, 197 ff., figs.

E. HENSCHEL-SIMON, *The Toggle-Pins in the Palestine Archaeol. Mus.*, in *Quart. Dept. Antiq. Palest.* 6, 169 ff., points out that the sudden and frequent appearance of the toggle-pin in M.B. II seems to be connected with the Hyksos culture.

A. JIRKU, *Die äg. Listen palästinensischer u. syrischer Ortsnamen (Klio, Beiheft 38, N.F., H. 25)*. A very useful hand-book containing transcr., accompanied by full annotations, of 27 lists of place-names in Palestine and Syria. Rev. by R. DUSSAUD, *Syria* 18, 394 ff. Also rev. by C. J. MULLO WEIR, *Ann. Arch. Anthr.* 24, 174.

C. N. JOHNS, *Excavations at Pilgrims' Castle, 'Atlit (1933): Cremated Burials of Phoenician Origin*, *Quart. Dept. Antiq. Palest.* 6, 121 ff., who had in a previous art. (*op. cit.*, 2, 41 ff.) shown that shaft graves of the 5th and 4th cents. B.C. found at 'Atlit, though fundamentally Phoenician, display some Egn. and Gk. elements, finds confirmation of his dating of the cremated burials of about the 7th cent. in the discovery in one of the graves of an Egn. scarab of either Osorkon III or Sheshonk IV.

G. LOUD reports on the excavations of the Oriental Inst. of Chicago at Megiddo in *Ill. Ldn. News*, Oct. 16 and 23. Among the objects discussed are many which display Egn. design and motifs, including some magnificent ivories.

M. E. L. MALLOWAN, reporting on his excavations at Chagar Bazar in *Ill. Ldn. News*, Mar. 27, states that he found a number of copper cornet-shaped objects in the bottom of jars and suggests that they formed part of a wine-drinker's outfit and belonged to a type which was imported into Syria from Eg. The author includes a photo. of a mould showing a god and a goddess separated by a Syrian version of the Egn. *wankh*.

P. MONTEP, *Les Reliques de l'art syrien dans l'Ég. du Nouvel Empire (Publms. de la Faculté des Lettres de l'Univ. de Strasbourg, Fasc. 76)*, examines in detail the various scenes in Egn. temples and tombs which depict Syrians and their wares, and also a number of Syrian objects found in Eg. After discussing briefly the Egn. texts accompanying the scenes, he gives a detailed analysis of the objects represented. Ch. 4 is devoted to a study of the Keftiu without, however, any very conclusive arguments being adduced as to their origin. The interrelation of Syrian and Egn. art is fully discussed, their points of resemblance compared, and their differences noted.

J. PENDLEBURY, reporting on the results of excavations at Tell el-'Amarnah during the season 1936-7 in *Chron. d'Ég.* 12, 180 f., mentions among other 'finds' a complete Mycenaean vase and a Cypriote vessel with its contents.

G. POSENER, *Une Liste de noms propres étrangers sur deux ostrr. hiérat. du Nouvel Empire, Syria* 18, 183 ff., discusses two important ostrr. at the Louvre (E. 14354 and 14355), apparently dating from Dyn. 19 and containing 14 Syrian proper names, 10 of which were previously unknown. The docs. are also of value for the light they throw on syllabic writing.

H. RANKE, *Keilschriftliches, ZÄS* 73, 90 ff., discusses a new Tell el-'Amarnah tablet already publ'd. by G. DOSSIN in *Rev. d'Assyriologie* 31 (Paris, 1934), 125 ff. From this tablet we learn that 40 women from Gezer were transported to the harem of Amenophis III, bringing the known total of foreign women in the harem to 428, which, as the author points out, must have been responsible for a considerable introduction of foreign blood into Eg. in Dyn. 18. In the same art. a number of important linguistic parallels between cuneiform and Egn. are considered.

A. ROWE, *A Catalogue of Egn. Scarabs, Scaraboids, Seals and Amulets in the Palestine Archaeol. Mus. (Govt. of Palestine Antiq. Dept.)* Cairo, 1936. xlviii + 347 pp., 38 pls., graphs, diagrams, and a map. The catalogue contains descriptions of more than a thousand scarabs, ranging in date from Dyn. 12 to 26, and, in addition to its archaeol. value, demonstrates the extent of the penetration of Egn. products of this period into Palestine. A very useful feature of the book is a table of Egypto-Canaanite contacts.

H. SCHÄFER, *Eine nordsyrische Kultstätte?*, *ZÄS* 73, 54 ff., describing the great stela found at Rās esh-Shamra in 1932, compares certain aspects of the monument with a monument found at Tell Defennah, which is now in the Cairo Mus. The style of the monument is certainly Egn., and the sculptor, though probably not an Egn., must have come under Egn. influence.

C. F. A. SCHAEFFER, *Les Fouilles de Ras-Schamra-Ugarit — 8me Campagne, Rapport sommaire, Syria* 18, 125 ff., describes a most interesting stela. On the stela, which is uninscribed, is a scene of a person presenting

an offering before a seated god, probably El, and its close resemblance to Egn. monuments of its kind is very marked. The style suggests that it is of the time of Dyn. 18 or 19. Another object discussed is a weight in the form of a human head, which, it is claimed, owes its inspiration to Eg. Also reported in *Arch. f. Or.* 11, 392 ff., and in *Ill. Ldn. News*, Feb. 20.

E. A. SPEISER, *Some Animal Figurines of Billa and Gawra*, *Bull. ASOR* 68, 10, 13, describing excavations at Tell Billa, reaffirms his view already stated in *Museums Journal* 23, 273, that pottery from Tell Billa IV possesses affinities with the ethnic movements which were to culminate in the Hyksos conquest of Eg., although he no longer believes in the Anatolian origin of the ware in question.

J. L. STARKEY, in his lecture at the Wellcome Inst. on July 16, reported in *PEQ*, 228 ff., mentioned many interesting Egn. objects found at Lachish, particularly a scarab of 'Aa-ḥetep-Rē^c of Dyn. 16, Hyksos scarabs bearing the name of Apophis, and a small pottery bowl with an inscr. in hieratic, which GARDINER and ČERNÝ date to the 13th-12th cents. B.C. The bronze dagger found in an earlier excavation, which bears an inscr. related to the Sinaitic writing, was also discussed. The excavations are also reported in *Ill. Ldn. News*, Nov. 27, and in *Rev. archéol.* 10, 254 ff.

J. VANDIER, *A propos d'un dépôt de provenance asiatique trouvé à Tod, Syria* 18, 174 ff., discusses the nature and provenance of the Eṭ-Ṭūd treasure. Before drawing his conclusions he outlines the main sources of information for relations between Eg. and Asia during the M.K. The treasure probably does not represent booty, because everything points to Eg. and Asia being at peace at the time. Various considerations lead the writer to think that it represents tribute levied by the Egn. king from a Phoenician prince. This provenance is supported on different grounds by R. DUSSAUD, *ibid.*, 405, in a rev. of O. EISSFELDT, *Eine Einschmelzungsstelle am Tempel zu Jerusalem (Forsch. u. Fortschr.* 13, 163 f.).

R. WEILL, *Sur la situation hist. et politique de Ras Shamra, L'hist. des Religions*, 174 ff., cites hist. evidence from Egn. sources when commenting on two recent arts. by C. VIROLLEAUD.

W. D. VAN WIJNGAARDEN, *De Weg, dien de Israëlieten volgden bij hun uittocht uit Egypte. Oudheidkundige Mededeelingen uit het Rijksmuseum van Oudheden te Leiden, N.R.*, 18, 6 ff., carte.

G. E. WRIGHT, *Palestine in the Chalcolithic Age*, *Bull. ASOR* 66, 21 ff., discusses the sequence of pottery in Palestine during the 5th and 4th Millennia, mentioning points of contact with Egn. pre-dyn. cultures, especially that of Ma'ādi, for the date of which the author claims that Palestinian pottery furnishes a guide.

Id., *The Trogodytes of Gezer*, *PEQ*, 67 ff., divides the early Bronze Age in Palestine into four phases and links them up with their corresponding periods in Eg., adopting for his purpose the minimum chronology. The first phase falls in the Late Predyn. Period, the second in Dyn. I, the third in the Pyramid Age, and the fourth in the First Intermediate Period. The points of resemblance between the Egn. and Palestinian wares are noted.

D. MISCELLANEOUS

F. W. v. BISSING, *Das angebliche Weltreich der Hyksos*, *Arch. f. Or.* 11, 325 ff., comments on the statement in *Das Hethiterreich* by A. GÖTZE (1928) that the Hyksos Empire extended to Crete and Babylonia and that its centre was in N. Syria. In von B.'s view there is no evidence to demonstrate a *Weltreich* of Hyksos either Aryan or Anatolian, let alone European, and he favours the view that the foreign elements (*e.g.* the name Khian) were simply conveyed by them from Palestine.

J. FRIEDRICH, *Das Siegel des Hethitischen Königs Hattusili III nach der aeg. Fassung seines Vertrages mit Ramses II. (Artibus Asiae curat editionem R. HADL, Lipsiae, vol. VI, fasc. 3, 4, 177 ff.)*

P. GILBERT, *Un Relief égyptisant dans les tombes royales d'Our*, *Chron. d'Ég.* 12, 27 f., commenting on a relief of a copper shield found by WOOLLEY at Ur, sees in the motif traces of Egn. influence. The writer maintains that the example serves to emphasize the closeness of the relationship which existed in archaic times between Eg. and the East.

A. S. HEMMY, *Analysis of the Petrie Collection of Egn. Weights*, *JEA* 23, 39 ff., concludes that the Stater and Khoirine standards were introduced into Eg. by the Hyksos. The importance of the Daric standard at Naukratis from Dyn. 26 to the Ptol. period, whereas in the remainder of Eg. it was unimportant, is held to indicate 'that a conspicuous element of the trade of Naukratis was with ports on the Asiatic coast'.

L. KEIMER, *Pendeloques en forme d'insectes faisant partie de colliers ég.: Notes additionnelles*, *Ann. Serv.* 37, 142 ff., remarks on the use of the grasshopper as an amulet against plagues of this insect and mentions that it played an important part in religious and superstitious ideas in both Eg. and Asia Minor. It is clear that in both Eg. and Assyria the grasshopper was regarded as a menace.

G. STEINDORFF, *Ein bronzener Gefässuntersatz*, *ZÁS* 73, 122 f., describing a bronze vase-base in the

Field Mus. of Nat. Hist., Chicago, mentions that the 'palmette' motif has been regarded as 'Phoenico-cypriote' by C. BOREUX, who suggests that this method of decoration displays Asiatic influence. The author, however, considers it to be a pure Egn. motif, and where there are similarities in Asiatic art they are rather due to Egn. influence.

F. H. WEISSBACH, *ZDMG* 91, 80 ff., mentions a Persian plaque with a cuneiform inscr. found at Şakḫārah.

7. Geography and Topography

G. CATON-THOMPSON and E. W. GARDNER's *The Desert Fayum* (1934) is revd. at length and very favourably by G. A. WAINWRIGHT, *JEA* 23, 125 ff.

A. DE COSSON's *Notes on the Bahrēn, Nuwēmisah, and El-A'reg Oases in the Libyan Desert* (*JEA* 23, 226 ff.) contains information of geogr. as well as of archaeol. interest.

Text C of G. GOYON's *Les Travaux de Chou et les tribulations de Geb* (*Kēmi* 6, 1 ff.) contains a list of cities and localities situated in Upper and Middle Eg., including the Fayyūm.

M. HAMZA in an art. (*The Statue of Meneptah I found at Athar en-Nabi and the Route of Piṣankhi from Memphis to Heliopolis*, *Ann. Serv.* 37, 233 ff.) claims that Athar en-Nabi is the site of the temple of Atūm at Kheriṣaḥa (Babylon), visited by Piṣankhi on his way from Memphis to Heliopolis.

A. JIRKU's *Die äg. Listen palästinensischer u. syrischer Ortsnamen* (*Klio*, Beiheft 38, N.F., H. 25) is favourably revd. by CAPART, *Chron. d'Ég.* 12, 204, and C. J. MULLO WEIR, *Ann. Arch. Anthr.* 24, 174.

H. KEES's *Die Laufbahn des Hohenpriesters Onhurmes von Thinis* (*ZÄS* 73, 77 ff.) refers to the 'Eastern Bḥdt' in the Thinite Nome, the mod. Nag' el-Mashāyikh = Lepidontopolis. *Oasis*, a long and important art. by K., appears in *PW*, xvii, 1681 ff.

L. P. KIRWAN's instructive and entertaining *Studies in the later Hist. of Nubia* (*Ann. Arch. Anthr.* 24, 69 ff.) contains some matter of topographical interest.

E. LUDWIG's *Le Nil* (Paris, 1936-7) is revd. by S. T., *Tendances*, Aug. 15, 162, 235 f.

In his *Le Naos D 29 du Mus. du Louvre* (*Rev. d'égyptol.* 1, 161 ff.) A. PIANKOFF discusses the geogr. position of *Mryt*, *Mfkt* and certain other Delta Towns.

Most welcome is the appearance of PORTER-MOSS, *Top. Bibl.*, v: *Upper Egypt: Sites*. Oxford, xxiv + 292 pp. Revd. by R. O. FAULKNER, *JEA* 23, 271.

M. RAPHAEL suggests in *Nouveau Nom d'une pyramide d'un Amenemḥēt* (*Ann. Serv.* 37, 79 f.) that *B*; (𓆎) -'Imn-m-ḥst is the name of the pyramid of Amenemmes III.

A. ROWE's *A Cat. of Egn. Scarabs* (see § 6 C) contains a good n. on the locality *Šnw*t and a useful index of place-names.

A. VARILLE in his *Nouvelles Listes géogr. d'Aménophis III à Karnak* (*Ann. Serv.* 36, 220 ff.) publs. 6 granite blocks belonging to the bases of 3 colossal statues of Amenophis III, which possibly once stood in his funerary temple. Apart from laudatory and other inscr. they bear lists of Asiatic and African peoples and strongholds conquered or held by the Pharaoh in question.

In *Bélier du Fayoum et 21e nome de la Haute-Ég.* (*Bull. Inst. fr.* 36 [1936-7], 129 ff.) R. WEILL argues in favour of the Fayyūm being regarded as the 21st Upper-Egn. Nome. He inclines to the view that *Smn-Ḥr* and *Šn'-ḥnw* are identical with *Šdt*.

C. E. WILBOUR's *Travels in Eg.* (Brooklyn, 1936) is revd. by L. P. KIRWAN, *JEA* 23, 272 f.; G. ROEDER, *OLZ* 40, 418 f.; A. CHILDE, *Boletim do Museu Nacional* [Rio de Janeiro] 12 (1936), 93 ff.; A. W. SHORTER, *Museums Journ.* 37, 72 f.; CAPART, *Chron. d'Ég.* 12, 71 f. See also CAPART, *Bull. Acad. Roy. de Belgique (Classe des Lettres)*, 1936, 395 f.

A short not. of H. E. WINLOCK's *Ed-Dākhleh Oasis* (New York, 1936) appears in *Syro-Egypt* 1, 14.

E. ZIPPERT (*Arch. f. Or.* 11, 400) gives a short account (derived from a report in *The Times*, Jan. 7) of W. B. K. SHAW's expedition to the S. part of the Libyan desert.

The following works have not been accessible to me:—

G. CATON-THOMPSON, E. W. GARDNER, and S. A. HUZAYYIN's *Lake Moeris: Re-investigations and some Comments* (*Bull. Inst. d'Ég.* 19, 243 ff.).¹

C. KUENTZ's *Toponymie ég.* (*Bull. Inst. d'Ég.* 19, 215 ff.).

J. SIMONS's *Handbook for the Study of Egn. Topograph. Lists relating to W. Asia*, Leiden.²

¹ But see under § 1, p. 215.

² But see under § 6 A, p. 224.

8. History

W. F. ALBRIGHT, *The Egn. Correspondence of Abimilki, Prince of Tyre* (*JEA* 23, 190 ff.) claims that the Egn. queen Meritaten is named in the tenth letter, and that all the letters from Abimilki were written by an Egn. scribe.

F. W. v. BISSING, *Die blauäugige Königin Teje* (*ZÄS* 73, 123 f.), explodes a theory that this queen was a blue-eyed Mitannian princess.

L. BORCHARDT, *Der Krönungstag Ramses' V.* (*ZÄS* 73, 60 ff.), considers that the 'Day of Coronation' ascribed by J. ČERNÝ (*ZÄS* 72, 109 ff.) to Ramesses IV really belongs to his successor.

J. H. BREASTED, *Gesch. Aeg.* (German transl. of his *Hist.* publ. by the Phaidon Press with a supplement on Egn. art by H. RANKE), is revd. by J. C(APART), *Chron. d'Ég.* 12, 60, and A. HERMANN, *OLZ* 40, 607 ff.

W. E. CALDWELL, *The Anc. World* (New York, Farrar & Rinehart), contains sections on Eg.

J. CAPART and G. CONTENAU, *Hist. de l'Orient anc.*, is revd. by R. DE V(AUX), *Rev. bibl.* 46, 150 f., and B.B., *Revue St. Boniface* (Brussels), May, 9 ff.

A. DE BUCK, *The Judicial Pap. of Turin* (*JEA* 23, 152 ff.), gives a valuable transl. and discussion of this important hist. doc., rejecting the theory that it was a fiction subsequently contrived by Ramesses IV.

W. DURANT, *The Story of Civilization*, appears in a French guise as *Hist. de la civilisation. I: Les origines. La Sumérie, L'Ég., La Babylonie, L'Assyrie*, with a preface by the translator, C. MOUREY (Paris, Payot).

G. DYKMANS, *Hist. écon. et soc. de l'anc. Ég.*, vols. 1 and 2, is revd. by H. DE MORANT, *Ann. d'hist. écon. et soc.* 45, 299 ff.; L. T. LEFORT, *Muséon* 50, 148 ff.; MONTET, *Rev. ét. anc.* 39, 233 ff. Vol. 3 of the same work, which appeared in 1937, is revd. by L. T. LEFORT, *Muséon* 50, 401 ff.

W. F. EDGERTON, *On the Chronology of the Early Eighteenth Dyn. (Amenhotep I to Thutmose III)* (*AJSL* 53, 188 ff.), utters a warning against unconditional acceptance of BORCHARDT's chronological scheme for this period.

W. F. EDGERTON and J. A. WILSON, *Hist. Records of Ramses III. The Texts in 'Medinet Habu' 1-2*, is revd. by É. DRIOTON, *Rev. arch.* 10, 287 f.; A. C(ALDERINI), *Aeg.* 17, 118; and R. D(USSAUD), *Syria* 18, 216 f. For H. KEES's monograph on Hriḥor, see § 15, p. 239.

C. KUENTZ, *La Bataille de Qadech*, is revd. by MONTET, *Rev. ét. anc.* 39, 223 f.

D. MACNAUGHTON, *A Scheme of Egn. Chronology*, is revd. by T. B. BROWN, *JEA* 23, 270.

MONTET, *L'ère de Menophrès (C.-R. Ac. Inscr. B.-L., 418 ff.)* takes the view that the Menophres after whom Theon names the era commencing in 1321 B.C. is Ramesses I and that he was a descendant of the Seth 'A-peḥty of the Stela of 400 Years, whom M. considers to have been a local pre-Hyksos ruler at Avaris. M. would also transfer the date of the commencement of Dyn. 18 from 1580 to 1550 B.C.

A. MORET, *Hist. de l'Orient*, is revd. by CAPART, *Chron. d'Ég.* 12, 59 f.; G. CONTENAU, *Syria* 17, 380 ff.; E. DHORME, *Rev. hist. rel.* 116, 84 ff.; and MONTET, *Rev. ét. anc.* 39, 228 f.

PETRIE, *A New King (Syro-Egypt 2, 10)*, seeks to insert a Sety-mer-amūn immediately before Haremḥab.

K. PFLÜGER, *Haremḥab u. d. Amarnazeit*, is revd. by J. C(APART), *Chron. d'Ég.* 12, 205, and W. WOLF, *OLZ* 40, 677 f.

For J. PIRENNE's arts. on the Instruction for Merikarē, see § 10, p. 230.

For revs. of G. POSENER, *La Première Domination perse en Ég.*, see § 13, p. 234.

A. SCHARFF, *Der hist. Abschnitt der Lehre für König Merikarē* (noted § 10), is revd. by H. D. SCHAEDEL, *Die Welt als Gesch.* 3, 477 ff., and CAPART, *Chron. d'Ég.* 12, 203.

For J. VANDIER on the 11th-Dyn. Intef Kings see under § 14 A, p. 235 (*Et-Tūd*).

A. WEIGALL, *Hist. de l'Ég. anc.*, transl. from the English edn., is revd. by C. PICARD, *Rev. arch.* 9, 105 ff.

R. WEILL, *Bases, méthodes et résultats de la chronologie ég.* and its supplementary vol. *Compléments* are revd. by MONTET, *Rev. ét. anc.* 39, 229 ff.

9. Law

A. DE BUCK, *The Judicial Pap. of Turin* (*JEA* 23, 152 ff.), gives a new transl., with philological comm., of this well-known doc. By allowing the verb-form in 2/1, *iw-ì dît m ḥr n*, &c., its natural sense of a past narrative tense instead of the present employed by previous translators, he fundamentally alters the character of the text, which now appears as an account by Ramesses III of the steps taken by him in the interval between the famous harem conspiracy and his death, rather than an official doc. setting up a court to deal with the participants in the affair. In his conclusion DE BUCK is led to suggest a modification of STRUVE's theory of the great Harris pap., which the former considers may after all have been the work of Ramesses III and not of his successor.

J. ČERNÝ, *Restitution of, and Penalty attaching to, Stolen Property in Ramesside Times* (*JEA* 23, 186 ff.), shows that the feminine word *ḫwt*, known to the *Wb.* from *P. Leiden 352* and recognized by Č. in a hitherto unpubl. ostr. belonging to the Or. Inst. Chicago, as well as in *P. BM. 10335, verso, 21*, is the technical term for the penalty imposed on a convicted thief in addition to the repayment of the stolen property. The *ḫwt* might be assessed at twice or three times the value of the goods stolen, but was sometimes renounced in cases where these were not actually found with the thief.

J. PIRENNE, *Le Servage dans l'Ég. anc. sous les XXI^{me}–XXV^{me} dynasties* (*Recueil de la Société Jean Bodin*, 11 ff.) has not been accessible to me.

The same author outlines the hist. of government in Eg. from the earliest to Rom. times in *Les trois cycles de l'hist. juridique et sociale de l'anc. Ég.* (*Études d'hist. dédiées à la mémoire de Henri Pirenne*, 229 ff.).

Id., *Hist. des institutions et du droit privé de l'anc. Ég.*, Vol. 3: *La VI^e Dyn. et le démembrement de l'Empire*, is revd. by E. SEIDL in *Z. Sav.* 57, 379 ff.

10. Literature

F. DORNSEIFF, *Äg. Liebeslieder, Hoheslied, Sappho, Theokrit* (*ZDMG* 90, 589 ff.), studies the influence of Egn. love-songs on Hebrew and Gk. poetry.

GARDINER, *Late-Egn. Miscellanies* (*Bibl. Aeg.*, 7), publs. a hierogl. transcr., with nn., of *Schülerhandschriften* culled from many sources; not. in *Chron. d'Ég.* 12, 195 ff.

H. GRAPOW, *Sprachliche u. schriftliche Formung äg. Texte*, 1936, is revd. by B. VAN DE WALLE (*Chron. d'Ég.* 12, 198 ff.) and by R. O. FAULKNER (*JEA* 23, 269 f.).

M. PIEPER, *Das äg. Märchen*, is revd. by R. O. FAULKNER, *JEA* 23, 130.

J. PIRENNE devotes to *P. Leningrad 1116A* two arts.: *Les Instructions du roi Kheti à son fils Merikara* (*C.-R. Ac. Inscr. B.-L.*, 1936, 289 f.) and *Une Nouvelle Interprétation des instructions du roi Kheti à son fils Merikara* (*J. Sav.*, 12 ff.).

G. POSENER, *Catalogue des Ostrr. hiérat. littéraires de Deir el Médineh*, fasc. 1 and 2, is revd. by M. F. L. MACADAM (*JEA* 23, 271).

A. ROSENVASSER, *Nuevos textos literarios del antiguo Egipto. I: Los textos dramáticos*, is favourably notd. by J. C(APART) in *Chron. d'Ég.* 12, 201.

A. SCHARFF, *Der hist. Abschnitt der Lehre für König Merikarê* (*Sitzungsb. München*, 1936, H. 8) studies the hist. section of *P. Leningrad 1116A*, with transl. and a valuable comm. For revs. of this publ. see § 8, p. 229. *Id.*, *Der Bericht über das Streitgespräch eines Lebensmüden mit seiner Seele* (*Sitzungsb. München*, H. 9) has publ. a complete new transl. and comm. of this well-known but difficult text.

J. SPIEGEL, *Die Präambel des Amenemope u. die Zielsetzung d. äg. Weisheitsliteratur*, is revd. by M. PIEPER (*OLZ* 40, 287 f.). *Id.*, *Die Erzählung vom Streite d. Horus u. Seth in Pap. Beatty I als Literaturwerk* (*Leipzig. Ägyptol. Stud.*, H. 9), has made an interesting study of this mythological story, which he classes as an 'epic'.

11. Palaeography

H. BAUER's *Der Ursprung des Alphabets* (*Alte Or.* 36, H. 1–2), is revd. by L. TH. LEFORT in *Muséon* 50, 397 ff.

L. BORCHARDT in his art. \int *qb* 'Daumen' (*ZÄS* 73, 119 f.) maintains that the sign \int represents the thumb. He cites an inscr. in the cenotaph of Sethos I at Abydos, in which the 'fifth' hour of the night is written with \int , showing that the Egns. regarded the thumb as the fifth finger.

J. ČERNÝ, *Two Puzzles of Ramesside Hieratic* (*JEA* 23, 60 ff.), elucidates a hitherto undeciphered group of signs in *Pap. BM. 10335* and explains a puzzling sign qualifying various food-stuffs on several ostrr. as $\frac{\text{Q}}{\text{f}}$ = 'fresh'. In his *Restitution of, and Penalty attaching to, Stolen Property in Ramesside Times* Č. shows that the determ. of *ḫwt* in *Pap. Leiden 352*, considered doubtful by *Wb.*, is to be transcribed $\overline{\text{C}}$.

For J. S. F. GARNOT's *Une Graphie fautive du verbe* $\rightarrow \int \Delta$ (*Bull. Inst. fr.* 37, 63 ff.) see under § 13 of this Bibliogr.

Chron. d'Ég. 12, 62. refers to P. GILBERT's *Remarque sur le signe* Δ (*Ann. Inst. phil. hist. or.* 3, 155 f.) in which it is suggested that the hierogl. Δ represents a pyramid with its enclosure-wall.

For H. GRAPOW's n. (*ZÄS* 73, 75) on $\frac{\text{X}}{\text{X}}$ = *pruty* see § 13, p. 233.

I have not seen S. H. HOOKE's art., *The Early Hist. of Writing*, in *Antiq.* 11, 261 ff., nor H. JENSON's *Die Schrift in Vergangenheit und Gegenwart* (Glückstadt, 1935, viii + 418 pp., 445 figs. and pls.).

MONTET in his interesting art., *L'Arc nubien et ses emplois dans l'écriture* (*Kémi* 6, 43 ff.), adduces evidence for the view that the sign ¶ depicts a Nubian bow. P. E. NEWBERRY, discussing the same sign in *Note on the Hierogl.* ¶ (*ZÄS* 73, 139), compares the miniature bows of the Nuers with that anciently 'used among the eastern Libyans as a badge of office'.

SETHE's *Das hieroglyph. Schriftsystem* is revd. by A. POHL, *Orientalia* 6, 264 f., and M. F. L. MACADAM, *JEA* 23, 272.

The late J. L. STARKEY sent a most interesting contribution to *Ill. Ldn. News*, Nov. 27, 944 ff., entitled *Palestine Clues to the Origin of the Alphabet: new discoveries at Tell Duweir, the biblical Lachish: hieratic script and art relics revealing early Egn. influence, with other evidence bearing on Old Test. hist.*

I have not been able to lay hands on M. STRACMAN's *Origine et sémantique de quelques hiéroglyphes ég.* (*Ann. Inst. phil. hist. or.* 4 [1936], 963 ff.).

P. SUTTLER and G. VON SELLE's *Bibliographie zur Geschichte der Schrift* is revd. by G. RYCKMANS, *Muséon* 49 (1936), 311 f.

12. Personal Notices

In a rev. of F. CALICE's last work W. F. ALBRIGHT pays a tribute to his memory, *Arch. f. Or.* 12, 71.

W. R. DAWSON, *The First Egn. Society*, in *JEA* 23, 259, gives a brief account of a club for promoting Egn. learning in the middle of the 18th cent.

Obituary nots. of Sir G. ELLIOT SMITH have appeared in *Bull. Ryl. Libr.* 21, 4 ff., by T. H. PEAR; in *Chron. d'Ég.* 12, 231 f., by J. C(APART); in *L'Anthropologie* 47, 419 f., by H. V. V(ALLOIS); and in *Man* 37, No. 59, with pl., by M. YOUNG.

Many journals have publ. arts. in honour of the late A. ERMAN and his fundamental work in Egyptology: *Arch. f. Or.* 12, 95 ff., by A. SCHARFF; *Egn. Gazette*, July 2, p. 6, by G. A. REISNER (not seen); *Forsch. u. Fortschr.* 13, 271, by H. GRAPOW; *JEA* 23, 81 f., by W. E. CRUM; *The Times*, June 30; *ZÄS* 73, v ff., by G. ST(EINDORFF); *ZDMG* 91, 484 f., by H. O. LANGE.

A not. of the late Mrs. N. C. C. GRIFFITH by N. DE G. DAVIES appeared in *The Times*, Oct. 25, and was reprinted in *JEA* 23, 263.

A tribute to Fr. C. LAGIER by P. BOVIER-LAPIERRE appeared in *Chron. d'Ég.* 12, 288 ff., reprinted from *Papyrus* of January.

A brief account of the Prague Oriental Institute's Commemorative Ceremony in Honour of President MASARYK appears in *Arch. Orient.* 9, 438, and speeches by R. HOTOWETZ and B. HROZNÝ are printed *ibid.*, 301 and 302 ff.

In *Le Rayonnement de Silvestre de Sacy, J. Sav.*, p. 17 ff. (continued from 1936), H. DEHÉRAIN refers to DE SACY's attempts to decipher the dem. portion of the Rosetta Stone and his relations with CHAMPOLLION.

A not. of E. SCHIAPARELLI by G. MARRO in *La Voce del Nilo*, Gen.-Feb., 10 ff., I have not been able to see.

Appreciative accounts of the late A. WIEDEMANN appear in *Chron. d'Ég.* 12, 232 f., by CAPART, and in *ZÄS* 73, viii, by H. BONNET.

Brief appreciations of C. E. WILBOUR's work are given in revs. of the vol. of his letters *Travels in Eg.* (1936) in *Chron. d'Ég.* 12, 71 f., and in *JEA* 23, 272 (by L. P. KIRWAN).

13. Philology

W. F. ALBRIGHT points out in *Egn. Correspondence of Abimilki, Prince of Tyre* (*JEA* 23, 190 ff.) that in this batch of letters a few Egn. words have been reproduced in cuneiform, thus giving us the contemporary vocalization of them.

T. G. ALLEN's *Egn. Stelae in Field Mus. of Nat. Hist.* (Chicago, 1936) is revd. in *Chron. d'Ég.* 12, 222 f., by CAPART, who suggests that the formula *šms:f k; m tp hb p; mw h:f* (p. 34) may refer to festivals of the inundation.

A rev. in *Chron. d'Ég.* 12, 62 ff., of *Ann. Inst. phil. hist. or.* 3 (1935, vol. offert à J. CAPART), refers to points of philological interest in arts. by É. CHASSINAT (*À propos d'un mot incertain*) and É. DRIOTON (*Notes sur le cryptogramme de Montouemhêt*).

In his art., *Der Berliner Hocker des Petamenophis* (*ZÄS* 73, 25 ff.), R. ANTHES discusses at length the

obscure formula *Ntr nwtj n NN. di-tw h:f hft k:f &c.*; *ibid.*, 94 ff., he somewhat modifies his interpretation of the formula in question in view of an 18th-Dyn. version which had previously escaped his notice.

L. BORCHARDT, *Denkmäler d. A. R. im Mus. von Kairo. I. Text u. Tafeln zu Nr. 1295-1541 (CCG, Nos. 1295-1808)*, Berlin, 244 pp., 52 pls. The spelling *dšy* for *dšr* in a 5th-Dyn. inser. is to be noted and the strange writing of *sm-tj* (not instanced in *Wb.*, III, 448). Titles not included in M. A. MURRAY's *Index* are *šhd mrt* (No. 1398) and *imy-r hm(w) ntr Skr n Mšty* (No. 1403). In his art. *Der Krönungstag Ramses' V. (ZÄS 73, 60 ff.)*, B. disagrees with ČERNÝ's interpretation of the words *gmgm* and *sd* (see *JEA 23, 249*). In *Drei neue Beispiele von Mondmonatsnamen aus der Zeit der 20. Dyn. (ZÄS 73, 66 f.)* B. discusses the month-names *P-n-rmw*, *P-n-ipt*, and *P-n-int*, which occur on ostr. recently publ. by ČERNÝ, and regards them as month-names of the 'later lunar year'.

H. BRUNNER, *Die Texte aus d. Gräbern d. Herakleopolitenzeit von Siut mit Übersetzung u. Erläuterungen*, 70 pp. (*Ägyptol. Forschungen*, 5). B.'s transl. show, for the most part, a distinct advance on those of his predecessors, and the comm. contains material of considerable philological interest.

P. BUCHER's important work, *Les Textes des tombes de Thoutmosis III et d'Aménophis II, I*, is discussed by MONTET in *Rev. ét. anc.* 39, 224.

F. CALICE's *Grundlagen der äg.-semitischen Wortvergleichung (Beihefte zur WZKM, I, Vienna [1936], 278 pp.)*, which I unfortunately did not see and so could not enter in last year's *Bibliography*, is revd. at length by W. F. ALBRIGHT in *Arch. f. Or.* 12, 71 ff. A. is appreciative, but also critical, and makes many useful suggestions.

J. ČERNÝ in *The Gender of Tens and Hundreds in L. Egn. (JEA 23, 57 ff.)* points out that the definite art. (or its equivalent) can never show the gender of tens but does sometimes show the fem. gender of the word *št* 'hundred'. In another art. in *JEA 23, 186 ff. (Restitution of, and Penalty attaching to, Stolen Property in Ramesside Times)*, Č. maintains (probably rightly) that the word *tw* means 'penalty', and that the words *bn šd(i) twt m-dš:f* (see A. M. BLACKMAN, *JEA 11, 253*) should be transl. 'I will not exact a penalty from him'. In *Deux Noms de poisson du Nouvel Empire (Bull. Inst. fr. 37, 35 ff.)* Č. deals with the words *šr* (= the mod. *kar-kár* or *shál*) and *šss* (Dyn. 19), *dš(s)* (Dyn. 19-20). The transition *šs > dš* has only so far been traced up to the Saite period. In *La Constitution d'un avoir conjugal en Ég. (Bull. Inst. fr. 37, 41 ff.)* he draws attention to the *ἀπαξ λεγ.* , 'marriage-settlement (?)'. Č.'s *Semites in Egn. Mining Expeditions to Sinai (Arch. Orient. 7, 384 ff.)* is notd. by R. DUSSAUD, *Syria 17, 391 f.*, who draws attention to the M.-Egn. writings of what are evidently Semitic personal and ethnic names. The appearance of these names indicates, so D. thinks, that the Israelitish-Canaanite population was already at this date spread over S. Palestine.

É. CHASSINAT's art., *À propos d'un mot incertain (Ann. Inst. phil. hist. or. 3, 107 ff.)*, which discussed the word *mnw* (designation in late texts of a vase sacred to Hathor) is referred to in *Chron. d'Ég.* 12, 62.

J. J. CLÈRE's admirable art., *Le Fonctionnement grammatical de l'expression pri hrw en anc. ég. (Mél. Maspero, I [1935], 753 ff.)* is discussed by MONTET in *Rev. ét. anc.* 39, 238 f. In CLÈRE's *A Note on the grammatical Gender of the Names of Towns (JEA 23, 261)* it is suggested that the suffix *f* in *wnt ht-ntr nt šbdw hwwt:f nt nsu-bit* refers to *ntr* and not to *šbdw*. C. contributes to *C.-R. du groupe linguistique d'études chamito-sémitiques*, 2, 66 ff., an art. entitled *La Chute de l'n du suffixe -čn de l'anc. ég.*

In a rev. in *Chron. d'Ég.* 12, 200 f., of R. COTTEVIEILLE-GIRAUDET's *L'Anc. Ég. et les langues africaines (Rev. anthropol. 46 [1936], 56 ff.)* G. LEFEBVRE criticizes the theory that the Hamitic languages in general and Egn. in particular have affinity with the languages of Negro Africa.

A rev. by H. RANKE (*OLZ 40, 680 ff.*) of W. CZERMAK's *Die Laute der äg. Sprache. Eine phonetische Untersuchung. Tl. 2. Die Laute des Neuäg.* (Vienna, 1934), is both critical and suggestive.

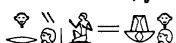
A. DE BUCK's *The Judicial Pap. of Turin (JEA 23, 152 ff.)* contains many important philological nn. In these DE B. points out that *bw rh-i st* can mean 'I do not know who they are', and maintains that in L.Egn. the rel. form has always past reference; that *iw sđm:f* always refers to relative past time; that *sđm:f* = 'he has heard', while *iw:f hr sđm* is used for narrative = 'he heard'; that the negative of *iw:f hr sđm* is *iw:f hr tm sđm*, but of *sđm:f*, *bwpw:f sđm*. He also is of the opinion that narrative *iw:f hr sđm* can continue a past rel. sentence, just as the 1st perf. can continue a perfect rel. sentence in Cop. There is an interesting n. on .

Chron. d'Ég. 12, 62, refers to É. DRIOTON's *Note sur le cryptogramme de Montouemhêt (Ann. Inst. phil. hist. or. 3 [1935], 133 ff.)*. D.'s art., *Une Figuration cryptographique sur une stèle du Moyen Empire (Rev. d'égyptol. 1, 203 ff.)* contains an ingenious rendering of a series of cryptograms on the well-known Louvre stela C 15.

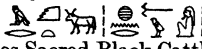
CAPART (*Chron. d'Ég.* 12, 214 ff.) revs. D. DUNHAM's *Naga-ed-Dér Stelae of the First Intermed. Period* (Oxford, vii+124 pp., 34 pls.) and suggests that the title  means not 'Overseer of the Sacred Black (?) Cattle of the *hnrw*', but 'chef des reclus des Sacred Black Cattle'.

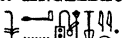

In his useful book, *The Pap. Ebers* (Copenhagen), B. EBBELL maintains that the *swnw* are physicians and the 'Sakhmet-priests' surgeons. The *sw* 'sorcerer' played a useful role 'where a psychic influence was especially needed'. Revd. by CAPART, *Chron. d'Ég.* 12, 223 f. EBBELL publs. an art., *Äg. anatomisch. Namen*, in *Acta Or.* 15, 293 ff.



R. ENGELBACH in his art., *The Statuette of Yi from Elephantine* (*Ann. Serv.* 37, 1 f.), records the rare title .

ERMAN-GRAPOW, *Wb.*: *Die Belegstellen*, Bearbeitet von H. GRAPOW u. W. ERICHSEN, 2. Bd., H. 1-2., ii+192 pp. It is to be hoped that these necessary adjuncts to the *Wb.* will be issued rapidly. Revd. by MONTET, *Rev. ét. anc.* 39, 225 f. ERMAN's last contribution to *Sitzungsb. Berlin* (March 1937, 2 pp.) is entitled *Wb. d. äg. Spr. E.'s Neuäg. Gr.* is revd. by MONTET in *Rev. ét. anc.* 39, 226 ff.

R. O. FAULKNER continues (*JEA* 23, 10 ff.; 166 ff.) his admirable transl. of *P. Bremner-Rhind*. The comm. is full of useful information, philological and otherwise.

GARDINER contributes to *JAOS* 56, 189 f. an interesting art., *The Egn. Origin of some English Personal Names*, and to *ZÄS* 73, 74, an important n., *Late writings of*  'magistrates'. His *Some Aspects of the Egn. Language* (*Proc. Brit. Acad.*, vol. 23) should prove a valuable contribution to linguistic studies in relation to national psychology.

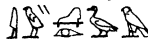
J. S. F. GARNOT in *Une Graphie fautive du verbe*  (Bull. Inst. fr. 37, 63 ff.) explains the vb. , which occurs three times in the inscr. of *Nhbw* (*Urk.*, I, 217 f.), as a corrupt writing of , the engraver having confused it with *sbw* which is normally written with the fish-determinative. His art., *La Stèle de Khou-oui* (*Ann. Serv.* 37, 116 ff.), comprises some philological nn., though, strange to say, he makes no comment on the interesting variant *dj:f šc*, 'may he cross the sand' (see also *Urk.*, I, 252, 13), for the usual *dj:f bš*.

H. GRAPOW has made three interesting contributions to *ZÄS* 73, 44 ff., *Äg. Personenbezeichnungen zur Angabe der Herkunft aus einem Ort*; *Das Alter des Osirishymnus zu Paris* (in which he suggests that the word-order  indicates that the hymn is a M.-K. composition), and *Eine Schriftspielerei aus der achtzehnten Dyn.* (in which he points out that  is a writing of *prwtj*). For revs. of G.'s *Sprachliche u. schriftliche Formung äg. Texte* (1936), see § 10, p. 230; his *Über die anatomisch. Kenntnisse der altäg. Ärzte* is revd. by F. SALVONI, *Aeg.* 17, 290 ff. (very favourably); and his *Untersuchungen über die altäg. medizin. Papp.*, 1-2, by SALVONI, *op. cit.*, 288 f., A. M. BLACKMAN, *Ann. Arch. Anthr.* 24, 169 f., E. V. KRAMLIK, *Orientalia* 6, 143 f., and *Anthropos* 32, 299.

R. HECKER's *Zwei Schalen für Libationen im Berl. Mus.* (*ZÄS* 73, 36 ff.) has some interesting nn. and a list of pers. names containing the element *šht* and of the form .

G. JÉQUIER's *Le Monument funér. de Pepi II, I* (1936), is revd. by A. M. BLACKMAN, *Ann. Arch. Anthr.* 24, 170 ff. (who points out the valuable work achieved by J. in filling up lacunae in the Neferkeré version of the *Pyr. Texts*); B. C. COUROYER, *Rev. bibl.* 46, 475 f.; CAPART, *Chron. d'Ég.* 12, 209 f.; F. LEXA, *Arch. Or.* 9, 448; F. Z., *Aeg.* 17, 123.

H. JUNKER's *Giza II*, which contains much important philological material, is revd. by H. BRUNNER, *Gnomon* 13, 431 ff.

H. KEES's art., *Die Laufbahn des Hohenpriesters Onhurmes von Thinis* (*ZÄS* 73, 77 ff.), contains some valuable philological nn.



C. KUENTZ in *Duplicata d'un vocabulaire* (*Bull. Inst. fr.* 36 [1936-7], 181 f.) discusses some rare words designating mineral products, &c. His *La Bataille de Qadech* is revd. by MONTET, *Rev. ét. anc.* 39, 223 ff.

J. LEIBOVITCH's *Les Inscr. protosinaïtiques* (Cairo, 1934) is revd. by R. BUTIN, *Mizraim* 2 (1936), 81 f.

What F. LEXA says on the subject of 'les formes relatives passives' in his art., *Les Formes relatives dans la langue anc. ég.* (*Arch. Orient.* 9, 311 ff.), does not altogether accord with the views of most authorities on Egn. grammar. *Ibid.*, 1 ff., he continues his treatise, *Les Participes indéclinables dans la langue anc. ég.* (see *JEA* 23, 250 f.).

V. LORET's art. in *Mél. Maspero*, I, *Pour transformer un vieillard en un jeune homme*, is notd. by MONTET in *Rev. ét. anc.* 39, 239 f.

P. MILLER's art., *A family Stela in the Univ. Mus., Philadelphia* (*JEA* 23, 1 ff.), contains some matter of philological interest, viz. a few new personal names and a n. on the rare word *šw*.

MONTET, *Les Tombeaux dits de Kasr-el-Sayad* (*Kémi* 6, 81 ff.), discusses the word *grw* 'narrow', as found in the title *imy-r*  (pp. 87 ff.; see also H. KEES, *ZÄS* 70, 63 ff.), the verb *pns* (p. 94) 'stretch' (?), and a word possibly to be read  (p. 95), not recorded in *Wb*.

M. A. MURRAY and K. SETHE, *Saqqara Mastabas*, II (*Brit. School of Archaeol. in Eg.*, XI). London, vii+32 pp., 8 pls. This vol., which I have unfortunately not seen, is certain to contain much important philological material.

P. E. NEWBERRY, *Funerary Statuettes and Model Sarcophagi*, 2 (*CCG*, Nos. 48274-48575). Cairo, pp. 305-405. This vol. contains little of philological interest apart from the inscr. on Nos. 48404, 48406, 48412, and 48483.

G. POSENER's *La Première Domination perse en Ég.* is revd. by H. BONNET, *OLZ* 40, 612 f.; B. C. COUROYER, *Rev. bibl.* 46, 622 ff.; R. DUSSAUD, *Rev. hist. rel.* 115, 116 ff.; *Syria* 18, 310 f.

H. RICHKE's art., *Der Geflügelhof des Amon in Karnak* (*ZÄS* 73, 124 ff.), has some interesting nn.

A. ROWE's *A Cat. of Egn. Scarabs* (see § 6 C) contains very useful indexes of personal names, and names of divinities and localities.

C. E. SANDER-HANSEN, *Die religiösen Texte auf d. Sarg d. Anchnesneferibre*. Copenhagen, xi+158 pp. Accompanying the texts are a transl. and comm., the latter containing interesting philological material.

H. D. SCHAEDEL's *Die Listen des grossen Pap. Harris* (1936) is revd. by E. OTTO, *OLZ* 40, 357 f.

A. SCHARFF, *Der Bericht über d. Streitgespräch eines Lebensmüden mit seiner Seele* (*Sitzungsb. München*, H. 9). This altogether admirable publ. contains many valuable philological nn. For revs. of S.'s *Der hist. Abschnitt der Lehre für König Merikarē* (1936) see § 8, p. 229.

SETHE's important art., *Die Bau- und Denkmalsteine d. alten Aeg. und ihre Namen* (*Sitzungsb. Berlin*, 1933, xxii, 864 ff.) is revd. by MONTET, *Rev. ét. anc.* 39, 235 f. The new pts. of his *Übers. u. Komm. zu den Pyr.* (Bd. II, Lfg. 1-4, and Bd. III, Lfg. 1-3) are invaluable alike to philologists and students of Egn. religion.

In his *Études de grammaire ég.* (*Acta Or.* 16, 81 ff.) B. H. STRICKER discusses the different verbal forms used to express the perfect and historic past (affirmative and negative) in O., M., and L. Egn., dem. and Coptic; also the synchronous present in L. Egn. and the use of *sdm.f* in dem.

In *Das Pi'el im Äg.* (*ZÄS* 73, 131 ff.) W. TILL comes to the conclusion that there is no evidence for the existence of this verbal form in Egn.

Chron. d'Ég. 12, 64, refers to B. VAN DE WALLE's *Une Stèle ég. du Moyen Empire au Musée Curtius de Liège* (in *Ann. Inst. phil. hist. or.* 3 [1935]), which bears a short inscr. containing an unusual formula.

J. VANDIER's *La Famine dans l'Ég. anc.* is favourably revd. by CAPART (*Chron. d'Ég.* 12, 207 f.), who, however, suggests a different rendering of a passage in the inscr. of Iti (*op. cit.*, 106). Also revd. by MONTET, *Rev. ét. anc.* 39, 237 f.

R. WEILL, *La Signification de pj, verbe 'être réalisé', 'exister'* (*Rev. d'égyptol.* 1, 181 ff.). Many of W.'s conclusions will not be accepted by most of his philological colleagues.

S. YEIVIN's art., *Studies in comparative Egypto-Semitic*, iv (*Kémi* 6 [1936] 63 ff.), is an important additional contribution to the Egypto-Semitic etymologies already suggested by the late A. EMBER and other scholars.

I have not seen the following works and must therefore refrain from comment:

B. COUROYER, *La Lecture du nom d'Horemheb* (*Journ. Palestine Or. Soc.* 17, 100 ff.).

A. FAKHRY, *Sept tombeaux à l'est de la grande pyramide de Guizeh* (Cairo, Antiq. Dept., 1936, 40 pp., 8 pls.).

H. GRAPOW, *Ausgewählte inschriftliche Quellen zur Gesch., Sprache u. Kunst der sog. Mittelmeervölker*. A: *Äg. Quellen* (H. BOSSERT, *Alt-Kreta*, 3. Aufl., Berlin, 49 ff.).

W. C. HAYES, *The Texts in the Mastabeh of Se'n-Wosret-Ankh at Lisht* (*MMA Egn. Exped.*, 12). New York, ix+27 pp., 12 pls.¹

J. JANSSEN, *Aegypt. Philologie* [1934-6] (Jaarbericht 4 [1936] van . . . *Ex Oriente Lux* 173 ff.).

J. LEBOVITCH, *Deux stèles inédites de la déesse Qadech* (*Bull. Inst. d'Ég.* 19 [1936-7], 81 ff.);² *Id.*, *Nouvelles Considérations sur l'inscr. protosinaitique no. 6, autrefois No. 349 de la série publiée par A. H. Gardiner et T. E. Peet* (*op. cit.*, 18 [1936], 157 ff.).

H. F. LUTZ, *Concerning the Significance of the Egn. Particle m(j)* (*Univ. of Calif. Publ. in Semit. Philol.* 10 [1936], 223 ff.); *The Intensifying Conjunction in Egn.* (*op. cit.*, 10, 217 ff.).

P. MILLER, *Stela of Sisopduyehab and his relatives* (*Bull. Univ. Mus. Philadelphia*, 6 [1936], 7 ff.).³

¹ See under § 14 A, p. 236.

² See under § 1, p. 217.

³ See under § 14 A, p. 235.

14. Publications of Texts

(Of the revs. only those which critically discuss publns. of texts are included.)

A. FROM SITES, MUSEUMS, &C., IN EGYPT AND THE SUDAN

'Anibah. G. STEINDORFF, *Aniba*, II (*Antiq. Dept., Miss. archéol. de Nubie 1929-34*. Glückstadt) contains fragmentary texts and texts from small objects, shawabtis, &c.

Edfu. J. S. F. GARNOT, *La Stèle de Khou-oui*, in *Ann. Serv.* 37, 116 ff. Printed text, transl., and discussion, with photo., of a stela from Edfu in the Cairo Mus. (entry No. 66903) with an unusual funerary formula.

Eṭ-Ṭūd. F. B[ISSON DE LA] R[OQUE], *Tód (1934 à 1936)*, *Flles. Inst. fr.* (Cairo), contains many small fragmm. of publ. text. In *Bull. Inst. fr.* 36, 102 ff., J. VANDIER publ. two blocks found by the Inst. fr. at Eṭ-Ṭūd mentioning a King Intef of Dyn. 11 with Horus-name *Shr-ṭwy*, in consequence of which he renumbers the Intef-Kings thus: *Shr-ṭwy* Intef I, *Wsh-ṭnh* Intef II, *Nḥt-nb-tp-nfr* Intef III.

Thebes (Dēr el-Madīnah). M. WERBROUCK revs. C. MAYSTRE, *La Tombe de Nebenmât in Chron. d'Ég.* 12, 211. Some new texts appear in B. BRUYÈRE, *Rapport sur les fouilles de Deir el Médīneh (1933-34)*, 1e partie: *la nécropole de l'ouest*, and in *op. cit. (1934-35)*, 2me partie: *la nécropole de l'est* (Cairo). Two more vols. of the catalogue of hieratic ostrr. of the Inst. fr. have appeared: J. ČERNÝ, *Catalogue des ostrr. hiérat. de Deir el Médīneh (Documents de fouilles . . . , tome 4me, nos. 114-189, tome 5me, nos. 190-241, Cairo)*. These contain descriptions of the ostrr. accompanied by transcr., hand-drawn facsimiles, and photos.

Thebes (Karnak). A. VARILLE, in *Nouvelles Listes géogr. d'Aménophis III (Ann. Serv.* 36, 202 ff.), gives printed texts and photos. of 15 re-used granite blocks from a built-up base between the 10th pylon and the temple of Mût. Six of these, with the names of Amenophis III, have lists of conquered peoples. In *ZÄS* 73, 124 ff. (*Der Geflügelhof d. Amon in Karnak*) H. RICKE publ. the text of a stela of Sethōs II found in 1936 south of the Sacred Lake.

Thebes (Luxor). A. FAKHRY continues his art. on *Blocs décorés provenant du temple de Louxor* in *Ann. Serv.* 37, 39 ff. Those blocks publ. here contain lists of names of conquered peoples. There appear to be no hitherto unrecorded names. A. MORET publ. text and transl. of an 18th-Dyn. copy of an O.-K ritual for temple-dedication in *C.-R. Ac. Inscr. B.-L.*, 239 ff.

Thebes (Madīnat Habū). W. F. EDGERTON, *Medinet Habu Graffiti: Facsimiles* (Chicago). For description see rev. by R. O. FAULKNER in *JEA* 23, 268; also revd. by A. CALDERINI, *Aeg.* 17, 300. The first vol. of the report on the Inst. fr.'s excavation of the temple of Amenhotpe, son of Hapu, near Madīnat Habū (C. ROBICHON and A. VARILLE, *Le Temple du scribe royal Amenhotep, fils de Hapou*, I, Cairo) gives an edn., with transl. and comm., of the texts which led the French archaeologists to their discovery. These are BM 138 (stela in hieratic); Pap. BM 10054, vs. 2, ll. 1-6; dem. Pap. BM 10240; text on a ruined door of the temple itself, seen by LEPSIUS. Some further texts from the temple now excavated appear in the pls., e.g. text on a bas-relief from the interior of the 2nd pylon; fragmm. of painted hieroglyphs. The text on a stela of *Ṭpw-ky*, not included in the vol. here mentioned, but from the basin in the temple precincts, can be seen in a photo. in *Chron. d'Ég.* 12, 179. For revs. of the vol. see § 15, p. 240.

Thebes (Shēkh 'Abd el-Ḳurnah). D. DUNHAM, *Note on some old squeezes from Egn. monuments*, in *JAOS* 56 (1936), 173 ff., has photos. of squeezes containing inscr. from the tomb of Kha'emhēt (tomb 57, PORTER-MOSS, *Top. Bibl.*, I, 88). At least one (Pl. I, a) supplies a more complete version than hitherto publ.

Madāmūd. R. COTTEVIELLE-GIRAUDET, *Rapport sur les fouilles de Médamoud* (1932) (Cairo, 1936), has small and fragmentary texts from loose blocks of Akhenaten.

El-Kaṣr wa es-Ṣayād. *Les Tombeaux dits de Kaṣr-el-Sayad*: hand-copies of remnants of inscr. in three tombs of the O.K. by P. MONTET in *Kémi* 6, 81 ff.

Abydos. P. MILLER, *A family stela in the Univ. Mus., Philadelphia*, in *JEA* 23, 1 ff. and *id.*, *Stela of Sisopduyenhāb and his relatives (Pennsylvania Mus. Bull.* 6, 7 ff.) both give text of the stela in question (PETRIE, *Abydos*, II, Pl. 30, 1, and p. 43), now at Philadelphia. The former publ. is the more complete.

Nag' el-Mashāyikh. H. KEES, in *ZÄS* 73, 77 ff., gives printed text, transl., and discussion of a hitherto unpubl. biographical text from the tomb of *In-ḥrt-ms* (*Die Laufbahn d. Hohenpriesters Onhurmes von Thinis*).

Nag' ed-Dēr. A publ. of great importance to students of stelae, funerary formulae, etc., is D. DUNHAM, *Naga-ed-Dēr Stelae of the First Intermed. Period* (Oxford). Printed texts, with photos., transl., indices of names and titles, and much additional matter from stelae from the Nag' ed-Dēr district, which here includes Shēkh Farag and Nag' el-Mashāyikh (see above), this being in fact one large cemetery of the Thinite nome, excavated by Dr. REISNER.

Dēr Rīfah and *Asyūt*. P. MONTET, *Les Tombeaux de Siout et de Deir Rifeh*, in *Kémi* 6 (1936), 131 ff. (with some photos.) and H. BRUNNER, *Die Texte aus d. Gräbern d. Herakleopolitenzeit von Siut* (Glückstadt). The first is the continuation of a series of arts. on the tombs, with hand-written texts. B. confines himself to tombs 3, 4, and 5 (Asyūt), and of the two versions his is perhaps the better as he keeps to the original direction of the texts.

Eshmūnēn. A. HERMANN publs. short texts from objects found at Hermopolis in 1935 in *Bericht ü. d. Ausgrabungen d. Deutschen Hermopolis-Expedition 1935* (*Mitt. deutsch. Inst. Kairo* 7, 31 ff.).

Lisht. W. C. HAYES, *The Texts in the Mastabeh of Se'n-Wosret- 'Ankh at Lisht* (New York). Facsimiles, with useful lists and concordances of the Pyramid and other funerary texts appearing in the tomb.

Šakkārah. G. JÉQUIER, *Le Monument funér. de Pepi II. 1: Le Tombeau royal* (*Antiq. Dept.: Fouilles à Saqqārah*, Cairo, 1936), contains facsimiles of the texts in the pyramid of Pepi II and of several new texts from the same source. This valuable work, over which much trouble has obviously been taken, is provided with concordances between these and other funerary texts from royal pyramids. The new texts are executed in solid black, the already known texts in outline, and restorations are indicated by dotted lines, a particularly happy arrangement. Rev. by BLACKMAN in *Ann. Arch. Anthr.* 24, 169 f.¹

Gīzah. S. HASSAN, *The Great Limestone Stela of Amenhotep II* (with photos. of text and transl.) in *Ann. Serv.* 37, 129 ff.

Cairo. P. E. NEWBERRY, *Funerary Statuettes and Model Sarcophagi*, fasc. 2 (*CCG, Nos. 48274-48575*). Numerous texts. L. BORCHARDT, *Denkmäler d. A. R. (ausser den Statuen) im Mus. von Kairo, Teil I, Text u. Tafeln zu Nr. 1295-1541* (*CCG, Nos. 1295-1808*). A text on a stela of Dyn. 19 in the Cairo Mus., with photo., is publ. by P. C. LABIB in *Ann. Serv.* 36, 194 ff. (*The Stela of Nefer-ronpet*). G. STEINDORFF, in *Ann. Serv.* 36, 161 ff., publs. 177 scarabs with names of private persons from the collection of H.M. KING FŪ'AD I, presented to the Cairo Mus. (*Skarabäen mit Namen von Privatpersonen d. Zeit des M. u. N. R. . .*). The art. is provided with indices of names and titles. A limestone block in the Cairo Mus.

mentioning a pyramid , perhaps that of Amenemmes III, with photo., in M. RAPHAEL, *Nouveau Nom d'une pyramide d'un Amenemhēt* (*Ann. Serv.* 37, 79 f.). A Bubastite monument of uncertain provenance with reliefs and text relating to Prince Takelot, later King Takelot III, is publ. with photo. in *Ann. Serv.* 37, 16 ff. (*Un Curieux Monument des dynasties boubastites à Héracléopolis Magna*), by H. GAUTHIER. The text is of interest as it states the titles of Takelot before he became king. A short n., with photo., on a small statuette in the Cairo Mus., perhaps from Elephantine, by R. ENGELBACH, *Statuette of Yi from Elephantine*, in *Ann. Serv.* 37, 1 f. An art., *Two unpubld. Coffins in the Egn. Mus.*, by M. KAMAL in *Ann. Serv.* 37, 125 ff.

Ismā'īliah. G. GOYON, *Les Travaux de Chou et les tribulations de Geb, d'après le Naos 2248 d'Ismaïlia*, in *Kémi* 6, 1 ff. This text was copied and publ. in 1890 by GRIFFITH in *Tell el Yahūdīyeh* (EEF 7th memoir), Pls. 23-6 and pp. 70-4. It reappears now in a new hand-written edn., accompanied by photos. and transl. The text is reversed: in the original it reads from r. to l.

Tanis. G. GOYON, *Trouvaille à Tanis de fragmm. appartenant à la statue de Sanousrit Ier, No. 634 du Mus. du Caire*, in *Ann. Serv.* 37, 81 ff. Text and photos. of the statue with the newly-discovered fragmm. in place. Texts from 13 obelisks of Ramesses II at Tanis (hand-copies with photos.) are publ. in *Kémi* 5, 104 ff., by P. MONTET and G. GOYON (*Les Obélisques de Ramsès II*).

B. FROM MUSEUMS, &C., OUTSIDE EGYPT

Berlin. R. ANTHES, *Der Berliner Hocker des Petamenophis*, contains texts from statue Berlin 23728 in *ZÄS* 73, 25 ff. The author adds to his remarks in *ZÄS* 73, 94 ff. Interesting inscrr. from two vessels, Berlin 18514 and 18901: R. HECKER, *Zwei Schalen für Libationen im Berl. Mus.*, *ZÄS* 73, 36 ff.

Chicago. T. G. ALLEN, *Egn. Stelae in Field Mus. of Nat. Hist., Anthropol. Series*, 24, 1, Chicago, 1936, has photos. and translms., accompanied in many cases by hand-copies, of 50 funerary stelae from Dyn. 11 to the Cop. period. The only evidence for their provenances appears to be derived from the texts. Some of the photos. of the stelae with difficult texts might have been reproduced upon a larger scale. Revd. by A. W. SHORTER in *Museums Journal* 35, 439.

Leiden. Transcr., transl., and discussion of a small hieratic pap. *P. Leiden 352* by J. ČERNÝ in *JEA* 23, 186 ff. (*Restitution of, and penalty attaching to, stolen property in Ramesside times*). Texts from several Egn. antiquities, partly in photo. and partly hand-copied, in W. A. VAN LEER, *Egyptische Oudheden, met*

¹ See also under § 13, p. 233.

een inleiding van Dr. W. D. van Wijngaarden (*Mededeelingen en verhandelingen van . . . Ex Oriente Lux*, Leiden, 1936).

London (BM). I. E. S. EDWARDS, *A Toilet Scene on a Funerary Stela of the M. K.*, in *JEA* 23, 165 (a short n. on BM stela 1658 with photo. and transl.). C. E. SANDER-HANSEN's *Die religiösen Texte auf d. Sarg d. Anchmesneferibre, neu herausgegeben und erklärt* (Copenhagen) is what its name proclaims it to be, and has been thoroughly carried out. The letterpress is in autographed form with hand-written texts, not accompanied by facsimiles or photos. There are several new textual readings.

London (University College). A. W. SHORTER, *The Pap. of Khnemehab in Univ. Coll., London*, in *JEA* 23, 34 ff. Somewhat fragmentary texts from an unusual funerary pap. of the Memphite, not Theban, school. With photos.

Paris. A. PIANKOFF, *Le Naos D 29 du Musée du Louvre*, in *Rev. d'égyptol.* 1, 161 ff. Texts with figs., photo., and discussion. G. POSENER, *Une Liste de noms propres étrangers sur deux ostrr. hiérat. du Nouvel Empire*, in *Syria* 18, 183, facsimiles and transcr. of two 19th-Dyn. ostrr. in the Louvre.

C. MISCELLANEOUS

P. BOBROVSKY and V. VIKENTIEV, *Collection of Antiquities purchased in Syria and Eg.* (Paris). Such texts as appear on these objects are publ. All very small.

CAPART revs. J. VANDIER, *La Famine dans l'Ég. anc.*, in *Chron. d'Ég.* 12, 207 f., and G. POSENER, *La Première Domination perse en Ég.*, in *Chron. d'Ég.* 12, 206 f., mentioning his own discovery of a fragm. at El-Kâb with a cartouche of Darius in which the □ is written.

É. DRIOTON, *Rev. d'égyptol.* 1, 203 ff., explains some further cryptographic texts from (a) architrave E. of 1st court of temple of Luxor (Leps., *Dkm.*, III, 149 b), (b) 'love scene' in Beni Hasan 17 (Leps., *Dkm.*, II, 143 b), (c) jambs of door of sanctuary of Sokar in temple of Sethôs I at Abydos, (d) 'Naples stela' (*Bull. Inst. fr.* 30, 369 ff.), (e) stela Louvre C 15. The art. is accompanied by photos. and line drawings (*Une Figuration cryptographique sur une stèle du Moyen Empire*).

GARDINER, *Late-Egn. Miscellanies (Bibl. Aeg., 7, Brussels)*, following on *Late-Egn. Stories* (1932), contains examples of most kinds of Egn. composition except fiction. The following papp. are included: Bologna 1094; Anastasi II, III, III a, IV, V, VI; Sallier I, IV verso; Lansing; Koller; 4 from Turin, designated Turin A, B, C, D; Leiden 348 verso; Rainer 52. Autographed transcr. with textual nn. opposite. An exceedingly useful work.

GARDINER, *A priest of King Tuthmosis III and Prince Wadjmose*, in *Orientalia* 6, 358 f. A fragmentary limestone statuette, with text, of *Pj-wih*, priest of Tuthmosis III and lector-priest of Prince Wadjmose, probably identical with the *Pj-wih* of *Ann. Serv.* 1, 107, no. 22.

G. LOUKIANOFF, *Les Statues et les objets funéraires de Peduamonapet (Ann. Serv. 37, 219 ff.)*.

C. MAYSTRE, *Les Déclarations d'innocence (Livre des Morts, Chapitre 125) (Cairo)*, is a complete and useful edn. of Spell 125 with the variants, transl., nn., and indices.

15. Religion and Magic

M. ALLIOT, in *Un Nouvel Exemple de vizir divinisé dans l'Ég. anc. (Bull. Inst. fr. 37, 93 ff.)*, deals at length with a 5th-Dyn. vizier and nomarch of the 2nd Upper Egn. Nome named Isi, who was divinized after his death, like Imhōtep, Kagemni, and Amenhotpe son of Hapu, and was the object of a local cult in his own city of Edfu during the M.K. and Second Intermed. Period.

Ann. Inst. phil. hist. or. 4 (1936) = *Mél. Franz Cumont* is revd. by CAPART, *Chron. d'Ég.* 12, 202 f.

A. M. BADAWI's *Der Gott Chnum* (Glückstadt, 62 pp., 13 figs.) is a useful and well-illustrated study. Fig. 9, p. 19, however, has nothing to do with Khnūm as bringer of the inundation, but depicts him making a gesture of greeting (see *Wb.*, II, 203, 9-12).

V. BISSING's *Äg. Kultbilder der Ptolomaier- u. Römerzeit* (1936) is revd. by W. SCHUBART, *Gnomon* 13, 218 f.

An art. by the same author, *Sul tipo dei sistri trovati nel Tevere*, appears in *Bull. Soc. arch. d'Alex.* 31, n.s. 9, 211 ff.

F. BISSON DE LA ROQUE's art., *Le Lac sacré de Tôd (Chron. d'Ég.* 12, 157 ff.), describes the sacred lake at Et-Ṭūd, which consisted of two basins, one inside the other, to suit the variations in the level of the water at different seasons of the year. The lake has two stairways, one for descent and one for ascent.

A. M. BLACKMAN's arts., *Preliminary Report on the Excavations at Sesebi, Northern Province, Anglo-Egn. Sudan, 1936-7*, and *Sesebi, Northern Province, Anglo-Egn. Sudan. EES Excavations*, in *JEA* 23,

145 ff. and *Chron. d'Ég.* 12, 190 ff. respectively, mention two boat-shrine supports found in the triple temple, the crypt in the foundations of the central temple adorned with reliefs depicting Amenophis IV (sometimes accompanied by Nefertiti) in the presence of various divinities, and the foundation-deposits discovered under the N.-W. and S.-W. caverns of the temple-substructure. They also refer to a possible small sun-temple of Amenophis IV erected just outside the pre-Aten temple-area. See also *Ill. Ldn. News*, Aug. 14, 272 f., figs., and C. PICARD, *Avant la réforme d'Akhenaton* in *Rev. arch.* 10, 254. A short account of a lecture by BLACKMAN on *Temple Worship in Anc. Eg.* is given in *JMEOS* 21, 13 f.

A short n. on W. S. and A. M. BLACKMAN's art., *An Anc. Egn. Symbol as a Mod. Egn. Amulet* (*Ann. Inst. phil. hist. or.* 3 [1935], 91 ff.) appears in *Chron. d'Ég.* 12, 62.

L. BORCHARDT's *Statuen u. Statuetten von Königen u. Privatleuten* is revd. in *Chron. d'Ég.* 12, 70, and *Aeg.* 16 (1936), 347. No. 1359 in B.'s *Denkmäler des A. R. im Mus. von Kairo*, I (CCG), supplies a new example of the *maṣṣabah*-like construction in Saḥurē's jubilee-temple without the obelisk surmounting it (see SETHE, *ZÄS* 53, 55).

A not. of C. BOREUX's art., *Un Type de chevet ég.* (*Ann. Inst. phil. hist. or.* 3 [1935], 97 ff.), appears in *Chron. d'Ég.* 12, 62. Attention is drawn to the symbolic and religious value of these motifs which, inspired by solar and Osirian myths, evoke the idea of ascension and resurrection.

A. M. CALVERLEY and M. F. BROOME's *The Temple of King Sethos I at Abydos* is revd. by A. SCHARFF, *Antiq.* 11, 242 f.

M. A. CANNEY's *More Notes on Boats and Ships in Temples and Tombs* in *JMEOS* 21, 45 ff., discusses the religious significance of ships in Eg. and other countries.

CAPART's discoveries at El-Kāb (see *Rapport sommaire sur les fouilles de la Fondation égyptol. Reine Élisabeth à El-Kab*, in *Ann. Serv.* 37, 3 ff.) included a lion of Sethos I with an image of the King (now destroyed) in front of it, the lion being 'Horus who averts evil' (*Hr ḥsfw dwt*); an inscribed statue recording among other priestly titles that of $\int \int$; and a relief (temp. Tuthmosis II) suggesting that the Nubian god Dedwen was to some extent the object of a cult at El-Kāb. Another inscr. found on the site speaks of 'Osiris Dedwen'. C. has some evidence for his view that the triad worshipped at El-Kāb consisted of Nekhbet, Horus of *Bḥdt*, and Thoth. Several blocks were found having portions of an interesting mythological inscr. See also *Chron. d'Ég.* 12, 133 ff. and 184 f. By the same scholar is the art., *Two Mummy Cartonnages*, in *Brooklyn Mus. Quarterly* 24, 20 ff.

É. CHASSINAT's *Le Temple de Dendara*, I-IV, and *Le Temple d'Edfou* are revd. respectively by É. DRIOTON, *Rev. arch.* 10, 291, and P. MONTET, *Rev. ét. anc.* 39, 221 ff.

Attention should be drawn, perhaps, to A. CHILDE's *Notes sur la philosophie des ég.* in *Annaes da Academia Brasileira de Sciencias* 6 (1934), 57 ff.; 7 (1935), 129 ff.; 8 (1936), 233 ff.

E. BILLE-DE MOT, in a rev. (*Chron. d'Ég.* 12, 216 f.) of R. COTTEVIELLE-GIRAUDET's *Rapport sur les fouilles de Médamoud* (1932): *Les reliefs d'Amenophis IV Akhenaton*, draws attention to the representation of a *Sed*-festival baldaquin in a relief of Amenophis IV publ'd. by GRIFFITH in *JEA* 5, 61.

CAPART (*Chron. d'Ég.* 12, 224 f.), in a rev. of W. R. DAWSON's *The Magicians of Pharaoh* (*Folklore* 47 [1936], 234 ff.), criticizes D.'s statement that magical cures are necessarily anterior to the use of medicines,

R. DUSSAUD, *Cultes cananéens aux sources du Jourdain d'après les textes de Ras Shamra* (*Syria* 17 [1936], 283 ff.) deals with an anc. Phoenician myth representing Anat as a cow-goddess. Her connexion with Hathor is discussed and questioned. A short n. by the same authority, entitled *Encore le dieu Horon* (*Syria* 17, 394), refers to a statue of Ramesses II placed under the protection of the god Haurōn.

ERMAN's *La religion des Ég.* (transld. by H. WILD. Preface by É. DRIOTON. Paris, 514 pp., 8 pls., figs.) is revd. by G. JÉQUIER, *Gazette de Lausanne*, Oct. 31, 1.

In his art., *Three unnumbered Tombs at Thebes* (*Ann. Serv.* 36, 124 ff.), A. FAKHRY draws attention to a representation in the tomb-chapel of Nebmehyt of the deified Queen Nefertari adoring the solar bark.

É. DRIOTON revs. G. FOUCART's *Tombe thébaines: Nécropole de Dirā' abū'n-Naga. Le Tombeau d'Amonos* in *Rev. arch.* 10, 290 f.

GARDINER's *The Attitude of the Anc. Egn. to Death and the Dead* is revd. by F. SALVONI, *Aeg.* 17, 289 f., and A. W. SHORTER, *JEA* 23, 268 f. GARDINER publ's in *Orientalia* 6, 358 f., the inscr. on the lower portion of a seated limestone statuette of Pwah, a *wēb*-priest of Tuthmosis III and lector (*ḥry-ḥbt*) of the Prince Wadjmōse.

J. S. F. GARNOT in his *Le Tribunal du grand dieu sous l'Anc. Empire ég.* (*Rev. hist. rel.* 116, 26 ff.) maintains (with some justification) that the 'great god' mentioned in the threats to unsuitable visitors, which are found in tomb-chapel inscr. of the O.K., is not the king but a god—Rēc or Osiris (see his n. 1, p. 32).

In *Un Curieux Monument des dynasties boubastites à Héracléopolis Magna* (*Ann. Serv.* 37, 16 ff.), H. GAUTHIER suggests that the *Imn pꜣ ist* of the monument in question may be identical with *Imn (-Rꜥ) m (or n) pꜣ iw, ist* being often confused with *iw* in the late period.

For G. GOYON's *Les Travaux de Chou et les tribulations de Geb d'après le naos 2248 d'Ismailia* (*Kémi* 6 [1936], 1 ff.) see § 14 A, p. 236.

H. GRAPOW and H. SCHÄFER, *Eine ungewöhnliche äg. Darstellung der Sonnenbarken* (*ZÄS* 73, 97 ff.), show that in the well-known scene depicting the goddesses of the East and West each standing in the bow of her boat and passing the sun's orb from one to the other, the boats in question are supposed to be lying not bow to bow but side by side.

In *Les Trois Protecteurs de notre cité* J. GRIMOND (*Chron. d'Ég.* 12, 239 f.) maintains that the protectress of Paris during the Rom. Empire was the goddess Isis.

M. GUENTCH-OGLOUEFF discusses in *Astarté syrienne et le dd d'Osiris* (*Rev. d'égyptol.* 1, 197 ff.) a scarab which displays a nude female standing beside a 𓆎 and a flower. The female, so she thinks, is Astarte = Isis, and she associates her and the *dd* with the legend about the dead Osiris and the *ἐρείκη* related by Plutarch. She dates the scarab to the Hyksos period.

In *The Clearance of a Tomb found at Al-Fostat, 1936* (*Ann. Serv.* 37, 58 ff.), A. HAMADA mentions 414 shawabti figures found in the tomb 'fixed in a quantity of sand in an interesting order', which he describes. The tomb also produced a good collection of amulets.

W. C. HAYES's *Royal Sarcophagi of the XVIIIth Dyn.* is revd. by M. S. SHAW (*JMEOS* 21, 51 ff.), who refers to the information concerning the religious and funerary doctrines of the N.K. which the texts engraved upon these royal sarcophagi supply. Revd. also by É. DRIOTON, *Rev. arch.* 10, 283 f.

In *Zwei Schalen für Libationen im Berl. Mus.* (*ZÄS* 73, 36 ff.) R. HECKER publs. some interesting inscr. comprising dedications to Satis and Anukis and an anc. text, of which other examples exist dating from M.-K. to Ptol. times, representing the sources of the Nile as being at Heliopolis.

W. A. HEIDEL's *Hecataeus and the Egn. Priests in Herodotus Bk. II* (*Memoirs of the Amer. Acad. of Arts and Sciences* [Boston], 18, 2 [1935], 53 ff.) is revd. by PH. E. LEGRAND in *Rev. ét. anc.* 38 (1936), 457 ff.

In *Herihor u. die Aufrichtung d. thebanischen Gottesstaates* (*Nachr. Göttingen, Fachgruppe 1, Altertumswiss., N.F. Bd. 2, Nr. 1* [1936]) H. KEES maintains that the usurpation of Hrihor was not a victory of the clerical party; rather it was the rise to supreme power of an unscrupulous adventurer, who, as commander-in-chief of the army and viceroy of Nubia, made use of his great sacerdotal position, to which his birth gave him no claim, to further his own ends. He was also greatly assisted by Theban jealousy of the political and administrative position assigned by the Ramessides to their residential city in the Delta. K. has much that is interesting to say on the meaning of *whm-mswt*, and asserts that it denotes a new Theban era introduced by Hrihor himself in yr. 19 of the reign of Ramesses XI. The inscr. publ. by K. in the art., *Die Laufbahn des Hohenpriesters Onhurmes von Thinis* (*ZÄS* 73, 77 ff.), contains a number of priestly titles. K. discusses the practice, which first becomes noticeable in Dyn. 19, of appointing retired soldiers and civil-servants, who were of high standing but not members of priestly families, to important sacerdotal positions, so supplying them with a permanent income in their old age.

For L. KEIMER's views on the use of the grasshopper as an amulet see § 6 D, p. 227.

The inscr. publ. by P. C. LABIB in *The Stela of Nefer-ronpet* (*Ann. Serv.* 36 [1936], 194 ff.) contains an interesting curse beginning with the words, 'As for him who shall remove my name in order to insert his own name . . . '.

In *Chron. d'Ég.* 12, 202, is a short not. by CAPART of I. LEVY's *Autour d'un roman mythologique ég.*, publ. in *Ann. Inst. phil. hist. or.* 4 (1936), 817 ff.

G. LOUKIANOFF's *Une Statue parlante ou oracle du dieu Ré-Harmakhis*, *Ann. Serv.* 36, 187 ff., describes a limestone bust of a hawk-headed god which L. thinks was used for the giving of oracles.

A short not. of A. MORET's *Rituels agraires de l'anc. Orient à la lumière des nouveaux textes de Ras Shamra* (*Ann. Inst. phil. hist. or.* 3 [1935], 311 ff.) appears in *Chron. d'Ég.* 12, 63. The same scholar's *Texte rituel du début de l'anc. Empire reproduit au temple d'Aménophis III à Louxor* is publ. in *C.-R. Ac. Inscr. B.-L.*, 239 ff.

H. MÜLLER in his *Unters. ü. Darstellungen von Gebärden auf Denkmälern des A. R.* discusses among other gestures those of priestly officiants performing various religious rites, and those of mourners on the occasion of a death or at funerals.

PETRIE has put together much useful material in *The Funeral Furniture of Eg.* (*Brit. Sch. of Archaeol. in Eg.*, 59, London, x + 30 pp.). His *Shabtis* is revd. by M. A. MURRAY in *Man*, 69 f.

R. PETTAZZONI's *La confessione dei peccati*, II: *Egitto, Babilonia, Israele, Arabia meridionale* is revd. by G. COPPENS in *Muséon* 50, 145 f.

A. PIANKOFF thinks that the figurine discussed in *Sur une statuette de Bès* (*Bull. Inst. fr.* 37, 29 ff.) represents Bès inspiring a flute-player on whose shoulders he is mounted. The reliefs and texts publ. by P. in *Le Naos D 29 du Musée du Louvre* (*Rev. d'égyptol.* 1, 161 ff.) depict and refer to the god Osiris *Mryty*, divinities male and female personifying prosperity (cf. BORCHARDT, *Sahure*¹, II, 108 f.), divinities of the Osirian cycle, the Heliopolitan ennead, the Hermopolite ogdoad, divinities of important cult-centres, and local divinities or divinities worshipped in the neighbourhood of *Mfkt*¹ (whence the shrine came), some of whom occur comparatively rarely.

CH. PICARD contributes two nn., the one entitled *Sanctuaires au Palatin* and the other *Homère et les religions d'Ég.*, to *Rev. arch.* 10, 110, and 8 (1936), 213, respectively.

CAPART revs. briefly in *Chron. d'Ég.* 12, 202 f., J. PIRENNE's *Le Culte funéraire en Ég. sous l'Anc. Empire* (*Ann. Inst. phil. hist. or.* 4 [1936], 903 ff.).

K. PREISENDANZ points out in his art., *Oamoutha* (*PW*, XVII, 1675), that two different etymologies have been suggested for this name.

For L. PRON's *La Grande Pyramide et sa signification* see *Le Vieux Bistouri*, Suresnes, Feb. 20, 1 ff.

H. RICKE in *Ein Tempel mit Pfeilerumgang Thutmoses' III. u. Hatshepsuts in Karnak* (*Ann. Serv.* 37, 71 ff.) describes a small temple (recently uncovered at Karnak) dedicated to 'Amūn on his terrace'. It was erected by Tuthmosis III and altered by Hatshepsut. One of the foundation-deposit pits presents an unusual feature, and the deposits themselves, though crude, are of some interest. In his art. in *ZÄS* 73, 124 ff., *Der Geflügelhof des Amon in Karnak*, R. publs. a stela which records Sethos II's rebuilding of a poultry-farm for Amūn. This lay on the S. side of the sacred lake at Karnak, and the ruins of it, as restored yet again by Psamat (who also rebuilt the series of store-houses adjoining it), are still quite recognizable.

A brief but favourable not. by CAPART of C. ROBICHON and A. VARILLE's *Le Temple du scribe royal Amenhotep, fils de Hapou*, I, appears in *Chron. d'Ég.* 12, 211. Revd. also by É. DRIOTON, *Rev. arch.* 10, 286 f.; P. MONTET, *Rev. ét. anc.* 39, 224 f.; F. Z., *Aeg.* 17, 301 f.

G. ROEDER in his *Bericht ü. die Ausgrabungen der Deutsch. Hermopolis-Expedition 1935* (*Mitt. deutsch. Inst. Kairo* 7, 1 ff.) describes a M.-K. temple discovered by him at Hermopolis. This consisted mainly of an open court with two trees, which, R. thinks, was the original sanctuary of the Hermopolite Ogdoad (p. 8), who, from Dyn. 19 onward, resided in the 'Sethos temple'. The site of the 'primordial mound' has not yet been located.

A. ROWE, *A Cat. of Egn. Scarabs* (see § 6 C). R. supplies a useful n. on the god *Hr-imy-šnw*t (see also *ZÄS* 64, 126 f.; and GARDINER, *Hierat. Pap. BM*, III, 113, n. 1). The book also contains an index of names of divinities.

A. RUSCH has contributed a long and most instructive art. on *Nun* to *PW*, XVII, 1462 ff. He points out that this divinity had no cult, priests, or ritual of his own. He always remained merely the personification of an element.

H. SCHÄFER in *Eine nordsyrische Kultsitte? Zum grossen Denkstein von Ras Shamra* (*ZÄS* 73, 54 ff.) compares with the monument in question one displaying similar features found at Tell Defennah. In *Eine unerkannte Trauergebärde u. ein angeblicher 'Plötzlicher Tod' in Reliefs des A. R.* (*ZÄS* 73, 102 ff.) he discusses two representations of an unusual (female) mourning-gesture, and also shows from a parallel scene that the man depicted collapsing is not the suddenly stricken 'Ankhma'hor but a relative displaying excessive grief.

S. SCHOTT's *Das Löschen von Fackeln in Milch* (*ZÄS* 73, 1 ff.) is a long and important art. in which it is shown that there are grounds for supposing that when Amūn visited the temple at Dēr el-Bahari the pedestal supporting his boat-shrine was surrounded with 4 small tanks containing milk. These were covered with wooden gratings in which lettuces were inserted, the lower ends of these vegetables being in the milk. Round the pond of milk thus formed were set 4 'Nile-figures', the impersonations of the 4 tanks, holding tapers which were lit at night. Strangely enough S. does not refer to the obvious connexion between the milk and the white juice of the lettuces. The milk was doubtless supposed to increase the juice of the plants and so add to their efficacy as an aphrodisiac (see GARDINER, *Ch. Beatty Papp.*, No. I, p. 22). It was, of course, owing to the sexual properties which they were supposed to possess that lettuces figure so prominently in the cult of the ithyphallic fertility-gods Min and Amūn.

A. W. SHORTER's *The Egn. Gods* (London, xiv + 144 pp., 4 pls.), though intended mainly for the general public, contains much useful information. The same scholar in his art., *The Pap. of Khnememhab in Uniu.*

¹ See Piankoff, *op. cit.*, 174.

Coll., London (*JEA* 23, 34 ff.), points out that this early 19th-Dyn. copy of the *Bk. Dead* was produced under the influence of Memphite theology and that it displays some interesting and unusual features, including a representation of the 4 enemies mentioned in the *Book of Overthrowing 'Apep*.

J. SPIEGEL's *Die Idee vom Totengericht in der äg. Religion* is revd. by A. POHL, *Orientalia* 6, 263 f.

G. STEINDORFF and W. WOLF's *Die Thebanische Gräberwelt* is revd. by R. O. FAULKNER, *JEA* 23, 129 f. (who points out that the authors, doubtless by a slip of the pen, wrongly place Siptah and Queen Tawesret at the end of Dyn. 20), and by A. POHL, *Orientalia* 6, 265 f.

An interesting description of the temple of Amenhotpe, son of Hapu, by A. VARILLE and C. ROBICHON appears in *Ill. Ldn. News*, Jan. 2, 12 f., under the heading *A 'Christopher Wren' of Eg. more richly shrined than Pharaohs, and later deified: Discoveries at Luxor*. An art. by the same two authors, entitled *Quatre nouveaux temples thébains*, in *Chron. d'Ég.* 10 (1935), 237 ff., is referred to in *Syro-Egypt* 1, 14 f.

R. WEILL publs. in *Bull. Inst. fr.* 36 (1936-37), 129 ff., an interesting art., *Bélier du Fayoum et 21e nome de la Haute-Ég.* He maintains that an ivory tablet of *Wdymw* and an entry on the *Palermo Stone* show that even by the middle of Dyn. 1 religious syncretism was so far advanced that the ram-god of the Fayyūm, originally the ram-god of Heracleopolis Magna, had already obtained a place in the temple of the crocodile-god of that region.

WEILL's *Le Champ des roseaux et le champ des offrandes dans la religion funéraire et la religion générale* is revd. in *Syro-Egypt* 1, 12 f., and by H. BONNET in *OLZ* 40, 91 ff. B., while regarding the book as a most useful source of information, contests the theory that the Field of Reeds and Field of Offerings denoted the E. and W. limits respectively of the sun's daily journey across the sky. Also revd. by P. MONTET, *Rev. ét. anc.* 39, 229 ff.; É. DRIOTON, *Rev. arch.* 10, 291 ff.; and A. W. SHORTER (who comments very favourably upon it), *JEA* 23, 292.

E. ZIPPERT's *Theben-West* (*Arch. f. Or.* 11 [1936-7], 398 ff.) contains a short but excellent description (illustrated) of the funerary temple of Amenhotpe, son of Hapu. *Ibid.*, 12, 94 f., Z. describes the subterranean burial-places of sacred hawks and apes in the cemetery of Hermopolis, and also the sacred enclosure planted with trees, arranged round a deep well dating from the Rom. period.

I could not lay hands on the following works and therefore am unable to comment upon them:

A. J. ABUBAKR, *Unters. ü. die äg. Kronen*. Glückstadt, xx+72 pp., 14 pls., 46 figs.

E. BAES, *Les Dieux sadiques*. Brussels, Henri Kumps, 154 pp.

A. BAYOUMI, *Survivances ég.*, in *Bull. Soc. Roy. de Géogr. d'Ég.* 19, 279 ff.¹

E. BLOCHET, *Sur le Phénix*, in *Muséon* 50, 123 ff.

E. COULON, *Le Spiritualisme en Celtique, en Grèce, en Ég. et l'hypothèse atlantidienne*. Montbéliard, 1936, 32 pp.

G. D. HORNBLLOWER, *Osiris and his Rites*, in *Man* 37, 153 ff.; 170 ff.; 199 (additional n.: *Hathor and the Pharaoh*).

A. KAYSER, *Die Tempelstatuen äg. Privatleute im m. u. im n. R.* Dissert. zur Erlang. d. Doktorwürde, Heidelberg, 1936, 66 pp.

J. LEIBOVITCH, *Deux Stèles inédites de la déesse Qadech* (*Bull. Inst. d'Ég.* 19 [1936-7], 81 ff.).²

C. MAYSTRE, *Les Déclarations d'innocence (Livre des Morts, Chap. 125) = Recherches d'archéol. de philol. et d'hist.*, 8. Cairo, Inst. fr., vii+163 pp.³

H. RANKE, *Ägypter als 'Götterkinder'*, in *Corolla, Ludwig Curtius zum 60. Geburtstag dargebracht* (Stuttgart), 180 ff.

M. WEBBROUCK, *La Décoration murale du temple des Mentouhotep*, in *Bull. des Mus. Roy. d'Art et d'Hist.* (Brussels), 36 ff.

J. A. WILSON, *Illuminating the Thrones of the Egn. Jubilee*, in *JAOS* 56, 293 ff.











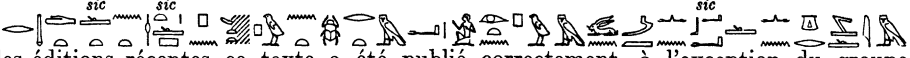

¹ But see under § 1, p. 214.

² But see under § 1, p. 217.

But see under § 14 C, p. 237.

BRIEF COMMUNICATIONS

Sur un Passage de la Stèle Louvre C 1

L'INSCRIPTION verticale de la stèle C 1 du Louvre commence par les phrases suivantes (d'après l'original):  etc. Dans les éditions récentes ce texte a été publié correctement, à l'exception du groupe  (cf. fig. 1) qui a toujours été interprété fautivement. On l'a lu:  (Maspero, *Étud. de myth.*, 3, p. 162),  (Pierret, *Rec. d'inscr. du Louvre*, II, p. 28), [] (Piehl, *Inscr. hiérog.*, Série I, 2^e part., p. 3),  (Brugsch, *Thesaurus*, 1467), ou bien, en reproduisant tel quel le signe mutilé:  [sic!] (Gayet, *Stèles de la XII^e dyn.*, pl. 1),  (Max Müller, *OLZ* 3 (1900), 48),  (Breasted, *AJSL*.21 (1904-5), 155); en dernier lieu, Sethe a donné la forme  qu'il a lue *whꜥt* (*Lesest.*, p. 82, l. 11 et n. c; *Erläut.*, p. 132). Extérieurement la copie de Max Müller est exacte, mais son interprétation—il lit *mꜣt* 'Wahrheit'¹—est impossible à cause de la forme même du signe mutilé² et du fait qu'il y a deux *⊖*. La lecture de Maspero, avec , et toutes celles qui en découlent, rencontrent également des obstacles: le signe est trop peu recourbé pour pouvoir être ; un mot  avec deux *t* est non seulement inconnu, mais d'une forme à laquelle on ne peut guère s'attendre dans le cas présent.



La véritable lecture du groupe est en fait . La forme du signe mutilé convient pour  comme on peut en juger par les autres exemples de ce signe se trouvant sur la stèle (figs. 2, 3, 4). Cette lecture explique la superposition et le déplacement sur la droite des deux *⊖* (cf.  fig. 2).



FIG. 1





FIG. 2





FIG. 3



FIG. 4

Le terme est un substantif féminin (cf. ) *mt(r)t* ou *mt(y)t* dérivé soit de l'adjectif *mtr* (*mty*?) 'exact', soit du verbe *mtr* (>*mty*) 'témoigner'.³ Dans une biographie de la XVIII^e dyn. (*Urk.*, IV, 973) ce dernier mot apparaît précisément dans un contexte semblable à celui de  sur Louvre

C 1:  'cela dont je viens de *témoigner* (= de me porter garant), ce sont mes qualités (réelles), il ne s'y trouve pas d'exagération; cela, c'est réellement mon caractère, il ne s'y trouve pas d'inexactitudes'.

A la lumière de cet exemple⁴ le mot  de Louvre C 1 apparaît nettement comme un dérivé de *mtr* 'témoigner' signifiant littéralement 'témoignage' et étant par suite probablement identique au mot de même forme (*mtrt*) et de même sens mentionné par le *Wörterbuch* (II, 172, 11-14) et attesté jusqu'à présent seulement en néo-égyptien. La traduction du passage cité au début de cette note doit donc être: 'Quant au récit de cette stèle, c'est un *témoignage* (= un exposé véridique valant un témoignage)⁵ de ce qui a été réalisé par moi, c'est ce que j'ai fait réellement; il ne s'y trouve pas d'exagération ni de mensonges'.

J. J. CLÈRE.

¹ Breasted a lu aussi 'truth' *op. cit.*, 157 et *Anc. Rec.*, I, § 471.

² Le signe  a sur Louvre C 1 sa forme habituelle—cf. II, 4, 16, vertic. 3, et dans la légende de la femme.

³ Sur la distinction de ces deux racines, cf. Gard., *Egn. Gr.*, p. 447, D 50, n. 2.

⁴ Voir peut-être aussi Couyat-Montet, *Hammâmât*, n° 1, l. 9.

⁵ Cette signification est imposée par le contexte: Sethe (*Erläut. Lesest.*, 132), bien que croyant avoir affaire à un dérivé de *whꜥt* 'erklären', a traduit correctement 'wahrheitsgemässer Bericht'.

Recent Discoveries at Şakḫārah

FOLLOWING the discovery of intact magazines in the tomb of Ḥemaka early in 1936 I turned my attention to a large First-Dynasty maṣṭabah which had been partly cleared by Firth, and numbered by him as 3036. This tomb, like that of Ḥemaka, proved to have a hollow superstructure divided into 32 magazines, all unfortunately plundered. Examination of the burial-chamber revealed the existence of four magazines, two on each side of the chamber, which was built below ground-level underneath the magazine superstructures. Two were found intact with pottery *in situ*. Sealings revealed the name of the owner as Ankhka, a high official of King Wedimu (sealings of his were found by Petrie at Abydos, cf. *Royal Tombs*, I, Pl. xxi, 29). These magazines and the burial-chamber were exceptionally well preserved, and complete details of the methods of timber roofing, &c., were revealed. Another surprising feature was a trench surrounding the superstructure beyond the enclosure-wall. This was filled with mud to form a bed for rows of trees, the roots of which were found spaced out at regular intervals of 2 ft. They are now being examined.

Tomb No. 3038, the burial-chamber of which was partly cleared by Firth, was re-examined with astonishing results. From an architectural point of view it is by far the most interesting example of First-Dynasty building yet discovered. It had undergone three distinct and radical changes in design, all apparently made by the owner, Nebetka, an official under Wedimu. The building after the first clearance presented the usual features of a typical First-Dynasty maṣṭabah—a hollow brick superstructure with magazines and palace-façade on all four sides, with a descending stairway on the east side leading to a great rock-cut pit divided by brick walls into the burial-chamber and subsidiary rooms. Here again full details of the wooden roofing were procurable, together with definite evidence of a second storey in the pit itself.

The most interesting discovery at this point of the excavations was the finding of a second rock-cut pit beside the pit with the burial-chambers. This was untouched, and was found to contain high brick-built shelves on three sides, in which were set granaries with unique pottery lids and small doors at the bases. All these doors were sealed with the name of the owner Nebetka, hitherto unknown.

The high floor-level of the magazines in the body of the superstructure suggested the probability of something being buried under the rubble and sand filling, and with this in view I removed the south side of the palace-façade. We were rewarded with the discovery of a second superstructure, which consisted of a raised brick-paved terrace surrounding a pyramid structure arranged in steps carefully built of brick and plastered (see Pl. xiii, 2). Having completely disclosed this conception of the architect we then removed the terrace and found the steps of the pyramid continuing below it to the ground-level. The original design was thus revealed as a form of oblong step-pyramid covering subterranean burial-chambers.



The tomb of Sabu, dated to Ḥenedjyeb, was reported in the press. Besides a fine series of objects we found Sabu himself in the original burial posture, which curiously enough was semi-extended and not contracted.

Another important discovery in our last season was two very unusual First-Dynasty tombs dated to Ḳa'a and having burial-chambers cut out of the face of the cliff. The superstructures of one of these tombs retained well-preserved painted designs on the walls, similar in many respects to those of Ḥesyrē, although many of the designs are entirely new. The objects from all these tombs, including wooden labels, pottery, and stone vases, form a large collection and will vastly increase the existing one in the Cairo Museum. The objects from the tomb of Ḥemaka are already on exhibition, and the publication of this discovery should be out in about two months.

There is little doubt that systematic excavation of the long-neglected Archaic Cemetery at Şakḫārah would yield a wealth of information hitherto undreamed-of by the archaeologist.

WALTER B. EMERY.

The Egyptian for 'in other words', 'in short'

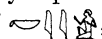
VERY nearly fifty years ago W. Max Müller rightly explained  in the expression  *P. Bol.* 1086, 15 as an unorthographic writing of , recalling the fact that in *P. Bulaq IV*

the regular spelling of the word for 'other' is ; see *Rec. trav.* 13, 152, n. 5. This correct explanation has been either rejected or forgotten, see Erman, *Neuäg. Gr.*, § 675 ('als Vertröstung'), Wolf in *ZÄS* 65, 93 ('nachdrücklich'), *Wb.*, v, 85 (2) (under the conjunction *kr*). The context in the Bologna papyrus is reasonably clear. A Syrian slave allotted to the temple of Thoth had not been delivered, and the writer of the letter has made investigations. First he went to the chief herald of the army, but that officer 'excused himself(?)¹ with me, and said in effect (or 'in sum', lit. 'in other words') that the Vizier had acquired' the slave. Erman quotes as other instances *P. Harris* 500, rt. 5, 11, and *P. Leyd.* 367, 5. Both passages are extremely obscure: the letter presents difficulties of reading and the love-song is certainly corrupt, though in this latter I am inclined to render: 'The love of my brother is my concern when I am alone, for my heart does not cease sending me speedy messages that come and go saying to me that he has wronged me, [in] other words, that thou hast found another.' This rendering is so venturesome, however, that two fresh confirmations of Max Müller's view are doubly welcome. The more decisive is an ostrakon just published, Černý, *Ostr. hiér.* . . . *Deir el Médineh*, No. 235. A lady named Ēse here makes an appeal saying: 'Let me be given the places (*i.e.* burial-places?) of Panekhu my husband.' Thereupon, 'inquiry was made with regard to the opinion of the notables, and they said: "The woman is in the right." Then the places of her husband were given to her.' The text concludes: 'In other words, she was taken² for him', *i.e.* regarded as his successor. The other passage is on an ostrakon in the possession of Dr. Černý, who kindly allows me to quote from it. A woman, writing to her sister, says that her husband threatens to divorce her. The couple are apparently abroad, and the husband complains that the wife's family do not pay him or her any attention, nor do they send provisions as is usual in such cases. He ends: 'In short, you must (lit. 'shall', for *iw t r*) say something, or you will return to Egypt.' Such is the translation I propose; Dr. Černý had suggested: 'If you say something, you will go back to Egypt.' We may easily both have failed to grasp the sense, but it matters little; evidently sums up the husband's reproaches and states the conclusion to be drawn from them.

It goes without saying that not every combination of with is an example of the phrase here discussed. Thus *Anast. V*, 9, 8 is doubtless the particle +*šdm-f* form. In the *Hittite Treaty*, 20, no subject follows, so that *ky ḏd* may be meant, but the passage is too much damaged to have evidential value. In *P. Mag. Harris*, 10, 1 is very obscure. I owe these three examples to Gunn. Pleyte-Rossi, *Pap. Turin*, 17, 8 () to which Černý calls my attention at the last moment, involves some unpublished additions and is too difficult a passage to be discussed here.

The idiom *m kr ḏd* is interesting in several ways. It is rare to find phrases beginning with a preposition introducing a clause or serving as a conjunction; I can name, besides the expression here discussed, only and . For me, however, the principal interest is to find a new illustration of the principle that Late-Egyptian orthography is a perverse kind of phonetic script, see *JEA* 16, 229-31. It is highly dangerous to explain any Late-Egyptian writing by an etymology based on mere visual inspection; we must always try to divine what *sound* may have been intended.

ALAN H. GARDINER.

'The Reading of the Egyptian word for Necropolis'

IN *Sup. Gard. Egn. Gr.*, 3 (addition to p. 63, § 81) I wrote: 'In view of the derivative *hrty-ntr* "necropolis worker" and the later writings it might be worth while considering whether the old reading *hrt-ntr* should not be retained after all', and I quoted Sethe's discovery that is to be

¹ The verb *šhw* requires further investigation. Wolf and *Wb.* give 'leugnen', but here the suffix must apparently be reflexive.

² Černý marks the verb as of doubtful reading. However, the det., though cursively written, cannot be anything else than and this points to *it*.

NOTES AND NEWS

A GRIEVOUS blow has been dealt our Society by the loss of its President, Sir Robert Mond, LL.D., F.R.S., who died on October 22 last. Since his election in 1929 he had been a most munificent supporter of the Society's activities, defraying the whole cost of the Armant Expedition, and aiding us in many other ways. An account of his distinguished career as archaeologist and chemist by one of his oldest friends, Professor Newberry, appears on p. 208.

The Nubian Expedition began its season's work at the beginning of November at 'Amārah West, where a very promising start had been made in February. The personnel consists of Mr. H. W. Fairman (Field Director), Mrs. Fairman, and Messrs. David Bell, Peter Fell, and J. G. MacDonald. Work began with removal of the débris outside the Temple proper, and the discovery that the magazines, originally vaulted, are preserved to a level above that of the lintels shows that the Temple buildings still stand to an even greater height than had been expected. 'Saharan' sherds, found on the surface of the Town and Temple, perhaps indicate, Mr. Fairman thinks, that 'Amārah was the first place on the Nile to be reached by the 'Saharan' people. When the last report was sent good progress was being made with the clearing of the Temple forecourt. Five cemetery sites, two of them apparently representing a culture that has hitherto received little attention, have been located, and will be examined later.

This autumn three important works have been issued by our Society either independently or in conjunction with other bodies. The third volume of *The Temple of King Sethos I at Abydos*, copied by Miss Calverley with the assistance of Miss Broome, and edited by Dr. Gardiner, is of course a joint publication with the Oriental Institute of the University of Chicago. It contains 65 plates, of which 13 are in colour and 24 are photographic, and deals with the set of rooms devoted to the cult of Osiris which lie behind the seven Chapels published in Vols. I and II. Much more use has been made than previously of retouched photographs, which render the delicate reliefs far better than does line-drawing. The price to the public is £6, to Members and Associates £5. That these prices, bearing no relation to the expense of production, should be possible is due to the generosity of Mr. John D. Rockefeller Jr., who has defrayed the entire cost.—*Rock Drawings of Southern Upper Egypt*, I (Sir Robert Mond Expedition), by Dr. Hans A. Winkler, contains forty collotype plates of drawings admirably photographed, mostly in the desert east of the Kīna-Armant stretch of the Nile, and going back to early predynastic times. They give new information about early desert peoples, the fauna of their time, their dress, weapons, boats, and even social life and religion; some of the drawings are by a predynastic people who came across the Red Sea to the Eastern Desert, others by a very early race of hunters; others again throw fresh light on the Blemmyes, and there are some protodynastic Horus-names. The volume is sold to the public at 18s., to Members and Associates at 13s. 6d.—Jointly with the University of California the Society has issued a publication of the Graeco-Roman Branch, *The Tebtunis Papyri*, Vol. III, Part 2, by A. S. Hunt, J. G. Smyly, and C. C. Edgar. It contains 262 business, legal, and administrative documents and letters, and six literary fragments, with four collotype plates. It is sold by the Society to Members, Associates, and subscribing libraries only, at 28s.

We try hard, aided by the judicious Mr. Dakin and our printer's skilled readers, to avoid misprints, with tolerable success on the whole. But to our deep dismay we find that Mrs. Davies's article 'Some Representations of Tombs in the Theban Necropolis', on pp. 25 ff. of this volume, contains five errors which got into the proofs after the author passed them, and for failing to correct which we are responsible: on p. 26, n. 4, p. 36, lines 10 and 23 and n. 2, and p. 40, n. 2, 'N. M.

Davies' should of course have been 'N. de G. Davies'. That these mistakes still leave the authorship of three of Mr. Davies's finest publications in the family is perhaps an extenuating circumstance; but for making Mrs. Davies appear to annex her husband's works in this way we offer our apologies to both concerned. To do anything which might cause domestic unpleasantness is quite alien to the policy of this *Journal*.

Prof. Steindorff sends us the following lines (translated):

'Egyptology has again to bewail a heavy loss. On August 12, in Paris, Ludwig Borchardt died of a heart complaint, in his seventy-fifth year. Thereby a most productive scientific career has come to an abrupt end, and our science has lost one of its oldest and most meritorious representatives. In quite early years Borchardt, stimulated by Heinrich Brugsch, came under the spell of ancient Egypt; endowed with unusual mathematical gifts, he studied in Berlin at the Technische Hochschule, but at the same time applied himself to Egyptology as one of Erman's first pupils, being specially attracted by the hieratic papyri of the Middle Kingdom and by chronological problems. In 1895 he paid his first visit to Egypt, and worked, under the direction of Sir Henry Lyons, at recording the monuments on the island of Philae which were threatened by the Aswān Dam. This, his first excavation, was soon followed by a number of others which he conducted himself, and through which he founded the study of Egyptian architecture as a new discipline. The Sun-temple of Abu Ghorāb and the pyramid-temples of Abušir were explored by him with methods in part taken over from Dörpfeld, and communicated to the scientific world in exemplary publications. Then followed the excavation of El-'Amarnah, the houses and villas of which he made stand forth again. Here fortune granted him one of the finest discoveries ever made on Egyptian soil, a sculptor's studio with portrait-heads of the family and courtiers of the Heretic King, among them the now world-famous bust of Queen Nefretiti. The Great War put an end to this successful undertaking, excavation on the site being later taken over and continued with excellent results by the Egypt Exploration Society.

'Borchardt rendered another great service to science by creating, in conjunction with Maspero, the *Catalogue Général du Musée du Caire*, to which he himself contributed the volumes dealing with statues, among the best of this great publication.

'Acting at first as Scientific Attaché of the German Consulate-Generalat Cairo, Borchardt founded the German Institute of Egyptian Archaeology, at the same time creating as a *dépendance* the German House at Thebes, which opened its hospitable doors not only to his compatriots but also to many non-Germans. When Borchardt reached the age-limit and had to resign his official position, he had no wish for a comfortable and restful old age; full of energy, he made a working-place of his own, an Institute for the Study of Egyptian Architecture, into which he threw his whole scientific energies.

'What rich fruits Borchardt's many-sided activity brought forth is attested by the bibliography published for his seventieth birthday, on October 5, 1933. Pure philology and linguistics excepted, practically every province of Egyptology was studied by him, in particular, of course, those branches to which he could apply his special gifts for calculating and measuring. In Egyptology this investigator, a man of sound judgement, averse from all mysticism, will never be forgotten. May his last creation, the Institute for the Study of Egyptian Architecture, cause Ludwig Borchardt's name "to live for ever and to eternity".'

Shortly after the publication of this Part the Griffith Institute at Oxford will be opened. It will be remembered that Professor Griffith bequeathed his considerable fortune, as a reversion after his widow's death, to the University towards the foundation of 'a permanent home or institute for the study of ancient languages and antiquities of the Near East . . ., comprising departmental libraries, studies, and space for the treatment of collections resulting from explorations and excavations; together with funds for keeping it up and for aiding explorations and excavations', and that he also left his library and scientific papers for the Institute. Mrs. Griffith, who died in October 1937, left her estate for the same purposes. The exact amount which accrues to the University from

the two bequests is still uncertain, but is known to be amply sufficient for the realization of the benefactors' intentions. The building, of four storeys, forms an annexe to the Ashmolean Museum; for the Institute will be a department of that Museum, directed by a special Committee. The claims of Egyptology, which the testators expressly directed should receive first consideration, are fully provided for; there is generous accommodation for the splendid library, under a special librarian who is rapidly becoming an enthusiast for Egyptology, and rooms for the Professor and for two enterprises founded and largely maintained by the Griffiths, namely the Oxford University Excavations in Nubia, the finds and records of which at Kawa are being worked upon for publication by Mr. Macadam, and the preparation, by Miss Rosalind Moss and her assistants, of the *Topographical Bibliography of Ancient Egyptian Hieroglyphic Inscriptions, Reliefs, and Paintings*, of which five volumes have appeared. The Reader in Assyriology will have his quarters in the Institute, to which the Museum's Assyriological library is to be transferred. Kindred subjects, among them Greek epigraphy, will have a home there, and there is space for the storage of certain antiquities. Thus through the Griffiths' generosity the University will possess a worthy and long needed centre for teaching and research in Near-Eastern subjects; and there is no doubt that the Griffith Library, which will continue to aim at completeness for all scientific purposes, will attract as welcome visitors foreign as well as English students of Egyptology.

We offer our sympathies to the Director and Members of the Fondation Égyptologique Reine Élisabeth of Brussels in the loss sustained by them through the death, on September 22, of their President of many years' standing, M. Henri Naus Bey.

REVIEWS AND NOTICES OF RECENT PUBLICATIONS

Ancient Egyptian Sculpture lent by C. S. Gulbenkian, Esq. London, The British Museum, 1937. 8vo. ii+28 pp., 32 pls. 2s. 6d.

It is seldom that the public can view a private collection which reveals the spirit and beauty of ancient Egyptian art to a degree comparable with that attained by the great museums, and which is so well-arranged and select that the fine pieces are not seen, as so often, huddled together or in the near vicinity of shoddy or time-worn material. Further, there is nothing here to make the sceptic purse his mouth; even the most attractive pieces seem manifestly genuine. Hence we owe a deep debt of gratitude to Mr. Gulbenkian, who has allowed the public to share the joy of a collector's life and in particular to see again that obsidian head which we were so somnolent or poor-spirited as to allow to leave this country. The late ivory reliefs shown on Pl. xxxi perhaps come next to this in perfection, with a happy union of faultless delicacy and decorative simplicity. In these the highest tribute has been paid by Egypt to its own national art, since, in a short era of awakening after the passing away of most of the glory of Egypt, self-effacing artists chose for their swan songs the repetition of ancient refrains and succeeded in catching all their grace, though not quite all their virile force.

Mr. Sidney Smith, Keeper of the Department of Egyptian and Assyrian Antiquities in the British Museum, in a short introduction indicates the place of each item in the history of Egyptian art, and Mr. I. E. S. Edwards, Assistant-keeper, adds translations of the texts that occur. Both carry out their modest tasks briefly and well. Dating objects by style rarely meets with unanimous acceptance, however. The relief on Pl. xx is almost certainly not earlier than the beginning of Dyn. 19, though of exceptional quality. Perhaps the stela on Pl. xxi is of the same period. I have a feeling that the royal head on Pl. xix comes from a late period and is an archaizing return to 18th-Dyn. forms, carried out with perfect technical skill.

The dexterity with which a *dōm*-palm becomes a toilet-spoon (Pl. xxxii) is a witness to the refinement which had been reached in the later period of the Empire; for the cleverness of the composition, its subtle humour and balance, are on the highest level. The deity named on the statuette of Shepes (p. 25) would seem to be Tutu, son of Neit, rather than of a serpent Utut, as Mr. Edwards pointed out to me in self-criticism.

N. DE G. DAVIES.

The Papyrus Ebers; the Greatest Egyptian Medical Document. Translated by B. EBBELL. Copenhagen, Levin & Munksgaard; London: Humphrey Milford. 1937. 8vo. 135 pp. Dan. Kr. 30.

Dr. Ebbell has long occupied himself in the study of Egyptian medicine, and for some years has made contributions to *ZÄS* and other journals on the subject. He has now accomplished the ambitious task of a complete translation of P. Ebers, and for his energy and perseverance in this he must be awarded the fullest credit. It is unfortunate, however, that what might have been a most valuable contribution to medical history has been put forth in a form that cannot but provoke criticism by Egyptologists. Despite the great progress that has been made in the last thirty years in our knowledge of Egyptian grammar and syntax, the time has not yet arrived when a translation of an Egyptian text can be given to the world without a commentary. It is incumbent upon the translator of any text, be it literary, religious, or what it may, to give a defence of his renderings. Far more is this the case with a long document of a highly specialized nature, which abounds in technical terms demanding full investigation. Dr. Ebbell in his previous articles has attempted the determination of a considerable number of anatomical, pathological, and pharmaceutical terms, but vast quantities of others still await treatment, and in the present work these are either translated into English without any reason being given why such and such a meaning is attributed to such and such a word, or else the Egyptian words are merely transcribed into their conventional symbols. Dr. Ebbell, moreover, seems unwilling to make use of the labours of his colleagues in the same field, as is evidenced, for instance, by the fact that in this *Journal* for the last few years there has appeared a number of articles attempting to determine the identity of certain herbs, drugs, and diseases; but Dr. Ebbell has not in any

single instance adopted the interpretations advanced or even controverted them. Many of his renderings of the technical terms are probable enough, but they require proof; some, however, are quite indefensible and conflict not only with the evidence of the medical texts themselves, but also with that of the magical and literary texts in which some of them also occur. Of the latter texts Dr. Ebbell seems to have no knowledge.

In his Introduction, Dr. Ebbell has given the names of various scholars who have occupied themselves with the study of P. Ebers, but his list is very incomplete. He does not mention the name of Maspero, for instance, who as long ago as 1876 made the first translation of the corrupt and difficult passage dealing with the stomach. And here it may be mentioned in parenthesis that Dr. Ebbell renders *r-ib*, not as 'stomach' generally, but as *cardia* (the anterior orifice of the organ), stating that the Egyptian term 'means literally "the mouth of the stomach"', whereas he should have said 'mouth of the heart'. There is no reason to suppose that the Egyptians attributed any more particular significance to the cardiac orifice of the stomach (where it joins the esophagus) than they did to the pyloric orifice (where it joins the duodenum) and thereby ignored the central part of the organ itself. The medical evidence of the Ebers, Berlin, and Ed. Smith papyri does not support so specialized a meaning of *r-ib* any more than does the reference in P. Sallier II, 7, 3.

Dr. Ebbell, also in his Introduction, ascribes a higher authority to P. Ebers than it is entitled to. The document is by no means distinguished for the purity of its text, and it is quite obviously a heterogeneous collection of remedies, recipes, and wrinkles, collected from numerous sources, altogether analogous to, and just as unscientific as, the 'household recipe books' of Europe which are common in manuscripts from the fifteenth century onwards, and extremely abundant after the invention of printing. The only superiority of P. Ebers over the other so-called medical papyri is the fact that it is longer, and calligraphically a finer MS.; but it is full of the same corruptions and absurdities as all the others, although it does contain, interspersed amongst the purely empirical and magical recipes, a few garbled and corrupt extracts from a more rational book of medicine, parts of which are already known to us in the Kahūn and Ed. Smith papyri.

In enumerating the other medical papyri, Dr. Ebbell should not have omitted mention of the medical texts in the Chester Beatty collection, transcripts of which have been available to him for two years; nor, if he includes the so-called Medical Papyrus of London among such documents, is he justified in omitting the important magico-medical papyri at Leiden (especially I. 343+345), and certain other similar documents.

Dr. Ebbell would have made his book far easier to use if he had indicated the numbers, not only of the pages of the original MS., but also of the lines; and it would have added further to the utility of the book had he inserted in the margins the numbers of Wreszinski's edition of the text, as this edition is that which is most commonly used by students and was indeed used by Dr. Ebbell himself. It is difficult to see the utility of the lists of words at the end of the book, since none of these forms a complete glossary or index, and, save in a few instances, no reference is given for a justification of the meanings adopted.

After the long and painstaking labour of Dr. Ebbell in attempting to supply what is much wanted—a complete translation of P. Ebers, it may seem ungrateful on the part of the present reviewer to make the foregoing strictures. But Dr. Ebbell may be assured that they are kindly intended, and that, had he adopted the methods of modern editors of Egyptian texts and provided a well-documented and fully commented edition with a complete glossary or index, he would have conferred a far greater boon upon all those interested in P. Ebers either as Egyptologists or as medical historians. As it is, Egyptologists will still feel themselves bound to work out afresh any passage they wish to study, and medical historians who do not know Egyptian will still have to take on trust much that requires justification. Let us hope that Dr. Ebbell will regard the present work merely as a preliminary essay and as the precursor of a full and detailed translation of the text.

WARREN R. DAWSON.

Libyer und Ägypter, Beiträge zur Ethnologie und Geschichte libyscher Völkerschaften nach den altägyptischen Quellen. By WILHELM HÖLSCHER. (Ägyptologische Forschungen, Heft 4.) Glückstadt, J. J. Augustin, 1937. 4°. 70 pp., 6 pls. RM. 9.—

The primary aim of this book is to determine the ethnological divisions of the Libyan peoples, their origins, and their relations with Egypt by analysing the representations of them on Egyptian monuments, their other archaeological remains, and the occasional allusions to them contained in the historical literature. The author has accomplished his very complicated task with care and thoroughness, and his arguments, though often involved, are presented with a conviction which is refreshing. Each of his conclusions is based on a statement of the existing evidence, from which the cardinal and fundamental features are sifted. The

first group to be examined is the Tjehenu, the earliest representations of whom occur on monuments of the Old Kingdom, notably on the famous relief in the mortuary temple of Saḥurē. A full critical description of these people, as they appear on that relief, is given, some of their most striking features being the unpractical nature of their dress, which was obviously determined by magical or ritual factors, the close resemblance of some elements of their attire to that of the Egyptian Pharaohs, and the undeniably Egyptian origin not only of their tribal name but also of the names of certain individuals. It is not surprising that, having pointed out these and other less conspicuous but still important traits which find Egyptian parallels, the author sees in the old Tjehenu an Egyptian stock which was squeezed out of the Delta at a very early period and which, while retaining many of its original characteristics, adopted others from its newly acquired African neighbours. He locates their home in the Wādi Naṭrūn and the Fayyūm.

The account of the Tjemehu begins with an analysis of their dress and weapons, from which we learn that they were mainly archers, though they are sometimes depicted with swords. They seem to have flourished at least from the First Intermediate Period until the beginning of the New Kingdom, for after that their name is used, like that of the Tjehenu in earlier times, to indicate Libyans in general, including the Libu and the Mashwesh. Concerning their origin little can be ascertained with certainty, but the author favours the view that they migrated from the south-west to the north-east, and in support of this view, though speaking in guarded terms, he finds evidence in the passage of the C-group of Nubian pottery which has been found by Newbold in the Wādi Hāwa.

It is in his treatment of the Libu and the Mashwesh that the author displays most clearly his ingenuity. There are many elements which are common to the dress of both these peoples, but one feature of the latter, namely, the penis-case, is lacking in the representations of the Libu. The author not unnaturally links up the practice of circumcision with this use of the penis-case—the uncircumcised Libu requiring no such addition to their dress. The much-debated word *krnt* is discussed with full references, and the ultimate conclusion is that it is derived from the Hebrew עָרְלָה—a suggestion already put forward by Brugsch—and that its use corresponds with it in meaning both the foreskin and the uncircumcised phallus.

The historical background of the Libyan supremacy in Egypt and its course are dealt with dynasty by dynasty until the final downfall at the hands of the Ethiopians.

By the publication of this book an important gap in our knowledge of the relations of Egypt with her Western neighbours has been filled, and fresh discoveries must surely confirm at least the main lines of this thesis.

I. E. S. EDWARDS.

Die ägyptischen Listen palästinensischer und syrischer Ortsnamen. By ANTON JIRKU. (Klio, Beiträge zur alten Geschichte, Neue Folge, 25. Beiheft.) Leipzig, Dieterich'sche Verlagsbuchhandlung, 1937. 8vo. 66 pp., 1 pl. RM. 4.—

In this wholly admirable little volume Professor Jirku has succeeded in presenting to all scholars whose interests extend to the many perplexing geographical problems of Syria and Palestine a book of reference which is both comprehensive and commendably brief. It is not for the Egyptologist alone that the book has been written, for every name is transcribed into Roman characters and explanations are given in the accompanying footnotes wherever those unacquainted with the idiosyncrasies of the hieroglyphic script might reasonably be puzzled (*e.g.* p. 7, n. 4). The lists—twenty-seven in number—are arranged in chronological order, beginning with that of Tuthmosis III from the temple of Karnak and concluding with one of Taharḳa, copied by the author from the pedestal of a statue in the Cairo Museum; every place-name which is mentioned more than once is provided on each occurrence with full cross-references, so that it is possible to see at a glance whether the neighbouring places in any given instances coincide. Most of these geographical lists will be familiar to Egyptologists, for they are already included in the works of R. Lepsius, W. M. Müller, K. Sethe, and J. H. Breasted; many have recently been collated anew by the author, and three, from monuments of Amenophis III, Ramesses II, and Taharḳa, are published, so it seems, for the first time. In his identifications, which are given in note form at the first mention of a name, the author has made liberal use of the Old Testament, Tell el-'Amarnah tablets, Hittite records, Ras esh-Shamra texts, and other modern archaeological evidence, as well as giving critical references to the existing geographical works. It was obviously not his intention that these bibliographical references should be exhaustive—a task which would be outside the real purpose of the present volume—so that it would be inappropriate to record here occasional omissions which occurred to the reviewer when reading through the book. Some

brief remarks on the historical significance of the geographical lists and the manner of their composition, followed by an excellent index, conclude this most useful work.

I. E. S. EDWARDS.

Les Reliques de l'Art Syrien dans l'Égypte du Nouvel Empire. By PIERRE MONTET. (Publications de la Faculté des Lettres de l'Université de Strasbourg, Fasc. 76.) Paris, Société d'édition, 1937. 8vo. 189 pp., 207 figs. Fr. 80.

M. Montet has worked extensively in Egypt and for a few productive years in Syria. He ought therefore to be a dispassionate judge when the two countries make rival claims. If in this book he too often plays the part of an advocate who makes the most of points that tell in favour of Syria, his client of the moment, yet on the whole, despite some doubtful arguments, he is not led far from a right outlook or a just verdict.

The author has set out to present the contribution which Syrian objects found or pictured in Egypt can make to a knowledge of Syrian art. He has to show that this material is really Syrian, proving it by parallels drawn from the soil of Syria and by a contrast of styles which may serve as a test of impure imitations. Recent years have immensely increased the material that Syria has contributed to its own history; but this is scattered, uncatalogued, and not very accessible. The Egyptologist will be disappointed to find the well-known Egyptian material profusely illustrated here, but the Syrian material, mainly objects, noted only by references to publications. It is an unhappy division, since it means that photographed objects are set off against line drawings, a chasm not easily bridged by many. This is therefore a book primarily for those less familiar with Egypt, the great museum of ancient painting and representational relief. In this respect the book serves its purpose fairly well, though the sources are never critically treated where suspicions might justly be aroused, no new material is added, and the illustrations are not always taken from the best versions. There do not seem, however, to be many cases where serious error occurs.

The Egyptologist would gladly have exchanged the long verbal descriptions of the illustrations for a clear presentation of the vital questions at issue. What is 'Syria'? Is it modern Syria, Syria of classical times, or Syria as an ancient geographical term? Is it Phoenicia, or the city-states of the time of the Egyptian Empire, or what? The author sighs vainly for the power, which he rightly allows to the ancient Egyptian, of distinguishing the products of Assyria, Crete, Phoenicia, and Syria (*Kharu*). Reliable knowledge of the city-states of Syria, their social condition, culture, wealth, power, and varying history, is still very small, and M. Montet says nothing to elucidate the subject. To say that the cities of the coast were rich, populous, and productive (p. 179) but that scarcely anything has survived from Dyn. 18 owing to the Egyptian plunderers (did they rob the graves too?) is not very helpful. If M. Montet had substituted 'Phoenician' for 'Syrian' in the title of his book, he would not have needed to suppress more than a few lines.

Nothing is said here of any development of Syrian art, or of a classical age as against one of decadence. Yet it is plain that a period of comparative simplicity was followed by one of excessive decoration, corresponding to the degradation of taste that set in in Egypt under the Ramessides, after lapses in the previous reigns. Syrian products shown in Egyptian tombs of the early New Kingdom are still fairly restrained in style, if more ornate than most Egyptian manufactures, though Fig. 126 is a prophecy of evil to come. From the time of Tuthmosis IV on, however, increasingly ridiculous and complicated show-pieces (*objets d'apparat*) appear, culminating in the atrocities pictured (faithfully?) in Egyptian temples and in the tomb of 'Amiseba' (Imisibe', No. 65). The latter M. Montet seems to regard as the finest productions of Syrian art and as real examples of its culture, not as objects rigged up for sale to those who affected exotic productions, or as attempts at enhancing bullion-value by meretricious showiness. Hence the author's claim 'nul doute que des vases semblables à ceux d'Amiseba n'aient existé dans les temples des Baal et des Baalat' (p. 179). But if objects three-parts definitely foreign in *motif* and symbolism, and even embodying signs of Syrian enslavement to Egypt, formed the furniture of native temples, Syria must have been incapable of an indigenous art worthy of the name. The articles shown by Imisibe' must surely have been of the most tawdry and flimsy construction. One might as well cite the worst examples of *chinoiserie* in England as specimens of English or of Chinese art. But M. Montet has some questionable aesthetic criteria. The source of the decorated crater he finds to be Syria because, whereas in Egypt and Crete it remained simple, in Syria it became an object on which animals and plants could be liberally hung. 'N'est-ce pas la preuve que cette industrie est née dans le pays qui a su lui donner un tel développement?' (p. 170).

The author occasionally shows himself behind the times. He believes that the ornaments shown on the rims of vases were all interior decoration ('c'est la seule solution possible', p. 68). He still sees Syrian slaves and artificers in the bald and bearded old men of Egyptian tombs (pp. 163 f.). He is inclined to

see a cock in the griffin's head of the tombs of Weser and Rekhmirê (and indeed that bird was just known in Egypt in Dyn. 18). But the wattles shown by Hoskins and Prisse seem to be imaginary. He is also unaware of the nature of the ointment-horns ('hampes', p. 48) often shown in the hands of Syrians, affirming that they have not their like in Egypt and do not exist in our museums. There are, in fact, several, and one, now in the Royal Scottish Museum in Edinburgh (Petrie, *Qurneh*, Pl. xxv), supports the author's evidence for their Syrian origin, since, instead of the head of a goddess (Hathor-Astarte) at the point near the spoon at which the horn ends, it has the head of a dove.

For its specific purpose of presenting the Egyptian material in word and picture and commenting on it the book will be found extremely useful, and incidentally there is much sound sense on the relations of the two countries. The best service is done in Chap. V ('Objets trouvés en Égypte') where the author claims for Syria certain Bubastite and other relics which have not always been assigned to that country, chiefly and most safely on the ground that the Syrian manufacturer did not observe the natural proprieties of a scene as did the Egyptian, but mixed his borrowed elements into the design that pleased him most. The argument 'It is not Egyptian enough for Egypt and too Egyptian to be Aegean' assigns an object to Syria as the nation least hampered by national tradition or aesthetic principles. He claims for Syria the griffin (through Mesopotamia), the female sphinx, the horse and chariot, the large ship, the scimitar, the ointment-horn, the shallow vase, the palmette, confronted beasts, galloping animals, the presentation of a scene in space instead of in registers. It is very unlikely that the *hachures* on animals are a Syrian device to suggest curvature, for they merely replace similar markings in Egyptian painting.

As regards the general influence of Syria on Egypt M. Montet has no doubt as to its unhappy character. He fully admits that Egypt began by improving on everything she borrowed and making it her own. But the meretricious objects exported to Egypt tended to deprave her taste; she ended by accepting and imitating objects in the most exaggerated Syrian style, the most useless and bizarre productions. 'En un mot l'art Egyptien a perdu de son sérieux, de sa dignité à partir du moment où il a subi l'influence des étrangers, surtout des Syriens' (p. 182). He admits, too, that Syria was a borrower from the first and is not deceived as to the level its arts attained at their best. 'Nul souci de la réalité ne dicte leur choix. . . . On aime ce qui brille, mais trop souvent l'objet éblouissant est fait d'une mince feuille de métal précieux appliquée sur du bronze ou sur du bois. . . . Cela n'avait pas d'importance puisqu'il ne s'agissait que de décor.' 'On a produit une scène dépourvue de toute signification, mais agréable à voir, comme l'art phénicien a toujours aimé en produire' (pp. 180, 181, 99).

The volume shows some slips in proof-reading. 'Ombrelle' on pp. 66, 77 is surely an error for its half-sister 'ombelle'. On p. 78 there occur 'latiformes' for 'lotiformes'; 'Kenamun' for 'Nebamun' on p. 27, l. 6; 'Schweinfuch' for 'Schweinfurth' on p. 77. Is 'la sphinge', on pp. 110f., really meant to stand? On p. 12 'Tomb 163' should be 'Tomb 162'. Citations of illustrations sometimes err by one unit, more or less (e.g. on pp. 96, 107, 113). An English quotation on p. 147, n. 1, has six mistakes. The index is meagre.

N. DE G. DAVIES.

Haremhab und die Amarnazeit (Teildruck: Haremhab's Laufbahn bis zur Thronbesteigung). By KURT PFLÜGER. Zwickau, F. Ullmann, G.m.b.H., 1936. 8vo. 62 pp.

Only the second of three parts of this doctoral thesis is published, but from a summary of the rest we learn that it offers a solution of two main problems. Why were the names of Tutankhamūn and Eye deleted from the records? And why was Eye made king when Haremhab was already so strong? The reason, in Dr. Pflüger's view, was that the 'heresy' of Amarna was not merely religious, but also political and social, the result of a struggle between classes, which went on throughout the period. The influence of this struggle on Haremhab's career and the part he played in it are brought out in this published part of the work, in which the numerous scenes and inscriptions relating to Haremhab as a private individual are carefully reconsidered. From the titles used at different periods the author concludes that Haremhab was already in a position of extraordinary power under Tutankhamūn before his success in the Asiatic war (there was no Asiatic war in Haremhab's own reign). In view of the difficult political situation it was safer to use the more modest titles, and they do not fully represent the position he held. The reader cannot but feel doubtful whether Egyptian inscriptions and scenes will bear exact evaluation of their smallest details, but Dr. Pflüger's discussion is very careful, and it is to be regretted that he has not been able to publish his other sections.

A. N. DAKIN.

Das altägyptische Bildnis. By HEINRICH SCHÄFER. (Leipziger Ägyptologische Studien, Heft 5.) Glückstadt and Hamburg, J. J. Augustin, 1936. 8vo. 46 pp., 46 pls. RM. 7.20.

Once again Professor Schäfer has given us a book of profound and original thought. It is now nearly twenty years since his *Von ägyptischer Kunst* raised the study of Egyptian art to a new level, and in this new work, brief though it is, we can see the application of the general theory to the narrower field of portraiture. Beginning by pointing out that in the ancient world before classical Greece, portraiture existed in a developed state only in Egypt, Professor Schäfer goes on to show to what extent we can consider Egyptian portraits to be genuine reproductions of the features of the portrayed. He points out that in the early stages of art all sculpture of human beings was to some extent portraiture, because there was no conception of man in general, and every statue was the statue of one particular man even though it might not resemble him to any very marked extent. With the invention of writing this process was simplified, for by the mere writing of the name a statue which bore no true resemblance to the portrayed could readily be identified with him. We have many examples of the working of this theory in the obliteration of a name and the writing of a new one in its place; in these cases it is clear that the important element is the name and that the actual resemblance of the statue to the man whose name it bore was not particularly relevant. But apart from this we have many examples of what must be true portraits; it is, for example, possible to identify a statue of Amenemmes III or Tuthmosis III on facial evidence alone, so well attested are the faces of these two kings. Even in cases where at first sight two statues of a man bear no resemblance to each other, a more careful study will show that they are really very similar; Schäfer quotes as an example of this the classic case of the two statues of Rasnofre, one showing him with a wig and the other with short hair. So unlike did these two statues appear to be that many concluded from this that true portraiture could not be spoken of at this time; but when Engelbach tried the experiment of placing a wig on the short-haired statue it was immediately apparent that they were similar. Schäfer also points out that it was only the face that was thought to need exact representation; the rest of the body could be represented in a purely conventional manner, and so we get a series of type-groups of bodies, differentiated into young men, old men, young women, old women, and so on. The treatment of the faces shows quite clearly that this was due to conscious intention rather than lack of skill.

The plates are excellent. There is one error: the famous ivory statuette of a king from Abydos is reproduced from the plate in *Abydos*, II and not from Pl. 9 of *JEA* 17 as stated in the list of plates. This is unfortunate, as the early photograph taken before the cleaning and repairing by Dr. Plenderleith does not do justice to this very remarkable little object.

P. L. SHINNIE.

Die Erzählung vom Streite des Horus und Seth in Pap. Beatty I als Literaturwerk. By JOACHIM SPIEGEL. (Leipziger Ägyptologische Studien, Heft 9.) Glückstadt, Augustin, 1937. 8vo. 141 pp., 1 pl. RM. 9.—

This book contains many new and interesting ideas, the chief of which is elaborated in Chapter III. The author there attempts to show that the true emphasis of the narrative under discussion is not on 'The Contentings of Horus and Seth', but on the conflict between Rē^c and the Ennead. This conflict is concerned with the assignment of the inheritance of Osiris. The Ennead supports Horus and the principle of hereditary succession, but Rē^c wishes to change the direct succession in favour of his minion Seth. It is claimed that the shifting of emphasis and the preference of Rē^c for Seth, inasmuch as they diverge sharply from the path of the accepted myth, suggest that the real interpretation of the narrative is historical and political. Rē^c is the king of Egypt, the Ennead his council of nome-rulers. The conflict between them is based on the historical experience of the early Middle Kingdom, when the newly strengthened kingship was seeking to oppose hereditary succession in the appointment of nome-rulers, and to set up royal partisans instead. Support for this is found in the realistic description of Seth's position and in the omission of reference to his Asiatic connexions, formed in the Hyksos Period; also in the terms 'office of the ruler' (*iwt hk*), used of the inheritance of Osiris, and 'Council of the Thirty' and 'Corporation' (*knbt*), used of the council of the gods. Other figures in the narrative have a similar historical significance. Osiris in the concluding section stands for the kingdom of Heracleopolis, corresponding to the position given to him in Spell 175 of the Book of the Dead, where the official theology of that kingdom is laid down. His influence in deciding the conflict in a certain direction accords with the probability that the nome-rulers attained their greatest power during the Heracleopolitan régime. Viewed from the time of composition, his kingdom was relatively past; thus it is the kingdom of the dead. Again, the prominent role of Thoth as the champion of hereditary succession

reflects the position of the Hare-nome in the First Intermediate Period and the beginning of the Middle Kingdom. The occurrence of Beb in the Ennead is due to his connexion with Heracleopolis, while his ejection from it echoes that city's decline. Amūn is entirely omitted, and this would be hard to explain if the story were a Ramesside composition of Theban origin. Such an omission, it is claimed, would not be surprising, if the narrative is really what the present theory suggests it to be, namely a Ramesside revision of a work written in the Middle Kingdom.

It may be said at once that this historical interpretation is far from convincing. Contemporary colouring from the period postulated (*e.g.* 'Council of the Thirty') may certainly be present, but its presence need not involve reference to contemporary events. It is very improbable that Horus and Seth, who are still the central figures, now represent merely the respective favourites, in a recent and restricted era, of the nome-rulers and of the king. Such an interpretation implies a facile process of replacing a myth's historical content. It means that the ancient Egyptians were wont to re-use and refurnish their myths as they did their graves. For this is the third historical interpretation suggested for different stages of the story of Horus and Seth. The first stage, as represented in the *Pyramid Texts*, had doubtless a foundation in the predynastic conflict between Upper and Lower Egypt. When the tale was subsequently re-told, as it was in the Kahun Papyrus, the present narrative, and the Horus-myth of Edfu, it is hard to believe that an entirely new historical meaning was given to it. Even in the original stage there was no conscious conservation of history. The Chester Beatty story, as Gardiner remarked, approaches rather the pure *Märchen*: it pieces together many old mythical fragments and adds new ones, its aim being merely to divert.

Spiegel is on firmer ground in his literary analysis and in his explanation of some of the episodes. His suggestion that the episode concerning 'Anti the ferryman is an aetiological myth, explaining his name 'the taloned one' is plausible, since it gives force to the statement that 'the front of his feet was removed'. He is probably right too in saying that the presentation of the Eye by Thoth to Rē̄ symbolizes the delivering of the kingship for reassignment. Although he lavishly uses the epithets 'epic' and 'Homeric' to describe the literary power of the work, he does not agree with Gardiner that the treatment of the gods is 'Homeric', for this, he claims, was circumscribed either by the current myths or by the new historical significance. He likewise defends the narrative against the charge of 'lubricity', maintaining that the homosexual episode is handled with more restraint than in the Kahun Papyrus. He quotes Diodorus to show that even the exhibitionism of Hathor is by no means 'amusing in a Rabelaisian way', but may be connected with a custom by which women uncovered their nakedness before their temple-gods, as an act of petition. If that be so, why does the story say that 'the great god laughed at her'? (The reader is presumably entitled to the same reaction.) Rē̄ laughs, according to Spiegel, because Hathor, a goddess, has made an exaggerated act of self-humiliation which is fitting to mortals only. This austere explanation would be more acceptable if the custom alluded to were better attested, and for an earlier period.

A new translation is appended, and some of the changes are clear improvements, *e.g.* the optative makes better sense in 1, 8. ('May he (Thoth) take the king's ring for Horus'). Spiegel's treatment of 4, 8-9 is somewhat violent both textually and grammatically. The desire to substitute sense for the nonsense of the existing text condones the first type of violence, but not the second. The text states that the Ennead cried out to Rē̄, saying, 'What are these words which thou hast spoken, which are not worthy that they should be heard?' Actually Rē̄, according to the present text, has not uttered a word. An outburst from Horus, however, immediately follows, and it is with this that Spiegel would connect the Ennead's question. He would therefore make two changes, addressing the Ennead's question to Horus and not to Rē̄ (with a corresponding change in the text), and translating the relative form in a future sense. It is very doubtful, however, whether *ih n; mdwt idd'k* can mean anything other than 'What are these words which thou hast said?' since the relative form has past meaning in Late Egyptian (see Erman, *Neuäg. Gr.*, § 823; Gardiner, *JEA* 16, 224, n. 1). Spiegel cites as a parallel P. Beatty I, 10, 12, but the relative form is there partly substantival, and *pr dd-i n'tn* might almost be translated 'my speech to you' (*cf.* Erman, *op. cit.*, § 394, 'ein  wird etwa "seine Rede" sein'), with the temporal reference undetermined. A simple solution of the difficulty, which seems not to have occurred to either Spiegel or Gardiner, is to assume the inadvertent omission of the offending words of Rē̄. The Ennead's question to him then becomes meaningful.

It should be added that there is an error in the opening sentence: this Chester Beatty papyrus is not in the British Museum, like the others, but in Mr. Chester Beatty's private collection.

Atlas zur altaegyptischen Kulturgeschichte von WALTER WRESZINSKI. Teil III: Gräber des Alten Reiches. Bearbeitet von HEINRICH SCHÄFER unter Mitwirkung von HERMANN GRAPOW. Lieferungen 1-4. Leipzig, 1937-8.

In 1909 Walter Wreszinski arrived at Thebes with a young bride, a large camera, and unlimited zeal. The Theban necropolis lay before him, full of pictures, many of which had already been reproduced by copyists. But he considered that a camera could improve on such laboured productions in a few hours. Out of my longer experience I lavished counsels and cautions, until he exclaimed in exasperation 'Do you think that I am a publisher of picture-books?'. Poor Wreszinski! It was just to this that he was doomed by fate and by his own perception what a lively and convincing bioscopic record could be produced of the activities, social customs, and even the emotions of a people so ancient as almost to be primeval, yet already so full of subtlety and sophistication—man in much of his infinite complexity. Thenceforward the *Atlas* took up more and more of his time and energy, until he drew into the vortex of his project his wife and his friends, so that, when early death carried him off in 1935, he had, unknown to himself, contrived not only that his life-work should be continued, but also that the expansion and improvement towards which it had kept moving should still be maintained. Hence Part III, so far as it now lies before us, while showing changes (distinctly for the better), still remains Wreszinski's, and is still served by his wife's devotion. The *Atlas* promises to take a place among the books which facilitate and enliven a return to the ancient world and so entice men towards humanistic thought and practice. And of all peoples the ancient Egyptians offer the warmest welcome to strangers from a distant future.

What then is, in sum, the treasure here exhibited? Words taken from Prof. Schäfer's preface show the quality of his appreciation and become a guarantee of his power to open the eyes of his readers. For him these pictures are 'artistic creations of a high sort which have caught up an exhilarating picture of the life of a shrewd and energetic agricultural people, and to which the pyramids make a fitting background, symbolic of this sturdy State. In them delight in vitality, whether of plant or animal, mingles with solicitude for the claims of death: the huzza of the husbandman alternates with the blow from the tax-gatherer's stick'. If this is not exactly our own political ideal, so much the more quickening.

The interpretation of the scenes having been entrusted to men of such special competence and so well equipped with parallel examples in support of their elucidations, it would scarcely be fitting to detract from the general admiration which the work in its present hands must command by suggesting alternative explanations here and there. As there are points where all will be thankful to find a frequent rock of offence removed from the way, so also there are places where the authors will be followed less readily. It is well known that the philologist's powers are severely tested by the curt and intimate sentences, exhortatory or descriptive, with which these episodes are sprinkled, half decoratively, half in order to gain added vitality, as with the captions of a cinema-film. Prof. Schäfer, too, has often doubted whether he has quite reached what the designer intended to convey to those who should peruse his work. This uncertainty is inevitable, though always a little less than it used to be.

But our admiration of this ancient means of imparting information ought not to be weakened by its inherent limitations. We strive still after the ideal of so educating our peoples that no man, however simple, shall fail to read and learn by reading. Yet here at the beginning of culture a method had already been devised by which the dullest could, without schooling, enjoy a narrative of events, a presentation of scenes, a biographical record, so long as they came fairly near to his own experience. No one of us who takes in hand this series of plates in the light of the very full interpretation given by the editors but will speedily learn to read Ancient Egyptian, not by grammar and rule, but—as soon as he becomes accustomed to its quaint adaptations—pleasantly and easily, by eye and by sympathetic imagination alone.

If a bone had to be thrown to the spirit that always denigrates, it would be in the form of a question whether we are not near, or already at, the point where knowledge of the simpler and recurring features of Egyptian picture-writing may be assumed, and editorial notes be confined to the rarer words and to cases of specially involved syntax in this pictorial script; whether, too, such an economy of explanation might not increasingly be used in this publication also as it advances, so that very valuable observations may be less liable to be lost in stretches of what by that time will be obvious to most. The absolute tyro must not always be catered for; he is less common and less worthy of consideration than he was.

N. DE G. DAVIES.

LIST OF ABBREVIATIONS USED IN REFERENCES TO PERIODICALS, ETC.¹

- Abh. Berlin (München, etc.)* = *Abhandlungen der Preussischen (Bayerischen, etc.) Akademie der Wissenschaften.*
- Acta Or.* = *Acta Orientalia.*
- Aeg.* = *Aegyptus.*
- Aeg. Inschr. Berlin* = *Aegyptische Inschriften aus den . . . Museen zu Berlin.*
- Aeg. Mon. Leiden* = *Leemans, Aegyptische Monumenten van het Nederlandsche Museum van Oudheden te Leiden.*
- AJA* = *American Journal of Archaeology.*
- AJSL* = *American Journal of Semitic Languages and Literatures.*
- Alte Or.* = *Der Alte Orient.*
- Am. Hist. Rev.* = *American Historical Review.*
- Am. Journ. Phil.* = *American Journal of Philology.*
- An. Boll.* = *Analecta Bollandiana.*
- Anc. Egypt* = *Ancient Egypt, continued as Ancient Egypt and the East.*
- Ann. Arch. Anthr.* = *Annals of Archaeology and Anthropology.*
- Ann. Inst. phil. hist. or.* = *Annuaire de l'Institut de philologie et d'histoire orientales.*
- Ann. R. Sc. Pisa* = *Annali della Reale Scuola Normale Superiore di Pisa (Lettere, Storia e Filosofia), Serie II.*
- Ann. Serv.* = *Annales du Service des Antiquités de l'Égypte.*
- Ann. Univ. Roma* = *Annuario della R. Università di Roma.*
- An. Or.* = *Analecta Orientalia.*
- Antiq.* = *Antiquity.*
- 'Αρχ. 'Εφ. = 'Αρχαιολογική 'Εφημερίς.
- Arch. f. Or.* = *Archiv für Orientforschung.*
- Arch. f. Rel.* = *Archiv für Religionswissenschaft.*
- Arch. f. R. u. W.* = *Archiv für Rechts- und Wirtschaftsphilosophie.*
- Arch. Giurid.* = *Archivio Giuridico.*
- Arch. hist. dr. or.* = *Archives d'histoire du droit oriental.*
- Archiv* = *Archiv für Papyrusforschung.*
- Arch. Orient.* = *Archiv Orientalní.*
- Ath. Mitt.* = *Mitteilungen des . . . deutschen archäologischen Instituts, Athenische Abteilung ('Athenische Mitteilungen').*
- BCH* = *Bulletin de correspondance hellénique.*
- Beschr. Leiden* = *Pleyte-Boeser, Beschreibung der ägyptischen Sammlung des niederländischen Reichsmuseums . . . in Leiden.*
- Bibl. Aeg.* = *Bibliotheca Aegyptiaca.*
- Bibl. égyptol.* = *Bibliothèque égyptologique.*
- BGU* = *Ägyptische Urkunden aus den . . . Museen zu Berlin: Griechische Urkunden.*
- Bk. Dead* = *Book of the Dead.*
- BL* = *Preisigke-Bilabel, Berichtigungsliste der griechischen Papyrusurkunden aus Ägypten.*
- BM Quart.* = *British Museum Quarterly.*
- Boll. fil. class.* = *Bollettino di filologia classica.*
- Botti-Peet, Giornale* = *Il Giornale della Necropoli di Tebe.*
- Breasted, Anc. Rec.* = *Ancient Records.*
- Bull. Acad. Sci. URSS* = *Bulletin de l'Académie des Sciences de l'Union des Républiques Soviétiques Socialistes: Classe des Sciences Sociales.*
- Bull. ASOR* = *Bulletin of the American Schools of Oriental Research.*
- Bull. Ass. am. art copte* = *Bulletin de l'Association des amis des églises et de l'art coptes.*
- Bull. Inst. d'Ég.* = *Bulletin de l'Institut d'Égypte.*
- Bull. Inst. fr.* = *Bulletin de l'Institut français d'archéologie orientale.*
- Bull. Ist. dir. rom.* = *Bollettino dell' Istituto di diritto romano.*
- Bull. MFA* = *Bulletin of the Museum of Fine Arts (Boston).*
- Bull. MMA* = *Bulletin of the Metropolitan Museum of Art (New York).*
- Bull. Ryl. Libr.* = *Bulletin of the John Rylands Library.*
- Bull. Soc. arch. d'Alex.* = *Bulletin de la Société royale d'archéologie d'Alexandrie.*
- Bursian* = *Jahresbericht über die Fortschritte der klassischen Altertumswissenschaft.*
- Byz.-neugr. Jahrb.* = *Byzantinisch - neugriechische Jahrbücher.*
- BZ* = *Byzantinische Zeitschrift.*
- CAH* = *Cambridge Ancient History.*
- CCG* = *Cairo Museum, Catalogue Général.*
- Ch. Quart. Rev.* = *Church Quarterly Review.*

¹ The alphabetical arrangement of the abbreviations ignores stops and spaces. The abbreviations used in references to editions of papyri may be found in *CAH*, VII, 889-91; X, 922-4; XI, 927. The form for reference to periodicals is: *JEA* 24, 100, n. 1; for reference to other works in several volumes: *Wb.*, I, 200 (note commas and absence of 'p.').

- Chron. d'Ég.* = *Chronique d'Égypte* (cited by year-numbers).
- CIA* = *Corpus Inscriptionum Atticarum*.
- CIG* = *Corpus Inscriptionum Graecarum*.
- Cl. Journ.* = *Classical Journal*.
- Cl. Phil.* = *Classical Philology*.
- Cl. Quart.* = *Classical Quarterly*.
- Cl. Rev.* = *Classical Review*.
- Cl. Weekly* = *Classical Weekly*.
- CPHerm.* = *Corpus papyrorum Hermopolitanorum*.
- CPR* = Wessely, *Corpus Papyrorum Raineri Archiducis Austriae*.
- C.-R. Ac. Inscr. B.-L.* = *Comptes-Rendus de l'Académie des Inscriptions et Belles-Lettres*.
- Crum, Cop. Dict.* = *A Coptic Dictionary*.
- CSCO* = *Corpus Scriptorum Christianorum Orientalium*.
- Dict. arch. chrét.* = *Dictionnaire d'archéologie chrétienne*.
- DLZ* = *Deutsche Literaturzeitung*.
- EEF* = Egypt Exploration Fund.
- EES* = Egypt Exploration Society.
- Egn. Rel.* = *Egyptian Religion*.
- Erman, Äg. Gr.* = *Ägyptische Grammatik*, 4th edn.
- Erman, Lit.* = *Die Literatur der Aegypter*.
- Erman, Neuäg. Gr.* = *Neuägyptische Grammatik*, 2nd edn.
- Ét. de Pap.* = *Études de Papyrologie*.
- Études* = *Études: revue catholique d'intérêt général*.
- Exp. Times* = *Expository Times*.
- f. (e.g.) p. 81 f. = pp. 81-2.
- Ffls. Inst. fr.* = *Fouilles de l'Institut français*.
- Forsch. u. Fortschr.* = *Forschungen und Fortschritte*.
- Gard., Egn. Gr.* = Gardiner, *Egyptian Grammar*.
- Gardiner-Weigall, Top. Cat.* = *A Topographical Catalogue of the Private Tombs of Thebes*.
- Gauthier, Dict. géog.* = *Dictionnaire des noms géographiques*.
- GGA* = *Göttingische gelehrte Anzeigen*.
- Gr.* = *Grammar, Grammatik, Grammaire*.
- Griffith, Ryl. Pap.* = *Catalogue of the Demotic Papyri in the John Rylands Library, Manchester*.
- Griffith Studies* = *Studies presented to F. Ll. Griffith*.
- Harv. Theol. Rev.* = *Harvard Theological Review*.
- Hierat. Pap. Berlin* = *Hieratische Papyrus aus den . . . Museen zu Berlin*.
- Hierat. Pap. BM: I, II* = *Facsimiles of Egyptian Hieratic Papyri in the British Museum (First Series, Second Series); III* = *Hieratic Papyri in the British Museum (Third Series)*.
- Hierogl. Texts BM* = *Hieroglyphic Texts from Egyptian Stelae, &c., in the British Museum*.
- Hist.* = *History of Egypt*.
- Hist. Z.* = *Historische Zeitschrift*.
- IG* = *Inscriptiones Graecae*.
- IGR* = *Inscriptiones Graecae ad res Romanas pertinentes*.
- Ill. Ldn. News* = *Illustrated London News*.
- Inscr. hiérog.* = *Inscriptions hiéroglyphiques*.
- Jahrb. f. Liturg.* = *Jahrbuch für Liturgiewissenschaft*.
- JAOS* = *Journal of the American Oriental Society*.
- J. as.* = *Journal asiatique*.
- J. Bibl. Lit.* = *Journal of Biblical Literature*.
- JEA* = *Journal of Egyptian Archaeology*.
- JHS* = *Journal of Hellenic Studies*.
- JMEOS* = *Journal of the Manchester Egyptian and Oriental Society*.
- JRAS* = *Journal of the Royal Asiatic Society*.
- J. Rel.* = *Journal of Religion*.
- JRS* = *Journal of Roman Studies*.
- J. Sav.* = *Journal des Savants*.
- JTS* = *Journal of Theological Studies*.
- Kah. Pap.* = Griffith, *Hieratic Papyri from Kahun and Gurob*.
- KVGR* = *Kritische Vierteljahresschrift für Gesetzgebung und Rechtswissenschaft*.
- Lacau, Textes rel.* = *Textes religieux*.
- Leps., Dkm.* = Lepsius, *Denkmäler aus Aegypten und Aethiopien*.
- LQR* = *Law Quarterly Review*.
- M., Chr.* = Mitteis, *Chrestomathie (Grundzüge und Chrestomathie der Papyruskunde, II, 2. Hälfte)*.
- MDOG* = *Mitteilungen der deutschen Orient-Gesellschaft*.
- Mél. Beyrouth* = *Mélanges de l'Université Saint-Joseph, Beyrouth (Liban)*.
- Mél. Maspero* = *Mélanges Maspero (Mém. Inst. fr. 66-8)*.
- Mém. Inst. d'Ég.* = *Mémoires de l'Institut d'Égypte*.
- Mém. Inst. fr.* = *Mémoires publiés par les membres de l'Institut français d'archéologie orientale du Caire*.
- Mém. Miss. fr.* = *Mémoires publiés par les membres de la Mission archéologique française au Caire*.
- Meyer, Gesch. Alt.* = *Geschichte des Altertums*.
- M., Grdz.* = Mitteis, *Grundzüge (Grundzüge und Chrestomathie der Papyruskunde, II, 1. Hälfte)*.
- Mitt. deutsch. Inst. Kairo* = *Mitteilungen des deutschen Instituts für ägyptische Altertumskunde in Kairo*.
- Möller, Hierat. Pal.* = *Hieratische Paläographie*.
- Mon. Piot.* = *Fondation Eugène Piot. Académie des Inscriptions et Belles-lettres. Monuments et mémoires*.
- Münch. Beitr.* = *Münchener Beiträge zur Papyrusforschung und antiken Rechtsgeschichte*.
- MVAG* = *Mitteilungen der vorderasiatisch-ägyptischen Gesellschaft*.
- n. = note.

260 ABBREVIATIONS IN REFERENCES TO PERIODICALS, ETC.

- Nachr. Göttingen* = *Nachrichten von der Gesellschaft der Wissenschaften zu Göttingen. Philologisch-historische Klasse.*
- Nouv. rev. théol.* = *Nouvelle revue théologique.*
- Num. Chron.* = *Numismatic Chronicle.*
- OGIS* = *Dittenberger, Orientis Graeci Inscriptiones Selectae.*
- OLZ* = *Orientalistische Literaturzeitung.*
- Or. Chr.* = *Oriens Christianus.*
- Or. Chr. Anal.* = *Orientalia Christiana Analecta.*
- Or. Chr. Per.* = *Orientalia Christiana Periodica.*
- P.* = *Papyrus.*
- PEQ* = *Palestine Exploration Quarterly, formerly Palestine Exploration Fund's Quarterly Statement.*
- PG* = *Patrologia Graeca.*
- Phil. Woch.* = *Philologische Wochenschrift.*
- Porter-Moss, Top. Bibl.* = *Topographical Bibliography of Ancient Egyptian Hieroglyphic Texts, Reliefs, and Paintings.*
- Proc. Am. Phil. Ass.* = *Proceedings of the American Philological Association.*
- P.-R., Pap. Turin* = *Pleyte-Rossi, Papyrus de Turin.*
- PSBA* = *Proceedings of the Society of Biblical Archaeology.*
- PSI* = *Papiri della Società Italiana.*
- PW* = *Pauly-Wissowa-Kroll-Mittelhaus, Real-Encyclopädie der klassischen Altertumswissenschaft.*
- Pyr.* = *Sethe, Die altaegyptischen Pyramidentexte.*
- Rec. Champ.* = *Recueil d'études égyptologiques dédiées à la mémoire de Jean-François Champollion.*
- Rech. sc. rel.* = *Recherches de science religieuse.*
- Rec. trav.* = *Recueil de travaux relatifs à la philologie et à l'archéologie égyptiennes et assyriennes.*
- Rend. Pont. Acc.* = *Atti della Pontificia Accademia Romana di Archeologia (Serie III): Rendiconti.*
- Rend. R. Ist.* = *Rendiconti del Reale Istituto Lombardo di scienze e lettere.*
- Rev. arch.* = *Revue archéologique.*
- Rev. bibl.* = *Revue biblique.*
- Rev. crit.* = *Revue critique d'histoire et de littérature.*
- Rev. d'égyptol.* = *Revue d'égyptologie.*
- Rev. de myst.* = *Revue de mystique.*
- Rev. de phil.* = *Revue de philologie, de littérature et d'histoire anciennes.*
- Rev. d'hist. eccl.* = *Revue d'histoire ecclésiastique.*
- Rev. Ég. anc.* = *Revue de l'Égypte ancienne.*
- Rev. égyptol.* = *Revue égyptologique.*
- Rev. ét. anc.* = *Revue des études anciennes.*
- Rev. ét. gr.* = *Revue des études grecques.*
- Rev. ét. juives* = *Revue des études juives.*
- Rev. ét. lat.* = *Revue des études latines.*
- Rev. hist.* = *Revue historique.*
- Rev. hist. dr.* = *Revue historique de droit français et étranger.*
- Rev. hist. philos. rel.* = *Revue d'histoire et de philosophie religieuses.*
- Rev. hist. rel.* = *Revue de l'histoire des religions.*
- Rh. Mus.* = *Rheinisches Museum.*
- Riv. di arch. crist.* = *Rivista di archeologia cristiana.*
- Riv. di fil.* = *Rivista di filologia classica.*
- Riv. indo-greco-ital.* = *Rivista indo-greco-italiana.*
- Riv. stor. dir. ital.* = *Rivista di storia del diritto italiano.*
- SB* = *Preisigke-Bilabel, Sammelbuch griechischer Urkunden aus Ägypten.*
- Sethe, Erläut. Lesest.* = *Erläuterungen zu den aegyptischen Lesestücken: Texte des Mittleren Reiches.*
- Sethe, Lesest.* = *Aegyptische Lesestücke zum Gebrauch im akademischen Unterricht: Texte des Mittleren Reiches. 2nd edn.*
- Sethe, Üb. Komm. Pyr.* = *Übersetzung und Kommentar zu den altägyptischen Pyramidentexten.*
- Sitzungsb. Berlin (München, etc.)* = *Sitzungsberichte der Preussischen (Bayerischen, etc.) Akademie der Wissenschaften.*
- Spiegelberg, Dem. Gr.* = *Demotische Grammatik.*
- Spiegelberg, Kopt. Hdwb.* = *Koptisches Handwörterbuch.*
- St. econ.-giurid. Univ. Cagliari* = *Studi economico-giuridichi della R. Università di Cagliari.*
- St. et Doc.* = *Studia et Documenta Historiae et Iuris.*
- St. it. fil. class.* = *Studi italiani di filologia classica.*
- St. Pal.* = *Studien zur Palaeographie und Papyruskunde, ed. C. Wessely.*
- Sup. Gard. Egn. Gr.* = *Supplement to Gardiner's Egyptian Grammar.*
- Symb. Oslo.* = *Symbolae Osloenses.*
- TAPA* = *Transactions of the American Philological Association.*
- Theol. Rev.* = *Theologische Revue.*
- Theol. St. Kr.* = *Theologische Studien und Kritiken.*
- Tijdschrift* = *Tijdschrift voor Rechtsgeschiedenis.*
- Till, Achm.-K. Gr.* = *Achmîmisch-Koptische Grammatik.*
- TLB* = *Theologisches Literaturblatt.*
- TLZ* = *Theologische Literaturzeitung.*
- TSBA* = *Transactions of the Society of Biblical Archaeology.*
- Unters.* = *Untersuchungen zur Geschichte und Altertumskunde Ägyptens, ed. K. Sethe, later H. Kees.*
- UPZ* = *Urkunden der Ptolemäerzeit, ed. U. Wilcken.*
- Urk.* = *Urkunden des ägyptischen Altertums, ed. G. Steindorff.*
- Wb.* = *Erman-Grapow, Wörterbuch der aegyptischen Sprache.*
- W., Chr.* = *Wilcken, Chrestomathie (Grundzüge und Chrestomathie der Papyruskunde, 1, 2. Hälfte).*

ABBREVIATIONS IN REFERENCES TO PERIODICALS, ETC. 261

- W., *Grdz.* = Wilcken, *Grundzüge (Grundzüge und Chrestomathie der Papyruskunde, I, 1. Hälfte).*
- W., *O.* = Wilcken, *Griechische Ostraka aus Aegypten und Nubien.*
- WZKM = *Wiener Zeitschrift für die Kunde des Morgenlandes.*
- ZÄS = *Zeitschrift für ägyptische Sprache und Altertumskunde.*
- ZDMG = *Zeitschrift der deutschen morgenländischen Gesellschaft.*
- Z. f. *kath. Theol.* = *Zeitschrift für katholische Theologie.*
- Z. f. *Kirchengesch.* = *Zeitschrift für Kirchengeschichte.*
- Z. f. *neut. Wiss.* = *Zeitschrift für neutestamentliche Wissenschaft.*
- Z. f. *Numism.* = *Zeitschrift für Numismatik.*
- Z. f. *vergleich. Rechtsw.* = *Zeitschrift für vergleichende Rechtswissenschaft.*
- Z. *Sav.* = *Zeitschrift der Savigny-Stiftung (Romanistische Abteilung).*

LIST OF PLATES

	PAGE
THE BIOGRAPHICAL INSCRIPTIONS OF NEKHEBU IN BOSTON AND CAIRO.	
Plate I. 1. Biographical Inscription of Nekhebu at Boston	<i>Frontispiece</i>
2. Writing-palette of the Chief Steward Amenhotpe.	
Plate II. Biographical Inscription of Nekhebu at Boston	<i>facing p. 2</i>
FURTHER NOTES ON SOME EGYPTIAN FIGURES OF CATS.	
Plate III. Egyptian Figures of Cats	,, 54
Plate IV. Egyptian Figures of Cats	,, 56
THE MANSION OF LIFE AND THE MASTER OF THE KING'S LARGESS.	
Plate V. From the Tomb of Kagemni	,, 86
Plate VI. Funerary Rites from two Fifth Dynasty Tombs	,, 87
THE SO-CALLED OMPHALOS OF NAPATA.	
Plate VII. The So-called Omphalos of Napata	,, 147
EXCAVATIONS AT SESEBI (SUDLA) AND 'AMĀRAH WEST.	
Plate VIII. Plan of the Town	,, 152
Plate IX. 1. The mound (E. 4. 1, 4 and 5) before excavation	,, 154
2. E. 4. 1: first stage.	
3. E. 4. 1 and 5 (E. 4. 4 removed).	
4. E. 4. 5: final stage.	
Plate X. 1. Sesebi (Sudla): Relief of an 'Amarnah princess	,, 156
2. Sesebi (Sudla): Stone lining of a trench.	
3. 'Amārah West: General view of the site from the 'north'.	
4. 'Amārah West: Temple: main gate and niches.	
Plate XI. 1. Entrance to 'northern' side-chapel	,, 156
2. Foundation course of first occupation.	
3. Sandstone stela.	
THE STELA OF THE SCULPTOR SIRĒC.	
Plate XII. The Stela of Sirĕc: front	,, 192
Plate XIII. 1. Stela of Sirĕc: back	,, 194
2. Tomb of Nebetka at Şakḳārah.	
SIR ROBERT MOND, LL.D., F.R.S.	
Plate IV. Sir Robert Mond, LL.D., F.R.S.	,, 208

LIST OF ILLUSTRATIONS IN THE TEXT

	PAGE
SOME REPRESENTATIONS OF TOMBS FROM THE THEBAN NECROPOLIS.	
Figs. 1-24	27-35
THE SO-CALLED OMPHALOS OF NAPATA.	
Fig. 1.	147
Fig. 2.	148
THE HOUSE OF LIFE.	
Fig. 1	158
Fig. 2	169
THREE OLD-KINGDOM TRAVELLERS TO BYBLOS AND PWENET.	
Fig. 1	182
BRIEF COMMUNICATIONS.	
Fig. 1	242

LIST OF REVIEWS AND NOTICES OF PUBLICATIONS

	Reviewed by	PAGE
Greek Ostraca in the University of Michigan Collection. Leiv Amundsen	H. I. Bell	137
Histoire économique et sociale de l'ancienne Égypte. G. Dykmans	Herbert D. Schaedel	138
Royal Sarcophagi of the XVIII Dynasty. William C. Hayes	H. W. Fairman	140
The Excavations of the Egyptian University in the Neolithic Site at Maadi. Oswald Menghin and Mustafa Amer.	Guy Brunton	140
The Rendel Harris Papyri of Woodbrooke College, Birmingham. J. Enoch Powell	H. I. Bell	141
Antaeopolis. Sir Flinders Petrie	G. A. Wainwright	143
Die Fürstengräber von Qāw. H. Steckeweh	G. A. Wainwright	143
Individuum und Gemeinschaft in der ägyptischen Kultur. Walther Wolf	A. N. Dakin	145
Ancient Egyptian Sculpture lent by C. S. Gulbenkian, Esq.	N. de G. Davies	250
The Papyrus Ebers; the Greatest Egyptian Medical Document. Translated by B. Ebbell	Warren R. Dawson	250
Libyer und Ägypter, Beiträge zur Ethnologie und Geschichte libyscher Völker- schaften nach den altägyptischen Quellen. Wilhelm Hölscher	I. E. S. Edwards	251
Die ägyptischen Listen palästinensischer und syrischer Ortsnamen. Anton Jirku	I. E. S. Edwards	252
Les Reliques de l'Art Syrien dans l'Égypte du Nouvel Empire. Pierre Montet. N. de G. Davies	N. de G. Davies	253
Haremhab und die Amarnazeit (Teildruck: Haremhab's Laufbahn bis zur Thronbesteigung). Kurt Pflüger.	A. N. Dakin	254
Das altägyptische Bildnis. Heinrich Schäfer	P. L. Shinnie	255
Die Erzählung vom Streite des Horus und Seth in Pap. Beatty I als Literatur- werk. Joachim Spiegel	J. Gwyn Griffiths	255
Atlas zur altaegyptischen Kulturgeschichte. Walter Wreszinski	N. de G. Davies	257

GENERAL INDEX

A

- 'Abdel 'Azīz Zibīr, Sheikh of the Mahas, 151.
 Achilleus case, 69 f.
achondroplasia, 186 ff.
 Akhenaten, A Later Allusion to, ALAN H. GARDINER, 124.
 Alan Wynn Shorter, 1905–1938, A. M. BLACKMAN, 211–12.
 Alexandria, magistrates of, 65 f.
 'Amārah West, Temple and inscriptions at, 130, 155; first finds at, 247.
 Amenemḥab, tomb of, 39.
 Amenemḥēt, tomb of, 36.
 Amenemōnet, tomb of, 39.
 Amenḥotpe, chief steward, writing-palette of, 9 f.; other monuments of, 10–12; tomb, 16 f.; statues, 18; names and titles, 19 f.; family and career, 20 ff.
 Amenmose, tomb of, 36.
 Amenōpet, tomb of, 36.
 Amenophis III, 18.
 Amenophis IV, builds Sesebi, 153.
 Amenwahsu, autograph of, in tomb, 161.
 AMER, MUSTAFA, and OSWALD MENGHIN, *The Excavations of the Egyptian University in the Neolithic Site at Maadi* (reviewed), 140 f.
 AMUNDSEN, LEIV, *Greek Ostraca in the University of Michigan Collection. Part I: Texts* (reviewed), 137.
 d'Anastasy, J., excavations and collection, 14.
 Apa Jeremias, monks of, 12, 17, 18.
 'Apep, overthrowing, 41 ff.; names of, 52 f.
 Arkell, Mr. A. J., 151.
 Armant, Saharan remains, 130–1; Mond's interest in, 209 f.
 Arrow-heads, coloured or poisoned, 199.
 Aryandes, silver of, 245–6.
 Aswān, 182.
 Augustus and Egyptian civic organisation, 67 f.
 Autograph of owner in tomb, 161.

B

- BARBER, E. A., Bibliography: Graeco-Roman Egypt. Papyrology (1937):
 § 1. Literary Texts, 92–4.
 Bastet with cat, 54 f., 56, 58.
 Bell, Mr. E. David, 151, 247.
 BELL, DR. H. I., short obituary of C. C. Edgar, 133. reviews by, 137, 141–3.
beqa, 181.
 Bes-figure with cat, 56.
 Bibliography: Christian Egypt (1937), DE LACY O'LEARY, 118–23.
 Bibliography: Graeco-Roman Egypt. Papyrology, (1937), various authors, 92–117.

- Bibliography: Pharaonic Egypt (1937), various authors, ed. A. M. BLACKMAN, 213–41.
 Biographical Inscriptions of Nekhebu in Boston and Cairo, The, DOWS DUNHAM, 1–8.
 BLACKMAN, A. M., Alan Wynn Shorter, 1905–1938, 211–12.
 Bibliography: Pharaonic Egypt (1937) (General Editor):
 § 7. Geography and Topography, 228.
 § 11. Palaeography, 230–1.
 § 13. Philology, 231–4.
 § 15. Religion and Magic, 237–41; 84.
 Blemmyes, 247.
 Books, sacred inspiration of, 168; produced in 'House of Life', 176.
 Borchardt, Ludwig, short obituary of, 248.
 Boston Museum, 1, 3, 147.
 Breasted, Professor, 182, 185.
 Bremner-Rhind Papyrus, The—IV, R. O. FAULKNER, 41–53.
 (British Museum), *Ancient Egyptian Sculpture lent by C. S. Gulbenkian, Esq.* (reviewed), 250.
 Bronze coinage under Ptolemies, 202, 203 f.
 Brooklyn Museum of Fine Arts, 151.
 Broome, Miss, 247.
 Brown, Mr. Theodore Burton, awarded essay-prize, 133.
 BRUNTON, GUY, review by, 140–1.
 Bruyère, M., at Dēr-el-Medīnah, 25; at Tell Edfu, 133.
 Buchanan, Mr. L. M., 151.
 Burial, semi-contracted, 243.
 Byblos, 182 f.

C

- Cairo Museum, 1.
 Calverley, Miss, 247.
 Capart, Prof., 151.
 Cats, Egyptian figures of, 54–8; killing snakes, 89. *cessio bonorum*, 70 f.
 Chabrias in Egypt, 201.
 Chellean and Acheulean site at Gilf Kebīr, 131.
 Chinese Parallel to an Egyptian Idiom, A, N. SHIAH, 127–8.
 City government in Roman Egypt, 66 ff.
 Claudius and Alexandria, 66, 67.
 Cleopatra VII, coinage of, 205 f.
 CLÈRE, J. J., *Sur un Nom du Wādi Maghāra (Sinai)*, 125–6.
Sur un Passage de la Stèle Louvre C 1, 242.
 CRUM, DR. W. E., short obituary of Prof. Carl Schmidt, 135.
 Currency of Egypt under the Ptolemies, The, J. G. MILNE, 200–7.
 Cyprus and Egyptian currency, 205.

D

- Dahshūr, Medallion of, 126 f.
 DAKIN, A. N., The Stela of the sculptor Sirē at Oxford, 190-7.
 Bibliography: Pharaonic Egypt (1937):
 § 3. Conservation, 221.
 § 12. Personal Notices, 231.
 reviews by, 145, 254.
 Dances performed by dwarfs or pygmies, 185 f., 189.
 Daressy, M. Georges, death of, 134.
daric, 180, 245 f.
 DAVIES, N. DE G., Bibliography: Pharaonic Egypt (1937).
 § 2. Art and Architecture, 219-21.
 reviews by, 253-4, 257.
 DAVIES, NINA M., Some Representations of Tombs from the Theban Necropolis, 24-40; 247.
 DAWSON, WARREN R., The Writing of the Name *Hike*', 128.
 Pygmies and Dwarfs in Ancient Egypt, 185-9.
 review by, 250-1.
 Diodorus, 177.
 Djeḥo, dwarf, 186 f.
 Drainage system at Sesebi, 152 f.
 Drovetti, Chevalier, collection of, 15 f.
 DUNHAM, DOWS, The Biographical Inscriptions of Nekhebu in Boston and Cairo, 1-8; 147.
 Dwarfs, confused with pygmies, 186 f.; functions, 187; magic, 188.
 DYKMANS, G., *Histoire économique et sociale de l'ancienne Égypte*. 3 v. (reviewed), 138-9.
 Dyson, Pater, 158.

E

- Eaton, Miss Betty, 147, 149.
 EBBELL, B. (trans.), *The Papyrus Ebers; the Greatest Egyptian Medical Document* (reviewed), 250-1.
 Edgar, C. C., short obituary, 133 f.
 Education in Pharaonic Egypt, 159.
 EDWARDS, I. E. S., Bibliography: Pharaonic Egypt (1937):
 § 6. Foreign Relations, 224-8.
 reviews by, 251-3; 151.
 El-Amarna, 'House of Life' at, 160 f.
 Election of the Metropolitan Magistrates in Egypt, The, A. H. M. JONES, 65-72.
 EMERY, WALTER B., Recent Discoveries at Şakḳārah, 243; 199, 209.
 Essay-prize, award of, 133
 Ethiopian king-names, 149.

F

- FAIRMAN, H. W., Short Report on Sesebi Season, 1937-8, 130.
 Preliminary Report on the Excavations at Sesebi (Sudla) and 'Amārah West, Anglo-Egyptian Sudan, 1937-8, 151-6.
 review by, 140; 247.
 Fairman, Mrs., 247.
 Famine Stela of Sehēl, 83, 166 f.

- FAULKNER, R. O., The Bremner-Rhind Papyrus—IV, 41-53.
 Bibliography: Pharaonic Egypt (1937):
 § 8. History, 229.
 § 10. Literature, 230.
 Fell, Mr. Peter, 247.
 First-Dynasty tombs at Şakḳārah, 243.
 Fondation Égyptologique Reine Élisabeth, 249.
 Foundation Deposits at Sesebi, 153.
 Further Notes on some Egyptian Figures of Cats, N. LANGTON, 54-8.

G

- GARDINER, ALAN H., The Mansion of Life and the Master of the King's Largess, 83-91.
 A Later Allusion to Akhenaten, 124.
 The Idiom *it in*, 124-5.
 The House of Life, 157-79.
 The Egyptian for 'in other words', 'in short', 243-4.
 The Reading of the Egyptian word for 'Necropolis', 244-5.
 Garnot, M. Jean Sainte Fare, 8.
 Garstang, Professor, 186, 190.
 Gilf Kebir, Chellean and Acheulean remains at, 131.
 GLANVILLE, S. R. K., Bibliography: Pharaonic Egypt (1937):
 § 4. Demotic Studies, 221-2.
 § 9. Law, 229-30.
 Gold coinage, Ptolemaic, 202, 204; Persian, 245.
 Grabham, Mr. G. W., 151.
 Griffith Institute at Oxford, 248-9.
 Griffith, Prof., 147, 150.
 GRIFFITHS, J. GWYN, review by, 255-6.
 GUNN, BATTISCOMBE, A Summary Writing of the Adverb *nii* in Old Egyptian?, 128-9.

H

- Ḥammāmāt, Ramesses IV's expedition to, 162-3.
 HAYES, WILLIAM C., A Writing-palette of the Chief Steward Amenḥotpe and some Notes on its Owner, 9-24.
Royal Sarcophagi of the XVIII Dynasty (reviewed), 140.
 Herodotus, 199, 200, 245.
Hike', name, writing of, 128.
 Hoards, typical contents, 204, 205.
 HÖLSCHER, WILHELM, *Libyer und Ägypter, Beiträge zur Ethnologie und Geschichte libyscher Völkerschaften nach den Quellen* (reviewed), 251-2.
 Ḥori, tomb of, 38.
 HORNBLOWER, G. D., The 'Golden Horus' Title, 129.
 Horus of *Šnut* in the 'House of Life', 164.
 House of Life, The, ALAN H. GARDINER, 157-79.
 'House of Life' distinguished from Mansion of Life, 83, 90.
 'House of the Morning', 84 f.
 Houses at Sesebi, 152 f.
 Hut-formed chapel, 150.
 Huy, tomb of, 40.

I

- Ikhi and Ihu, Treasurers of the God, 183 f.
 Ipy, son of Amenḥotpe, 23 f.
 Isis as 'Lady of the House of Life', 165, 178.

J

- JIRKU, ANTON, *Die ägyptischen Listen palästinensischer und syrischer Ortsnamen* (reviewed), 252-3.
- JOLOWICZ, H. F., Bibliography: Graeco-Roman Egypt. Papyrology (1937):
§ 6. Law, 105-13.
- JONES, A. H. M., The Election of the Metropolitan Magistrates in Egypt, 65-72.

K

- Kagemni, tomb of, funerary banquet, 86 f.
- Kha'emope, son of Amenwahsu, 161.
- Khentekhtay, names formed from, 191 f.
- Khewefhâr ('Harkhuf'), tomb-inscription of, 185.
- Khnemhotpe, Director of the Kiosk, 182 f.
- Khnemhotpe, dwarf, 186.
- Khnûm as 'lord of the House of Life', 160, 174, 178.
- khoirine*, 180.
- Khons, tomb of, 37.
- Khui, tomb and travels of, 182 ff.
- Koşer, port, 183.

L

- Lange, Dr. H. O., 132.
- LANGTON, N., Further Notes on some Egyptian Figures of Cats, 54-8.
- 'Letters of Agreement', 78 ff.
- Libraries in temples, 177, 179.
- Liverpool University Institute of Archaeology, 209 f.
- LUCAS, A., Poisons in Ancient Egypt, 198-9.
- Early Red Faience, 245.

M

- MACADAM, M. F. L., Bibliography: Pharaonic Egypt (1937).
§ 5. Excavations and Explorations, 222-4.
§ 14. Publications of Texts, 235-7.
- MacDonald, Mr. J. G., 247.
- Mafdet, cat-goddess, 89 f.
- Magic connected with 'House of Life', 164-5, 167.
- Magical significance of dwarfs, 188.
- 'Magicians of Egypt', identical Demotic and Hebrew term, 164 f.; 175.
- Magistrates, election of, in Egypt, 65-72.
- Mansion of Life, The, and the Master of the King's Largess, ALAN H. GARDINER, 83-91.
- Manteuffel, Prof. J., 133.
- Marriage settlements, 74 ff.
- Master of the King's Largess, functions, 88 f.
- Memphis under Eighteenth Dynasty, 23.
- MENGHIN, OSWALD, and MUSTAFA AMER, *The Excavations of the Egyptian University in the Neolithic Site at Maadi* (reviewed), 140 f.
- Merneptah, inscription of, at 'Amārah West, 155.
- Metrology of Egyptian Weights, 180-1.
- MILNE, J. G., Bibliography: Graeco-Roman Egypt. Papyrology (1937):
§ 5. Social Life, Education, Art, Numismatics, and Metrology, 105.
- The Currency of Egypt under the Ptolemies, 200-7.
- The Silver of Aryandes, 245-6.

- Mond, Sir Robert, obituary notice, 208-10; 247.
- MONTET, PIERRE, *Les Reliques de l'art syrien dans l'Égypte du Nouvel Empire* (reviewed), 253-4.
- Moret, Prof. Alexandre, death of, 134.
- Moss, Miss Rosalind, 136, 249.
- Mycenaean sherds at Sesebi, 152.
- MYERS, OLIVER H., notes on season at Armant, 130-1.

N

- Nakhtamûn, tomb of (Dêr el-Medīnah), 39.
- Nakhtamûn, tomb of (Shêkh 'Abd el-Ḳurnah), 37.
- Napata, omphalos of, 147-50.
- Naus Bey, M. Henri, death of, 249
- Nebamûn and Ipuky, tomb of, 36.
- necef*, 180.
- Nedjemger, tomb of, 37.
- Neferhotep, tomb of, 36.
- Neferronpet or Kel, tomb of, 37.
- Nefersekheru, tomb of, 38
- Nefertēm, connected with cat, 55.
- Nekhebu, Biographical Inscriptions of, 1-7; career and titles, 7-8; 128.
- NEWBERRY, PERCY E., The Medallion of Dahshûr, 126-7.
- Three Old-Kingdom Travellers to Byblos and Pwenet, 182-4.
- Sir Robert Mond, 1867-1938, 208-10.
- NIMS, CHARLES F., Notes on University of Michigan Demotic Papyri from Philadelphia, 73-82.
- Nizzoli, Giuseppe di, excavations at Şakḳārah, 12 f., 16.
- Notes on University of Michigan Demotic Papyri from Philadelphia, CHARLES F. NIMS, 73-82.
- Nubian Expedition (1938), 247.

O

- O'LEARY, DE LACY, Bibliography: Christian Egypt, 118-23.
- Osiris, connected with cat, 55 f.; with House of Life, 178.

P

- PALMER, L. R., Bibliography: Graeco-Roman Egypt. Papyrology (1937):
§ 8. Lexicography and Grammar, 114.
- Papyri: Michigan Demotic, 73 ff.; contribution to knowledge of Roman law, 65, 72; mentioning payments in bronze, 204 ff.
- Peach-tree late introduced into Egypt, 198.
- Persian coins in Egypt, 200, 245.
- Pesiûr, tomb of, 37; relation to Ramesside tomb-robberies, 59 f.
- Peteēse of Teudjoi, 165, 166, 176.
- PETRIE, FLINDERS, The Present Position of the Metrology of Egyptian Weights, 180-1.
- Antaeopolis* (reviewed), 143 f.
- peyem*, 180.
- PFLÜGER, KURT, *Haremhab und die Amarnazeit* (reviewed), 254.
- Phoenicia and Egypt under Ptolemies, 202 f.
- 'Place of Truth', general name for Theban necropolis, 163.

- Pliny cited, 198.
 Pohl, Pater A., 158.
 Poisons in Ancient Egypt, A. LUCAS, 198-9.
 Posener, G., 157 f., 160, 169, 178, 179.
 POWELL, J. ENOCH, *The Rendel Harris Papyrus of Woodbrooke College, Birmingham* (reviewed), 141 f.
 Preliminary Report on the Excavations at Sesebi (Sudla) and 'Amārah West, Anglo-Egyptian Sudan, 1937-8, H. W. FAIRMAN, 151-6.
 Present Position of the Metrology of Egyptian Weights, The, FLINDERS PETRIE, 180-1.
 Princess of Bakhtan stela, 167, 170.
 Ptolemies, currency under, 200 ff.
 Ptolemy Epiphanes, early chronology of, 73 f.
 Publications of the Society, 1938, 247.
 Pwenet, 182 f.
 Pwero, Mayor of the West of Thebes, 59 ff.
 Pygmies and Dwarfs in Ancient Egypt, WARREN R. DAWSON, 185-9.
- Q
- qedet*, 180.
- R
- Ramesses II, two new stelae of, 130, 155.
 Ramesses IV, inscriptions of, 162.
 Ra'mose, tomb of (Dēr el-Medīnah), 39.
 Ra'mose, tomb of (Shēkh 'Abd el-Ḳurnah), 36; clearance, 209.
 Ranke, Prof. Hermann, 132.
 Raphael, Mr. O. C., 151.
 Raya, tomb of, 38.
 Rē^c connected with cats, 54, 55.
 Rockefeller, Mr. John D., Jr., 247.
 ROSE, H. J., Bibliography: Graeco-Roman Egypt. Papyrology, 1937.
 § 2. Religion, Magic, Astrology (including texts), 94-7.
 Roy, tomb of, 39.
- S
- Saharan remains at Armant and 'Uwēnāt, 130 f.; at 'Amārah West, 247.
 Şakḳārah, First-Dynasty tombs at, 243; early red tiles, 245.
 Salt, Henry, excavations and collections, 15.
 Sander-Hansen, Dr. C. E., 132
 Saroy, tomb of, 39.
 SCHADEL, HERBERT D., review by, 138-9.
 SCHÄFER, HEINRICH, *Das altägyptische Bildnis* (reviewed), 255.
 Scharff, Dr. Alexander, 131.
 Schmidt, Prof. Carl, death of, 135.
 Schott, Dr. Siegfried, 132.
 'Scribe of the House of Life', 160 ff., 170, 176, 178. *sela*, 181.
 Seneb, dwarf, 186 f.
 Sesebi Excavations, 130, 151-6.
 Seshat and the 'House of Life', 174.
 Seth, 129.
 SHIAH, N., A Chinese Parallel to an Egyptian Idiom, 127-8.
 SHINNIE, P. L., review by, 255.
- Shorter, Alan Wynn, death of, 135; obituary notice, 211-12.
 Silver standard under Ptolemies, 202 ff., 206, 245.
 Sir Robert Mond, LL.D., F.R.S., 1867-1938, PERCY E. NEWBERRY, 208-10.
 Sir Robert Mond Expedition at Armant, 130 f.
 Sirē^c, sculptor, stela of, 190 f.
 SKEAT, T. C., Bibliography: Graeco-Roman Egypt. Papyrology (1937):
 § 3. Publications of non-literary texts, 97-102.
 § 7. Palaeography and Diplomatic, 113.
 § 9. General Works, Bibliography, General Notes on Papyrus Texts, 114-16.
 § 10. Miscellaneous, Excavations, Personal, 116-17.
 So-called Omphalos of Napata, The, GEORG STEINDORFF, 147-50.
 Some Representations of Tombs from the Theban Necropolis, NINA M. DAVIES, 24-40.
 SPIEGEL, JOACHIM, *Die Erzählung vom Streite des Horus und Seth in Pap. Beatty I als Literaturwerk* (reviewed), 255-6.
 Starkey, J. L., career and death of, 134.
stater, 180.
 Statues of Amenhotpe, chief steward, 18 f.
 STECKEWEH, H., *Die Fürstengräber von Qaw* (reviewed), 143 f.
 STEINDORFF, GEORG, The so-called Omphalos of Napata, 147-50.
 short obituary of Borchardt, 248.
 Stela from near El-Reḳāḳnah, 190 ff.
 Stricker, 164 f.
 Sur un Nom du Wādi Maghāra (Sinai), J. J. CLÈRE, 125-6.
 Sur un Passage de la Stèle Louvre C 1, J. J. CLÈRE, 242.
- T
- Tachos, coin of, 201.
 Taxation in Egypt, Roman and 19th-century, 63 f.
 Tell Edfu, Franco-Polish excavations at, 133.
 Temple at Sesebi, 154, at 'Amārah West, 154 f.
 Tetradrachms, Athenian and Alexandrine, 201 f.; Cypriote, 205.
 Theban Necropolis, tomb-representations from, 24-40; Mond's work in, 208 f.
 Thoth and the 'House of Life', 162, 172, 173.
 Thoughts on Three Recent Articles, G. A. WAINWRIGHT, 59-64.
 Three Old-Kingdom Travellers to Byblos and Pwenet, PERCY E. NEWBERRY, 182-4.
 Titles and epithets, of Amenhotpe, 19 f.; title 'rbt, 78.
 Tjetji, Treasurer of the God, inscriptions of, 182 f.
 Tjonüfer, tomb of, 38.
 Tjoy, tomb of, 38.
 Tomb-paintings, damage to, at Thebes, 132.
 Tomb-plans, 144, 243.
 Tomb-representations from the Theban Necropolis, 24-40.
 Tomb-robberies, Ramesside, modern parallels to procedure, 59 ff.
 Tombs, individual, described, 16 ff., 18, 86 f.; represented, in Theban Necropolis, 24-40; First-Dynasty, at Şakḳārah, 243.

Tulli, Professor, 158.
 TURNER, E. G., Bibliography: Graeco-Roman Egypt. Papyrology (1937):
 § 4. Political History, Biography, Administration, Topography, and Chronology, 102-5.

U

Udjeharresnet, inscription on statue of, 157 ff.
 Ulpian, 68.
 'Uwēnāt, Saharan remains at, 131.

W

Wādi Hammāmāt, graffiti in, 183 f.
 Wādi Maghāra (Sinai), 125 f.

WAINWRIGHT, G. A., Thoughts on Three Recent Articles, 59-64.
 Bibliography: Pharaonic Egypt (1937):
 § 1. Archaeology, 213-19.
 reviews by, 143-5.
 Walker, Mr. A. C., 151.
 Water-pouring in funerary rites, 90.
 Weights, Egyptian, 180-1, modern parallels to ancient confusion, 62 f.
 WOLF, WALTHER, *Individuum und Gemeinschaft in der ägyptischen Kultur* (reviewed), 145.
 WRZESINSKI, WALTER, *Atlas zur altaegyptischen Kulturgeschichte, Teil III* (reviewed), 257.
 Writing of adverb *nīl*, 128; of name *Hike'*, 128, Late-Egyptian, 244.
 Writing-palette of the Chief Steward Amenhotpe, A, and some Notes on its Owner, WILLIAM C. HAYES, 9-24.

INDEX OF WORDS, ETC., DISCUSSED

A. EGYPTIAN

I. WORDS AND PHRASES













- šwt*, 'markings' of a sacred ram (Gardiner), 170, n. 4.
šhw, 'efficiency', 'ability' (Gardiner), 157, n. 5.
 'In-(*ī*)t-f, n. pr., 'He who brings his father' (Dakin), 192, n. 13.
iry *nty*, 'myrrh-keeper', *i.e.* keeper of drugs (Gardiner), 178.
*iry*t written $\overline{\text{C}}$ (Dunham), 2, n. 5.
ik, see *k*.
it *in*, 'move to and fro', 'waver', etc., of physical or psychological movement (Gardiner), 124 f.
cbw: *hr cbw-in*, 'because of (?) your impurity (?)' (Dunham), 6, n. 6.
cm: also *cm* below?, 'devourer (?)', perhaps from *cm* 'to swallow' (Faulkner), 53.
cnh *n tt hkr*, recipient from Royal Table (Gardiner), 88, n. 5.
rbt (dem.), 'trustee' who held record of a transaction (Nims), 78 ff.; doubtful whether connected etymologically with $\Delta P H \dot{H}$, 82, n. 2.
qd(?)mr dw *Hr hnti pt*, 'administrator of (the vineyard) Praising-Horus-at-the-front-of-heaven' (Gardiner), 85.
Wzy, 'The evil-minded (?)' (Faulkner), 53.
wbbw, utterly obscure word (Faulkner), 48.
wcb Shmt, 'priest of Sakhmet', a doctor or magician of sorts (Gardiner), 173, n. 4.
wrtw n tt hkr, officer connected with Royal Table in M.K. (Gardiner), 88, n. 5; 179.
wp . . . (?), 'first day of month' (Dunham), 5, n. 9.
wsh, of one whose influence pervades (Faulkner), 47.
wqb, technical term in connexion with offerings, 'diversion' (Gardiner), 86 f.
 [*bin dpt rf*], 'taste of whose mouth is bad', referring to smell of mother's milk (Shiah), 127.
bhnw may be identical with *bhnt*, 'knife' (Faulkner), 50.
pr, 'to be primaeval (?)', related to *prw* (Faulkner), 46 f.
prutyw, 'substance (?)', perhaps same as $\text{X} \circ$ (Faulkner), 49.
pr-cnḥ, 'House of Life', place where medical and religious books were written, not a training-college or University (Gardiner), 157 ff.
pr-cnḥ-irw, connected with ritual revival of a god (Gardiner), 175.
Pr-cnḥt, a town between Sohāg and Kōm Ishgāw (Gardiner), 175.
pr-mḏst, 'library' of a temple (Gardiner), 177, with n. 2.
pr dwst, 'House of the Morning', where king's toilet was performed, not necessarily only in temple (Gardiner), 84.
Pkr, M.-K. writing without -r (Dakin), 191, n. 5.
fkty, kind of priest, identified with Shu (Gardiner), 169, n. 1.
m-ht, 'in the service of' (Dunham), 4, n. 11.
m-s in dem., 'pertaining to' (Nims), 78.
mwt, perhaps 'rule', 'measuring-rod' (Dunham), 4, n. 14.
Mjfdt probably cat-goddess, not mongoose (Gardiner), 89 f.
Mr-w(y)-s(y)? n. pr., 'How beloved is she!' (?) (Dakin), 192, n. 17.
mry w-in, perhaps 'is . . . desirable to you?' (Dunham), 5, n. 11, 6, n. 12.
mk, 'protect', written with same dets. as *mkt*, 'place', in word-play (Faulkner), 51.
mt(r)t, *mt(y)t*, 'témoignage' en moyen-ég. (Clère), 242.
mtw dem. conjunctive used independently as future, implying obligation (Nims), 77 f.
mdw m, 'speak about' (Dunham), 5, n. 2.













- Nt-sbdw-Srt-Wp-wrwt*, probably double name (Dakin), 193, n. 8.
- nll* perhaps simply 𓏏 in O.-Egn. summary writing (Gunn), 128 f.
- n^{cc} im-s*, perhaps of soothing (Faulkner), 48.
- Nwtnw* (also *Nwt*, etc.), 'Hunting-Country', unusual sign in writing (Newberry), 183, n. 3.
- n^bw^w-^{cn}h*, 'gold-amulets (?)', true nature of objects unknown (Dunham), 2, n. 9.
- nml*, *nmw*, 'dwarf' (Dawson), 185.
- Nrwtt*, corrupt writing of (Faulkner), 50.
- nhs*, 'danger (?)' (Faulkner), 51.
- nkm*, originally 'to be bald', later 'to suffer' (Faulkner), 50.
- n^{dr}*, with det. of man with axe standing on piece of wood (Dunham), 2, n. 7.
- r*, omitted in O. Egn. before infin. or *dr* (Dunham), 2, n. 14.
- r-ib*, specialized meaning 'cardia' finds no support (Dawson), 251.
- rh-ht*, writing with 𓏏 (Gardiner), 170, n. 2; means only 'learned', without religious colouring, 176, n. 1.
- hs*, 'lay out (?)' (Dunham), 2, n. 13.
- hwt-^{cn}h*, 'Mansion of Life', place where Pharaoh or god lived, not identical with *pr-^{cn}h* (Gardiner), 83 ff.
- Hpw^t*, strange writing for n. pr. *Htpw* (Dakin), 194, n. 6.
- hnty*, 'slaughterer' connected with 'House of Life' ? (Gardiner), 169.
- hr*: *hr-k r-s*, 'thou art bound in that direction' (Faulkner), 50.
- Hr imy Šnw^t*, 'Horus in Šnw^t (?)' (Gardiner), 164.
- hri w^{db}* (*m hwt-^{cn}h*), 'Master of the (king's) Largess (in the Mansion of Life)' (Gardiner), 83 ff.
- hri-tp*, for *hri-hbt hri-tp*, 'chief lector-priest', and equivalents in demotic, Assyrian, and Hebrew (Gardiner), 164 f.
- Hks*, the god 'Magic', curious variations in the writing of the name (Dawson), 128.
- h^{tp}* (*r^{di}(w) nisw^t*), 'an offering given by the King', not a wish (Gardiner), 89, n. 1.
- Htpwy*, n. pr. fem., 'The Two Peaceful Ones (?)', perhaps with ref. to fight of Horus and Seth (Wainwright), 144.
- hryt*, with various det., probably 'executioners' (Faulkner), 49.
- hfy* = *hf*, late var. of *fh*, with sense of 'ruin', 'destruction' (Faulkner), 53.
- hftw*, 'before', with temporal meaning ? (Dunham), 2, n. 12.
- hnm m*, lit. 'be presented with', of something bad (Faulkner), 49.
- hnty* with det. 𓏏 in M.K. (Dakin), 192, n. 5.
- Hnty-h^{ty}*, evidence that second element is a *nisbe* (Gunn), 191, n. 9.
- hrp nstⁱ* (*m hwt-^{cn}h*), 'controller of the two seats (in the Mansion of Life)' (Gardiner), 85.
- hrp hst^s km*, 'Controller of the black wine-jar' (Gardiner), 85.
- htyw (m)fkst*, 'Terrasses de la Turquoise', nom du Wâdi Maghâra (Clère), 125 f.
- Hty*, n. pr., 'The paunchy (?)' (Gunn), 191, n. 12.
- hry-c*, 'apprentice' (Gardiner), 159.
- hrt-ntr*, word for 'necropolis' so to be read (Gardiner), 244 f.
- s* for *sn* in O. Egn. (Dunham), 6, n. 15.
- S-n-mdw*, n. pr., 'The man of the staff' (Gunn), 194, n. 2.
- st mst*, 'Place of Truth', a general name of the Theban necropolis (Gardiner), 163.
- š:* (a) writing of *šw*; (b) for *šd*, by false transcr. from hieratic (Dunham), 4, n. 10, 6, n. 1.
- Sⁱ-Šht-Hr*, n. pr., 'Son of Sekhathor' (Dakin), 193, n. 10.
- Srt-rrrw*, n. pr., probably for *Srt-rrw* (Dakin), 193, n. 3.
- srw* with a nuance of captivity (Faulkner), 48.
- sb* 'dignitary', does not imply elevated rank (Newberry), 184, n. 2.
- sb iry mdst*, officer who kept records (of an expedition) (Newberry), 184.
- st*, exact nature of this action not clear (Gunn), 90 f.
- st^{cn}h* in dem. marriage settlements, 'revenue-producing property', 'endowment' (Nims), 75 f.
- šw*, see *š*.
- sb*, with various fish-dets. = (a) writing of *sbi* [*hr*] 'intercede [for] (?)', (b) 'in hostility (?)' (Dunham), 3, 4, 5, n. 14; 6, nn. 5, 7; cf. Editor's n., p. 8.
- shw* with apparently reflexive object, 'excuse oneself (?)' (Gardiner), 244, n. 1.
- sh^m*, transitive use with dependent pron. (Faulkner), 50.
- sh^m trwy*, title of Wepwawet (Dakin), 192, n. 4.
- šš*, 'mode of writing', not 'writings' or 'books' (Gardiner), 172.
- šš n wy*, in dem., 'cession' (Nims), 78, n. 3.
- šš n pr-^{cn}h*, in late period used of hieroglyphic writing and presumably including hieratic (Gardiner), 176.
- stf*, 'rage' of waters rising up in storm (Faulkner), 51.
- šd*, see *š*.
- šdm-n-f* in fut. perf. use (Dunham), 6, n. 1.
- šdryt* (*nt Šn-Hr*), bivouac after battle with Osiris's enemies (?) (Dakin), 191, n. 6.
- šc*, 'palette (?)' (Dunham), 4, n. 13.
- šc n (?) pr-^{cn}h*, in dem., perhaps simply a hieroglyphic book (Gardiner), 175.
- šct*, geht vielleicht auf ein wirkliches Zahlungsmittel zurück (Schaedel), 139.
- šbt*, 'meat-portion (?)' (Faulkner), 50.
- špt*, det. with 𓏏 (= 𓏏 ?) (Dunham), 3.
- Šn-Hr*, of significance in Osiris-legend at Abydos (Dakin), 191, n. 6.
- kt*, verb perhaps to be connected with *kri*, in impv. = 'depart!' (Faulkner), 49.
- kr* (earlier *ky*): *m kr dd*, 'in other words', 'in short' (Gardiner), 243 f.
- krwti*, 'workman', in O.K. (Dunham), 2, n. 1.
- Knmty*, 'The dark one (?)' (Faulkner), 53.
- ts* (also *tis* and *tis*), 'plant firmly', original of Cop. $\tau\omega\sigma$ (Gunn), 125, n. 3.
- tt*, variously written, 'staff', derived from *tt*, 'board', 'table' (Gardiner), 157, n. 3, 170 f., 179.

ttyw, 'men of the staff', masc. plur. of derivative from *tt* (Gardiner), 170 f.
tr in plural, with several dets., of the young of serpents (Faulkner), 50.
di:n (dem.), perf., yet referring to document in which it appears (Nims), 79, n. 1.

dbdb, 'squirt out (?)' and similarly spelt verbs (Faulkner), 49 f.
d(s)ng, 'pygmy' (Dawson), 185.
db: sšr r, 'to stick (?) arrows in' (Faulkner), 50.
db: hr dbw:i, 'through my action' (Dunham), 5, n. 4.
dbw, 'reversion' of offerings (Gardiner), 88.

II. SIGNS AND GROUPS¹

 derived from iconographic presentation of Isis suckling Horus, finger touching lips expressing desire for milk (Shiah), 127 f.
 read *iryt* (Dunham), 2, n. 5.
 obscure group, for 'his chamber'? (Faulkner), 49.
 reading *b(s)h* in *bhnw* (Faulkner), 50.
 'first day of month' perhaps original of late  (Dunham), 5, n. 9.
 used both with *id* and *idn* (Gunn), 8.
 'Horus and the Ombite (Seth)' (Hornblower), 129.
 in late writings of *rh-ht* (Gardiner), 170, n. 2.
 perhaps has value *sb* in *sbn* (Gunn), 8.
 'ill (?)' (Faulkner), 51.
 probably a writing of *Nrwtt* (Faulkner), 50.

 'confined (?)' (Faulkner), 48.
 'knives' (Faulkner), 50.
 'rise up', assuming confusion with  (Faulkner), 50.
 'enemies' (Faulkner), 53.
 as writing of *mdjt*, 'book', perhaps only late and secondary (Gardiner), 171.
 and , writings of *tt* and *ttyw*, perhaps due to confusion of  and  in hieratic (Gardiner), 170 f.
| instances in O.K. not determining pictographic character of sign it follows (Gardiner), 84, n. 3.
 word of uncertain reading and meaning, 'pigment (?)' (Faulkner), 49.
 det. of *spt*, =  ? (Dunham), 3.

B. COPTIC

αρηή, 'pledge', doubtful whether dem. *ῥβτ* can be connected etymologically with it (Nims), 82, n. 2.

τωσ, 'become, be hard', derived from Egn. *ts* (Gunn), 125, n. 3.

C. GREEK

ἀρχιπρότανις, additional title of head of board of metropolitan magistrates (Jones), 66.
 γυμνασίου, οἱ ἀπό, privileges of (Jones), 67.
 δῆμος, in Egn. cities (Jones), 67.
 ἐξηγητής, head of Egn. metropolitan magistrates (Jones), 66.
 ἐφηβία, avenue to possession of full Alexandrian citizenship (Jones), 67.
 κίνδυνος, involved in nomination to magistracy (Jones), 70.
 μητροπόλεως, οἱ ἀπό, privileges of (Jones), 67.
 μηχανία, more definite than 'equipment'; μηχανίον presumably the *sākyah* (Bell), 143.

πολι(τῶν) δημόσιος, referring to donkeys supplied by metropolites for δρόμος δημόσιος? (Bell), 137.
 προβάλλεσθαι, technical term (in appointing magistrates) of great significance (Jones), 69.
 προβολή, of metropolitan magistrates in council, alone survived in 3rd cent. (Jones), 71.
 πρυτάνεις, proper designation of metropolitan magistrates (Jones), 66.
 φυλαί, persistence and functions in Eastern cities (Jones), 71 f.
phylacrisia, new term (Bell), 142.
 χειροτονεῖν ἐαυτόν, technical term obviously misused (Jones), 69.

¹ The signs (or, in the case of groups, the first signs) are arranged in the order of the sign-list in Gard., *Egn. Gr.*